

Practices of urban inclusion

From Design to Implementation

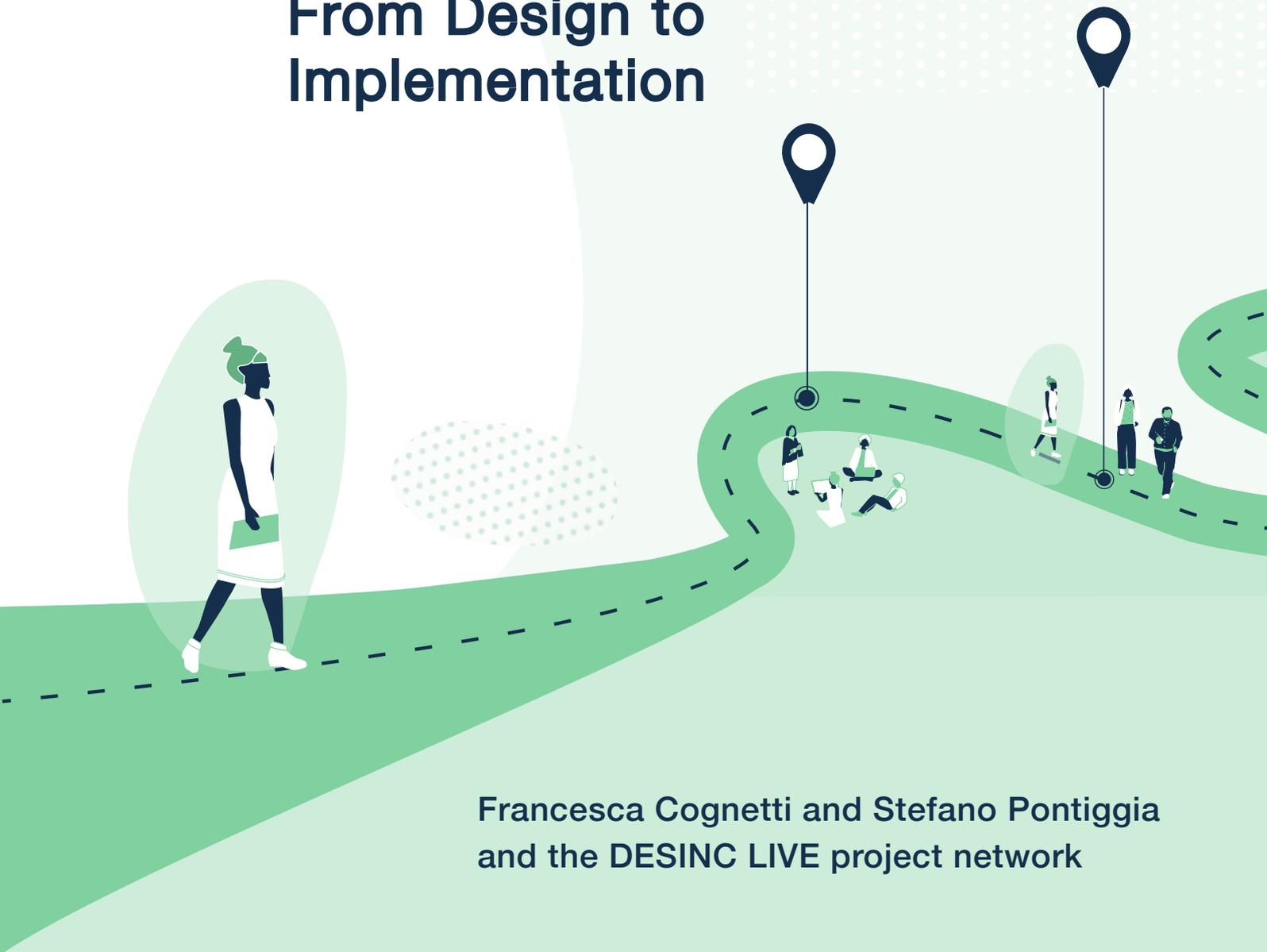

Francesca Cognetti and Stefano Pontiggia
and the DESINC LIVE project network

About this report

This report was produced by Politecnico di Milano with input from all the institutions that are part of the project: **DESINC LIVE**.

Authors: Francesca Cognetti and Stefano Pontiggia.

Contributors: Markus Bader, Giorgio Baracco, Lucia Caistor-Arendar, Ida Castelnuovo, Viviana d’Auria, Beatrice De Carli, Vera Fritsche, Tahmineh Hooshyar Emami, Rowan Mackay, Katharina Rohde, Anton Schünemann, Angelica Villa.

Design: Lucia Caistor-Arendar

Published by: London Metropolitan University (2022)
ISBN: 978-1-907675-44-7

Suggested citation: Francesca Cognetti and Stefano Pontiggia, Practices of Urban Inclusion: From Design to Implementation (London: London Metropolitan University, 2022).

For further information visit: www.desinclive.eu

DESINC LIVE – Designing and Learning in the Context of Migration is a project funded by European Commission under the Erasmus+ programme (2019-2022).

Project partners: Architecture Sans Frontières–UK, KU Leuven, London Metropolitan University (2020-2022), Politecnico di Milano, Refugees Welcome Italia, Schlesische 27, Universität der Künste Berlin, University of Sheffield (2019-2020).



Contents

Introduction	2
Course summary	10
Course structure	11
Online activities	14
Local unit activities	19
Live Workshops 2021	22
Berlin Live Workshop	23
Milan Live Workshop	34
Project partners	48
Appendixes	53

Introduction

This report emerges out of a collaborative EU funded project titled: DESINC LIVE – Designing and Learning in the Context of Migration (desinclive.eu). Since September 2019, the project has brought together a group of fourteen educators, researchers and practitioners from four Higher Education Institutions (HEIs) and three Civil Society Organisations (CSOs) based in four European countries to jointly design, test and evaluate an experimental educational offer titled: Practices of Urban Inclusion.

The report describes the activities involved in running Practices of Urban Inclusion for the first time.. The course represents the experimental phase of DESINC LIVE and has been designed around a blended learning approach, combining online educational opportunities with place-based methods. Between May and October 2021, online lectures and seminars, local meetings, independent activities, and two live workshops have been designed and implemented to stimulate new ways of thinking about the nexus between migration and urban contexts among a community of 29 learners selected by the institutions involved in the project.

The course has numerous innovative aspects: the use of different teaching methods other than traditional lecturing; the disruption, or at least the levelling, of the academic hierarchy in favour of a more horizontal learning process; the interdisciplinarity of the community of learners and teachers; the importance given to self-reflexivity and individual positioning in the process; and the openness to different experts and knowledge producers (e.g. practitioners, activists, artists, and inhabitants).

DESINC LIVE is now entering its final stage, where the project partners will assess the validity and feasibility of the course in light of a potential replication and consolidation as an education proposal within and outside academia.

This report describes the core components of the course: its overall structure and learning aims; its blended nature; its two live workshops; and the outputs resulting from it. The goal is to highlight the complexity, richness, and innovative character of the proposal.

About DESINC LIVE

The DESINC LIVE project is set within the European context and centres on migration as a critical component of urbanisation, and an essential lens for understanding how dynamics of power, oppression and emancipation relate to city-making.

The project is specifically concerned with knowledge and learning. What knowledge about cities and migration informs the definition of urban policies and plans? What knowledge underpins the design and material construction of buildings and places? Whose perspectives are taken into consideration in the making of the city, and why? And what can social work and activism gain from a greater understanding of how the built environment works?

The project has addressed these questions by developing this experimental learning programme that links together professional and experiential knowledge, art practice and urban policy, theory, and action. The educational programme aims to provide current and future practitioners with the conceptual and practical tools that will enable them to develop new ways of fostering inclusion in urban space.



Figure 1: Team work in Berlin. Photo Luisa Durrer, S27 - Art and Education.

Course summary

This course asks how we can plan, build and put into practice cities that promote inclusion. The course centres around the lived experiences of migration, displacement and exile as key perspectives to understanding how urban spaces can produce or challenge exclusion. In doing so, the course explores how urban planning, architecture and spatial practice can contribute to making cities of care and conviviality, where more people feel welcome in more spaces.

The course invites participants to confront the pressing social, political and ethical concerns that relate to migration and movement in European cities. Learners will critically reflect upon their own forms of urban practice, and develop new ways of fostering inclusion in urban space.

6



Months

29



Learners

4 Universities

3 CSOs

2 Live workshops



4 Countries



Learner journey map

This user journey map summarises the course's experience from the perspective of those involved. How will the journey start? How will it end? What points of contact will happen for learners, where, and how?

Here we have visualised how the journey will develop for Ana during the first iteration of the course in 2021.

Key



Set group activity



Ongoing activities



Key moments of contact

Participant: Ana



Learning methods



Situating



Engaging



Mapping

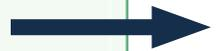
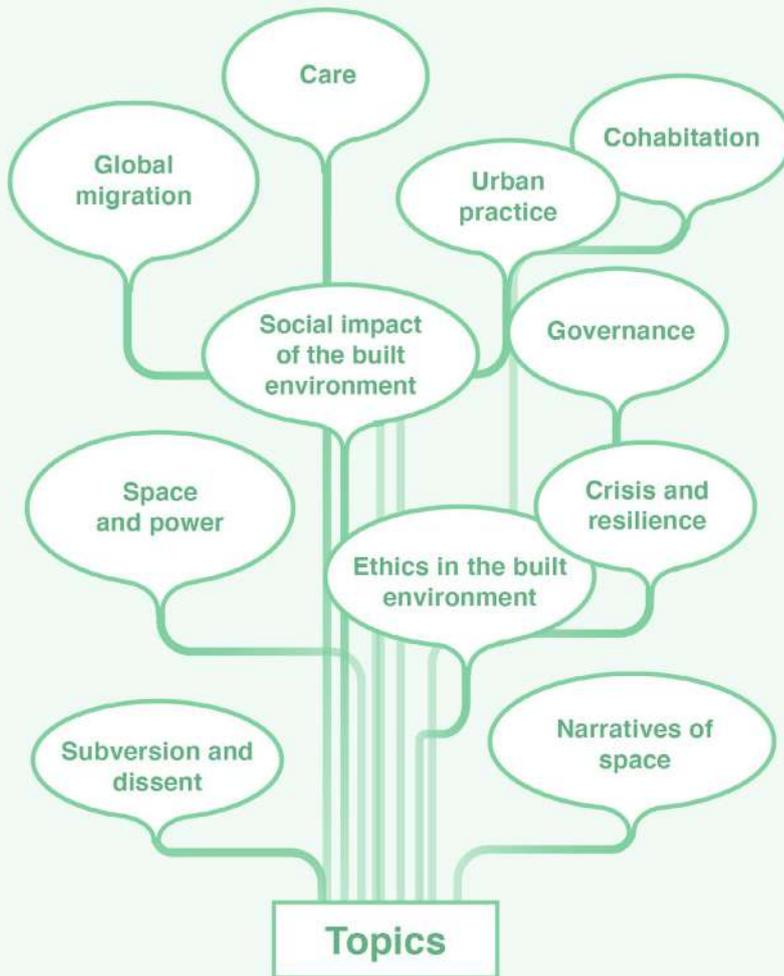

Kick-off meeting



2021





Mapping



Envisioning



Making



Communicating



Reflecting



Berlin Live Workshop

The Berlin workshop took place in the district of Marzahn, located on the outskirts of the city. Here, a refugee camp initially set up as an emergency shelter is now one of the largest accommodations for refugees in Berlin.

HOSTS:
Universität der Künste Berlin and Schlesische27.

18 learners

Open Sessions

Mid-point meeting

Personal reflections

Open Knowledge Platform

The Open Knowledge Platform supports the participants through their journey. It contains a Collective Archive, enabling in-depth engagement with the issues explored in the live workshops.



Milan Live Workshop

The Milan workshop was set in the district of San Siro. San Siro is one of the largest public housing estates in Milan and a large percentage of its population has a migratory background.

HOSTS:
Politecnico di Milano and Refugees Welcome Italia.

18 learners



Closing meeting

September

Peer to peer support



Local clusters



London



Berlin



Brussels



Milan

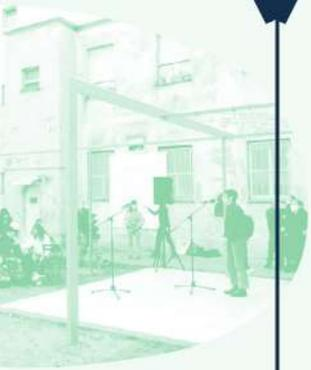

Course structure

The course aimed to fulfil five specific learning outcomes:

- 01** Developing critical collaboration and communication skills
- 02** Mapping complex urban territories and producing multidimensional analyses of places based on a combination of hands-on experience, theory-informed practice, and critical reflection
- 03** Envisioning different forms of urban practice and reflecting on their value in relation to a wider set of possibilities for architecture, urban design, urban planning, social policy and social work
- 04** Experimenting and criticising context-responsive methods and tools for transforming urban spaces in ways that are equitable and inclusive of the diverse needs and aspirations of all urban dwellers
- 05** Developing awareness and capacity to reflect upon their own position within society as urban dwellers, learners and (future) practitioners



Figure 2: Team work in Berlin. Photo Luisa Durrer, S27 - Art and Education.

Participants

The selection process

This course aimed to bring together a wide range of learners across Europe from different backgrounds, focusing on people who have a personal and/or professional experience of transnational migration, and/or have a background in social work, social policy, urban geography, urban planning, urban design, architecture, visual arts, public performance and other creative disciplines engaging with urban space. We wanted to create an international community of practitioners that span these fields and are willing to integrate different forms of knowledge into their future practice.

To create this community, HEIs launched a call including the [course prospectus](#).

- 40+ candidatures received by HEIs.
- Evaluation based on CVs, motivation letters and individual interviews.
- Criteria for selection: past work/education experiences; affinity with the topics of migration and urban inclusion; personal motivation; skills; ethnic/cultural/language diversity.

CSOs also launched the call among their recipients/learners by relying on the course prospectus.

- 20+ candidatures received by CSOs
- Evaluation based on CVs, motivation letters and individual interviews.
- Criteria for selection: personal motivation; personal experience of migration; consistency of the educational/professional path with the contents of the course; availability to attend appointments in presence and remotely; ; administrative status and capacity to travel.

The learning community

Following the selection process, the cohort attending the course consisted of 29 learners from seven institutions in four different countries, largely but not entirely coming from the fields of architecture and urban planning. The community showed great diversity in terms of both educational/professional as well as ethnic and cultural background.

How would you describe your educational background?

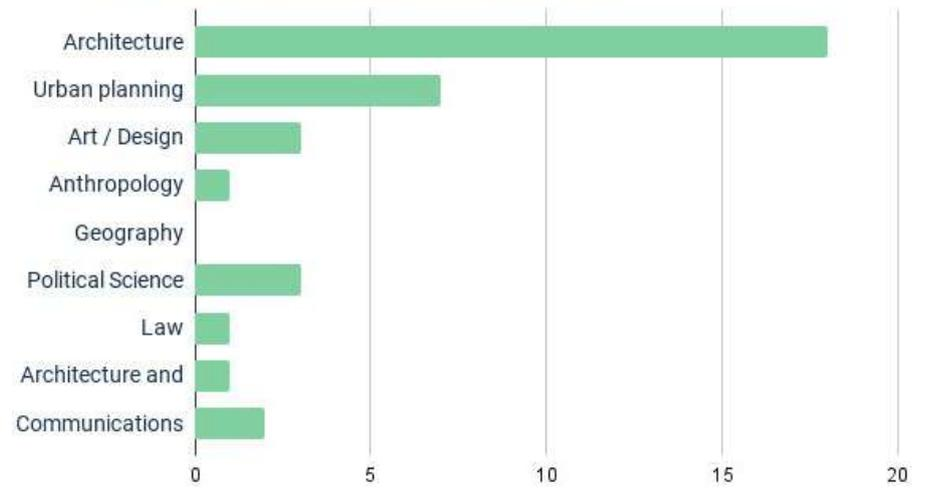

Figure 3: Learner survey (October 2021). Multiple choice question. 24

How would you describe your ethnicity?

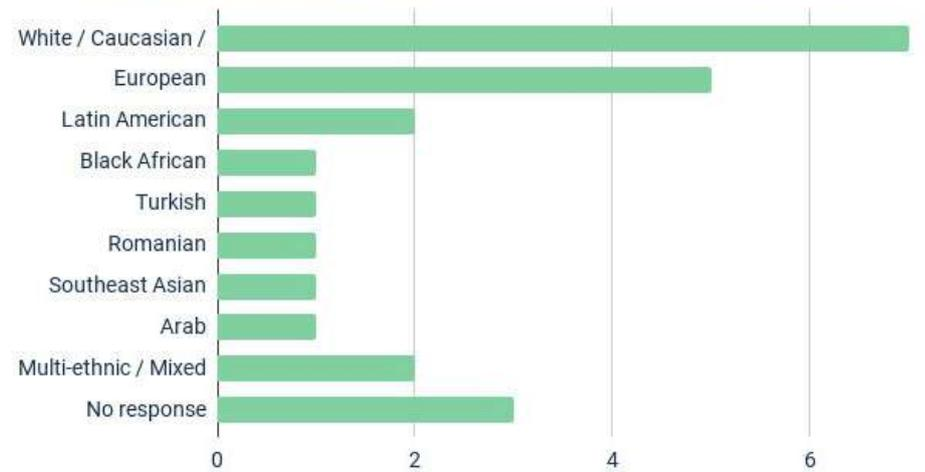

Figure 4: Learner survey (October 2021). Open question, 24 respondents.



Figure 5: Working group 3 (courtyards and neighbourhoods) in Milan. Photo Luisa Durrer.



Figure 6: Workshop in Berlin. Photo Barbara Herschel.

Online activities

The course lasted six months between May and October 2021. It was designed as a blended learning experience made up of both online and offline activities to be carried out among different groups of learners (the whole community, but also the local units at the national level).

Different learning experiences were set up to consolidate the community locally and internationally, offer theoretical and practical insights on the topics of the course, and experiment in the field. Along the course, the community of learners and teachers relied on two main online tools: The Collective Archive and Google Classroom. An overview of these activities is provided in the course summary on pages 3-7. The paragraphs that follow describe the online components of the course.

Remote meetings

During the course, three remote meetings were held to introduce the course as well as the two live workshops (17th May); to reflect on the Berlin live workshop and share findings and outputs from the experience (15th July); and to reflect on both the Milan workshop and the whole course (5th October). These meetings played an important role in building the community of learners and teachers. They allowed us to share and review personal expectations towards the course as well as to gather feedback.

During the remote meetings, the community of learners and teachers carried out team-building activities, shared and discussed their work and had an opportunity to reflect on their experience in small groups via breakout rooms. During the third and final online meeting, the evaluation of the course took place through an activity in which learners were asked to show and describe an object representing what they took away from the course.



Figure 7: Closing meeting online.



Figure 9: Reflection objects collected by the learners.

Open sessions

The Open Sessions were a series of online lectures curated by project partners UdK and S27 in preparation for the live workshop in Berlin. The lectures were complementary to the initiative Stadtwerke Marzahn (mrzn) and explored how resilience can emerge through migration, marginality, exclusion and the current context of the Covid-19 pandemic.

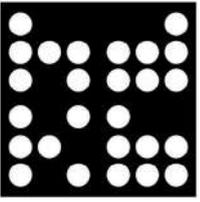

UdK open sessions

Berlin
12.05.2020

Fachgebiet Entwerfen und
Gebäudeplanung
Institut für Architektur
und Städtebau
Universität der Künste
Hardenbergstr 33
10623 Berlin

Markus Bader
Professor
Anna Kokalanova
Wiss. Mitarbeiterin
Juan Chácon
Lehrbeauftragter
Jeanne Astrup-Chauvaux
Tutorin
Antonia Lembcke
Tutorin

research: desinc live
Katharina Rohde
Wiss. Mitarbeiterin

UdK open sessions

As part of our semester's project, and embedded within the broader context of Designing Inclusion LIVE, UdK has designed a series of open sessions. These connect to themes and methods which will be explored during the Practices of Inclusion course, and in particular during the Live Workshop in Berlin. The open sessions hence build up towards the Workshop and we encourage everyone to join. The sessions will not be recorded.

Meeting link: <https://udk-berlin.webex.com/udk-berlin/j.php?MTID=m815324849cfca98df81a247b856f54>

Tue	18.05.	10-12h	Practices of Care (Refugees Welcome Italy)
Tue	25.05.	10-12h	Urban Practice (Markus Bader, Raumlabor Berlin)
Tue	01.06.	10-12h	Subversion & Dissent (Späti Späti)
Tue	08.06.	10-12h	Urban Intervention (Katrin Glanz, tbc)
Tue	15.06.	10-12h	Power & Space (Todosch Schlopsnies, S27)
Tue	22.06.	10-12h	Envisioning (Architects without borders UK)

Figure 8: Programme of Open Sessions hosted by UdK.

Learning provocations and Public Dialogues

Learning provocations are a pedagogical tool used to provoke thought and motivate thinking or investigation. A learning provocation is designed by teachers to elicit independent learning. It can be based on curriculum learning intentions and learners' interests, or designed to cover assessment criteria.

During the course, we used Learning Provocations as an opportunity to create room for learners, teachers and invited speakers to think together and co-design the public-facing moments of the course, named Public Dialogues.

Public Dialogues are events inviting members of the public to discuss with stakeholders and policy makers on issues and topics relevant to future policy decisions. In an educational setting, public dialogues favour constructive conversations amongst diverse groups of learners, teachers and experts on topics which are often complex or controversial.



Figure 10: The Garage, Sheffield S1 Art Gallery Residency. Photo Vishnu Jayarajan.



Figure 11: Gross Domestic Product. Photo EDIT.

They also provide in-depth insights into public opinion and offer a window into understanding people's reasoning.

The novelty of the Public Dialogues held during the course is that their programme and content were co-designed by the learners and the experts involved during the Learning Provocations.

Making the City, Un-Making Architecture?

Date: July 8, 2021.

Together with the feminist design collective EDIT, we reflected on the political possibilities of urban practice. Can urban practice operate as a tool to sustain more equitable ways of making the city? Can planning and design processes based on exploitation and rooted in extractivism be subverted, and if so how?

Narrating the City Differently

Date: September 16, 2021.

Through RESOLVE's approach, we probed into the potentials and implications of narrating the city differently. How can we tell the stories of places and people that have been silenced? Who is entitled to tell these stories, and what are the consequences of re-establishing neglected and suppressed voices?

Collective Archive and Google Classroom

The Practices of Urban Inclusion course relied on two online tools: a virtual learning environment (Google Classroom) and a Collective Archive. Each partner institution contributed to creating both platforms.

The Collective Archive is a repository of relevant open-access materials for supporting learning and teaching activities, it is organized according to the programme's Topics and Learning Methods. The pages contain different types of materials allocated into specific sections: Concepts (introducing to the theoretical aspects of the course); Stories (case studies of local situations as well as research and teaching experiences); and Outputs (materials produced during the course).

The platform Google Classroom was used as a repository of the materials produced along the course (e.g. programmes of activity, timetables, recorded online talks, presentations) and as a communication platform.

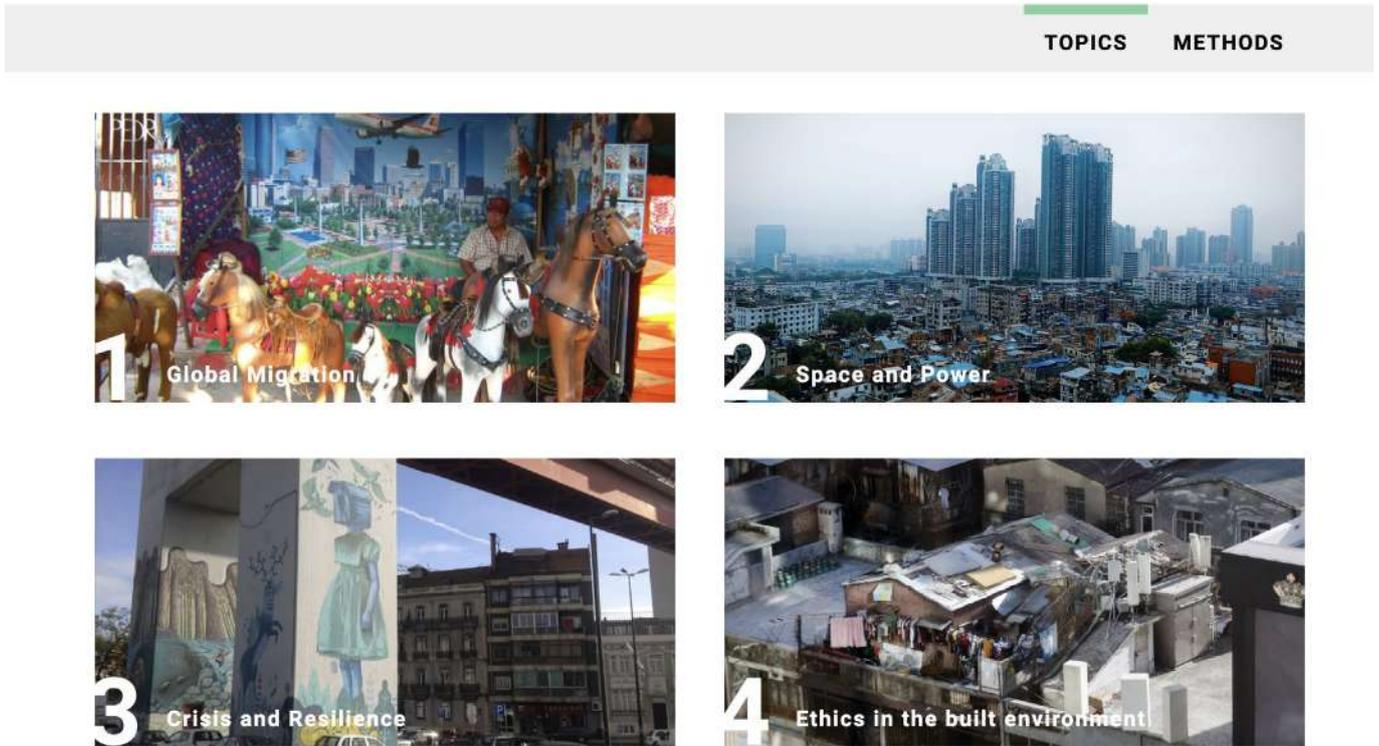

Figure 12: A sample of Topics from the Collective Archive. Source: <https://www.desinclive.eu/toolbox-type/topics/>

Local unit activities

Aims of the local unit

Self-reflection:

Local units were the site to enhance personal reflection and critical thinking about one's positioning within the community of learners. They also allowed learners to share feedback about the course and, especially, the two live workshops.

Community building:

Local units provided learners with an important space to meet each other and build relationships . They allowed the learners and teachers to introduce themselves, share their motivations, and collectively prepare for and reflect upon the live workshops.

Learning journals:

The course introduced learning journals as a tool for learners to take stock of their experience while in progress, through texts, photographs and drawings. Local units provided learners with a space to share and discuss their learning journals.

Participation from home:

In some cases, local units were also activated during the live workshops to co-design and attend activities (both online and on-site) for those who could not travel.

Core activities

One-to-one tutorials to help learners explore their attitudes, expectations and reflections about the course, and to discuss their positionality towards the topics addressed during the course.

Online seminars to tackle and further analyse the core topics of the course and to jointly get prepared for the two live workshops.

Live meetings to create room for bonding and community building, as well as for self-reflection and for evaluating the course in small groups.

_Seminar: mapping as a research tool

We should talk about **critical mapping** : #
mapping is about choosing information and proposing a vision.

What if we want to represent the social relations embedded into a plan?

Sites of critical mapping:

_Production: *which voices do we want to represent?*

_Image: *how to represent the informations?*

_Audience: *who's going to read the map?*

✂ MAPPING

**#Tools
#Tools
#Tools**

**THE URBAN FORM
TIME AND CHANGE
PERCEPTIONS
SPATIAL PRACTICES
SOCIAL NETWORK
THE INVISIBLE SPACE**

HINTS

- G. Hasselt - The Calais Map 2015/17**
- Arcsr - Mapping in Agra and Navi Mumbai 2007 / 12**
- Frank Dresmè - Project 360**
- Christian Nold - Stockport Emotion Map**
- CLUSTER - Cairo - mapping street vendors 2019**
- Bureau d'etudes - European norms of work production**
- Atelier d'Architecture Autogeree - Ecobox**

... (maybe) who is represented in the map should have voice in the way the map is represented!!!



in

..

ets

real thing in San Siro!)

027

Figure 13: Extract from a Learning Journal.

Non' eravamo invece della HOUSE of TIME in BRUGES, siamo passati al ~~collettivo~~ collettivo che ha integrato il progetto ad un PROCESSO di INTEGRAZIONE, da parte delle persone coinvolte. (THE SPECIALS FILM).

RAGAZZI del QUARTIERE di BRUGES che provano da contesti difficili ed ~~sono~~ ~~marginati~~ sono EMARGINATI dalla scuola, lavoro.

L'INTEGRAZIONE anche in questo caso è avvenuta grazie al DIALOGO, ma ~~non~~ ~~è~~ ~~stato~~ ~~il~~ ~~preparato~~ ~~il~~ ~~fare~~.

Quindi dalla una SERIE di STRUTTE e di MATERIALI, permettere a queste persone di FARE QUALcosa, da loro guidanza di LORO INIZIATIVA. Questo ~~ha~~ ~~portato~~ ~~ad~~ ~~una~~ ~~NON~~ ~~ESSENDOCI~~ ~~il~~ ~~fare~~ ~~questo~~ ~~o~~ ~~il~~ ~~fare~~ ~~il~~ ~~figlio~~, e non dovendo essere addebi, il loro LAVORO ERA RICONOSCIUTO e ha permesso loro di ~~non~~ ~~essere~~ ~~marginati~~ ~~o~~ ~~emarginati~~.

IL LAVORO è PARTITO dalla NECESSITA' BASILARI della SOCIALITA', MANCIARE e ~~avere~~ ~~bere~~, ~~avere~~ ~~lavarsi~~.

LAVORO CONDIVISO.

CONTRUZIONE CUCINA CONTRUZIONE DOCCIA

POI SI SONO SVICUPPATE LIVELLI PIU' COMPLESSI DI ~~avere~~ ~~edifici~~, "ISPAZIACIONI", CHE HANNO SEQUITO LO STESSO PROCESSO.

COREALIZATION

DAI REGISTI DI QUASI AMICI, SAMBA E C'EST LA VIE
VINCENT CASSEL FIEDA KATEB
★★★★ "OULI TRACCHIANI L'UNIONE" ★★★★★ "UN REC DI DESICRIAL L'UNION"
★★★★ "HARSHALL SPINOFF"
The Specials
Fuori dal comune
un film di FRED TOUBERO e OLIVIER PASSENI

SHARING IS BASED ON IMPERSONAL PURPOSES

COLLABORATIVE LABORATORY

RICHARD SENNET

Figure 14: Extract from a Learning Journal.

Live Workshops 2021

The two live workshops aim to enhance participants' capacity to work collaboratively and reflexively, engage with diverse stakeholders, map complex urban territories and produce multi-dimensional analyses of places, and envision and test potential change via performative actions and temporary interventions.

Berlin, Germany



Milan, Italy



Berlin live workshop

Theme: Making

The Berlin workshop took place in the district of Marzahn, located on the outskirts of the city. Here, a refugee camp initially set up as an emergency shelter is now one of the largest accommodations for refugees in Berlin.

The workshop engaged with this context through the ‘experimental construction site’ known as Stadtwerke mrzn, which was initiated by S27 in Summer 2020 as a model campus for the new citywide urban practice network. Stadtwerke mrzn utilises arts based methods to explore how local residents can gain agency to transform both their livelihoods and the spaces where they live. The workshop addressed the link between art and architecture and their capacity to contribute to building local resilience in the context of migration and social exclusion – particularly during the current global pandemic. The workshop took a collaborative and cross-disciplinary approach, to understand urban space as a product of multiple relationships, and urban practice as an instrument for social change.



Figure 15: Group discussion during Berlin workshop. Photo Luisa Durrer.

Programme

Monday, 28th June

10-11 Check in, led by Markus Bader & Katharina Rohde (UdK)

11-12 Site Explorations: Walks led by UdK students

remote participants: online introduction to Stadtwerk mrzn,
led by Anton Schünemann/S27

12-13 Introduction to the three scales: UdK students' explorations
and works during the semester. Divisions into three working
groups.

13-14 Lunch break

14-15 Introduction: Working together, led by Todosch Schlopsnies
and Federica Teti, artistic directors

15-17 Getting Ready: Setting up the site for working together

17-18 Cleaning up and reflection round

remote participants: online reflection with ambassadors, led
by London Met and ASF-UK

Tuesday, 29th June

10-12 Meet at S27

Introduction to the work of S27 – Art and Education, led by
Barbara Meyer (managing director S27)

remote participants: the event will be live streamed

12-13 Travel together to Marzahn

13-14 Lunch break

14-17 Working in groups across scales

17-18 Cleaning up and reflection round

remote participants: online reflection with ambassadors, led
by London Met and ASF-UK

Wednesday, 30th June

10-11 Check in, led by Markus Bader & Katharina Rohde (UdK)

11-13 Working in groups across scales

13-14 Lunch break

14-17 Working in groups across scales

17-18 Cleaning up and reflection round

17-19 remote participants: Learning Provocation with ambassadors,
led by Viviana d'Auria (KU Leuven)

Thursday, 1st July

10-11 Check in, led by Markus Bader & Katharina Rohde (UdK)

11-13 Working in groups across scales
remote participants: online introduction to Haus der Statistik,
led by Anton Schünemann/S27

13-14 Lunch break

14-17 Working in groups across scales

17-18 Cleaning up and reflection round
remote participants: online reflection with ambassadors, led
by London Met and ASF-UK

19-21 Optional: Critical Refugee Studies @ Floating University,
organised by common ground UdK

Friday, 2nd July

10-11 Check in, led by Markus Bader & Katharina Rohde (UdK)

11-13 Working in groups across scales
remote participants: online introduction to Berlin Mondiale,
led by Anton Schünemann/S27

13-14 Lunch break

14-17 Working in groups across scales

17-18 Cleaning up and reflection round
remote participants: online reflection with ambassadors, led
by Lonon Met and ASF-UK

Saturday, 3rd July

10-11 Check in, led by Markus Bader & Katharina Rohde (UdK)

11-13 Installation of all works produced during the week

13-14 Lunch break

14-16 Installation of all works produced during the week

16-19 Presentations with guests and celebrations!

Sunday, 4th July

11-13 Final reflection round and cleaning up.



Figure 16: Cooking in Marzhan. Photo Luisa Durrer.

Workshop outputs

Learners were divided into three main groups, each working on a different scale (micro, meso and macro) to assess the relationship between the workshop site and its whereabouts, the living conditions of its inhabitants, and the potential interventions to be implemented on-site.

The micro scale

This level explored a site in Marzahn, surrounded by social housing and refugee homes, where learners were asked to connect to the people and build structures to support the infrastructure. The group also organized a one-week-long workshop for international students.



Figure 17: Montage from Spaces of Resilience, Universität der Künste, 2020/2021.

During the process, the group faced issues of stability, time management, material shortages, and communication barriers. Still, it was able to build a 4-by-4 meters wooden pavilion that the site's visitors can now use. Different seating options were built, and a small high point for the children acts as a treehouse.

The pavilion is built from 6 towers connected through diagonal and horizontal beams giving stability. Tables and benches allow the other sides to stay more open, connecting the previous meeting, the cooking area, and the new room. The group also added a big table to create an inviting space that can be used to eat, talk or work.

The meso scale

This level explored how resilience can emerge in the context of migration, marginality, exclusion and beyond in the current context of the Covid-19 pandemic. Stadtwerke mrzn is located at Otto-Rosenberg-Platz, on the eastern edge of the district Marzahn, which were built during the post-war period, and were belonging to DDR at the time.

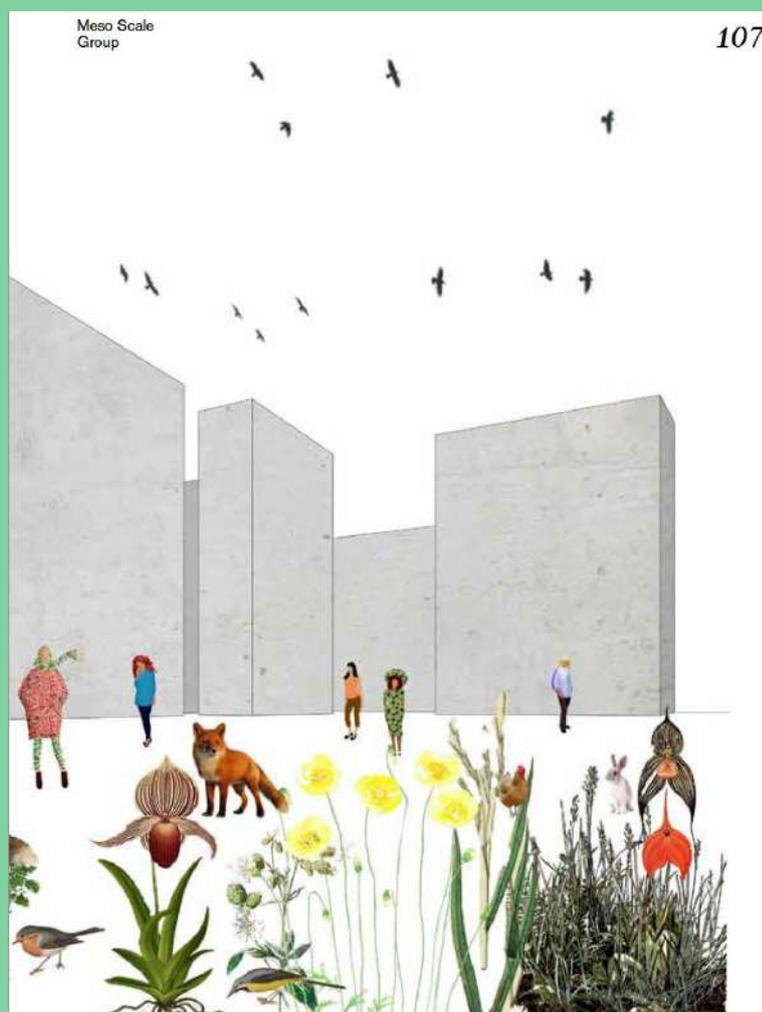

The square is located in the center of an industrial area and is separated from the



Figure 18: Montage and sketch from Spaces of Resilience, Universität der Künste, 2020/2021.

The macro scale

This level looked at Marzahn from a far-reaching perspective. The first approach challenged the dichotomous understanding of city and countryside, center and periphery, towards a more complex spatial analysis.

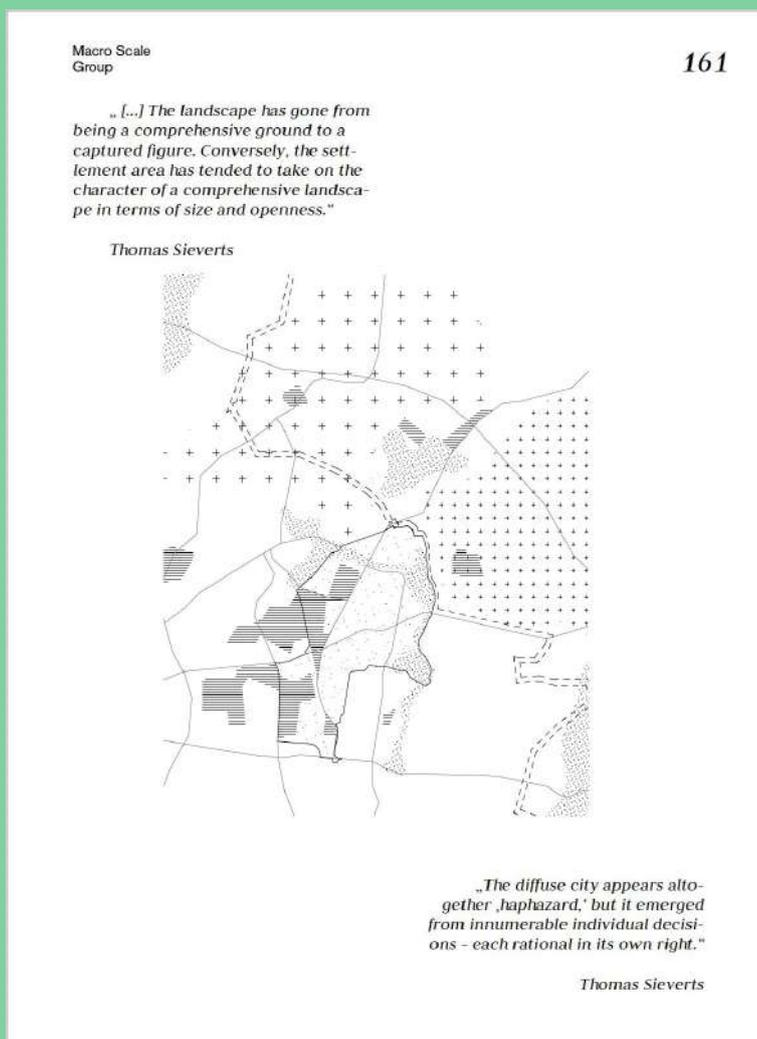

Figure 19: Map from Spaces of Resilience, Universität der Künste, 2020/2021.

To point out the existing qualities of Marzahn as an area of transition between city and countryside. Learners coined the term ‘intercity’ that, on the one hand, connects different urban contexts and, on the other hand, strongly shows its characteristics and realities.

Discovering Marzahn in different modes, learners identified what they called typologies of appropriation - spaces, such as the field, the yard, the bridge, that show specific morphologies that are representative for the structure of Marzahn and, at the same time, contain openness for a new future to be imagined.

Post-workshop activities

On October 15, 2021, a group of Berlin-based learners and teachers went out to Marzahn for a closing live session. They cooked pizzas in the oven on site and shared them with locals. It was also an opportunity to see how things have evolved in Marzahn a few weeks after the conclusion of the live workshop: some new structures emerged, and those built during the workshop have been actively used since then.



Figure 20: Autumn pizza in Mrzn. Photo Barbara Herschel.



Figure 21: Autumn activities in Mrzn. Photo Barbara Herschel.

London local unit: parallel programme

The aim of the Live Workshops was to enhance participants' capacity to work collaboratively and reflexively, engage with diverse stakeholders, analyse complex urban spaces and envision and test potential change via performative actions and temporary interventions.

Three of the learners from the UK cluster could not attend the Berlin live workshop due to restraints related to the Covid-19 pandemic. Therefore, a blend of online and in person activities were organised for the London-based participants that addressed these aims by encouraging participants to engage with their own context, and to compare their experience to what will be happening in Berlin. During the week, UK cluster participants in London explored the same idea of 'making the city' that was addressed in Berlin.

During the week the learners visited sites and projects in Berlin remotely:

- BER site visit: Stadtwerk mrzn
- BER site visit: S27 Art + Education with Barbara Meyer
- BER site visit: Haus der Statistik with Nina Peters
- BER project: Initiative Urbane Praxis with Carla Schwarz

The London Cluster learners also each led site visits in London that were relevant to their own urban practice and learning journey:

- Clitterhouse Farm community project, Cricklewood
- Elephant & Castle latin village
- Clapham Deep Level Shelter and Black Cultural Archives, Brixton

The learners also participated in organizing and hosting the Learning Provocation with EDIT Collective.

Throughout the week, the London-based participants collectively documented stories of making, both from Berlin (based on the online interactions with S27, UDK and the group's ambassadors) and in London (based on self-organized site visits).

A collaborative Tumblr website was created by the learners to trace their collective learning during the workshop and to record the interactions, experiences, ideas and knowledge gathered along the way.

Tumblr link: <https://londoncluster.tumblr.com/archive>

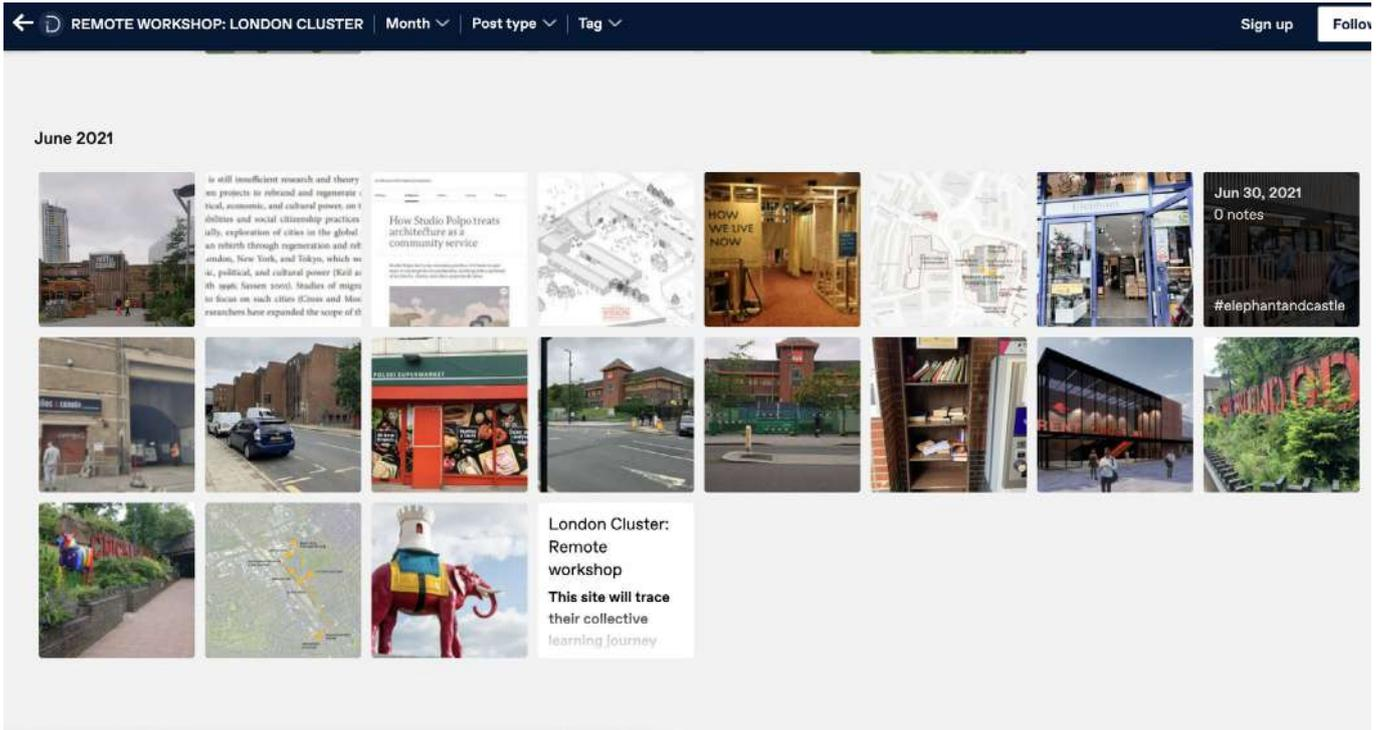

Figure 22: London Local Unity, Tumblr website.

Milan Live Workshop

Theme: narratives of space

The Milan workshop was set in the district of San Siro. San Siro is one of the largest public housing estates in Milan and a large percentage of its population has a migratory background.

Despite its physical proximity to the city centre, the area is generally perceived to be part of Milan's periphery due to its challenging material and social conditions, ranging from intense intercultural and intergenerational conflicts to poor buildings maintenance. At the same time, San Siro is also home to a vibrant network of individuals and organisations – known as Sansheros – who collaborate closely to support local residents and ameliorate living conditions in the neighbourhood. The work of Sansheroes ranges from research-based, policy-oriented initiatives, to the provision of day-to-day services such as legal counseling, language courses, and more.

The workshop engaged with the reality of San Siro and its many stakeholders, addressing questions of diversity, cohabitation and care through collaborative storytelling, mapping and performances.



Figure 23: Group work in San Siro. Photo Niside Panebianco.

Programme

Monday, 6th September

- 10-10:30 Welcome
- 10:30-11 Introduction to the workshop, led by PoliMi & RWI
- 11- 13 Working in groups - Walks with rooted researchers (R. Ferro; P. Grassi; G. Orsenigo; A.Ranzini - Mapping San Siro research group - PoliMi)
- 13-14 Lunch with rooted researchers
- 14-15:30 Working in groups - Establishing the research aims of each group, led by rooted researchers
- 15:30-16 Break and go to main base
- 16-17:30 Seminar - 1. Mapping as a research tool, led by B. De Carli (LMet)

Tuesday, 7th September

- 10-11 Seminar - 2. Local network as devices of inclusion, led by E. Maranghi (Mapping San Siro - PoliMi)
- 11-13 Working in groups - Dialogues with local actors, led by F. Cognetti & S. Pontiggia (PoliMi), G. Baracco & A. Villa (RWI), S. Uberti Bona & A. Priano (Sansheros network)
in collaboration with:
Maria Dellagiacomina & Lucia Ventura - Legal Clinic, Università Bocconi;
Nancy Boktour - Associazione Mamme a Scuola;
Daniel de la Traba Lopez - COOPI;
Valentina Valfrè - Fondazione Soleterre;
Maria Chiara Cela - Cooperativa DarCasa;
Federico Bottelli - Comitato di Quartiere San Siro;
Members of Comitato Abitanti San Siro;
Anna Todeschini - Ass. Alfabeti & Marielle Binken - Shifton
- 13-14 Lunch break with local actors
- 14-16:30 Working in groups @ Off Campus San Siro; Il Nero Distribution space; Shifton space; Colibrì space
- 16:30-17 Break and go to main base

- 17-18 State of the art - Sharing the research wall, led by L. Caistor-Arendar (LMet)
- 20:30 Optional: dinner@P.Sarpi neighbourhood, led by PoliMi local cluster

Wednesday, 8th September

- 10-11:30 Seminar - 3. Unpanicked Multiculturalism. Concepts, places and policies in the cities of difference, led by P. Briata (DASStU - PoliMi)
- 11:30-13 Working in groups - San Siro explorations
- 13-14 Lunch break
- 14-16 Working in groups @ Off Campus San Siro; Il Nero Distribution space; Shifton space; Colibrì space
- 16-17 Reviews with rooted researchers
- 17-18:30 Break and go to main base
- 18:30-19:30 Life journeys - Introductions with local residents, led by PoliMi & RWI, M. Castelli & A. Priano (Sansheros network)

Thursday, 9th September

- 10-11 State of the art - Sharing the research wall, led by L. Caistor-Arendar (LMet)
- 11-13 Seminar - 4. Building emergent bonds for knowledge production: methods and tools, led by PoliMi & RWI
- 13-14 Lunch break
- 14-16 Working in groups - Life journeys: exploring the everyday life of/with the inhabitants
- 16-18 Working in groups @ Off Campus San Siro; Il Nero Distribution space; Shifton space; Colibrì space
- 16-18 Learning Provocation with Resolve, led by KU Leuven & LMet
- 20:30 Optional: aperitif with hosting families & RWI activists and volunteers, led by RWI

Friday, 10th September

- 10-13 Working in groups - Life journeys: exploring the everyday life of/with the inhabitants
- 13-14 Lunch break
- 14-17 Working in groups - Life journeys: exploring the everyday life of/with the inhabitants
- 17:30-18 State of the art - Finalising the outputs, led by L. Caistor-Arendar (LMet)

Saturday, 11th September

- 10-10:30 Introduction to aims of the day, led by PoliMi & RWI
- 10:30 -13 Working in groups - Finalising outputs to present, with rooted researchers @ Off Campus San Siro; Il Nero Distribution space; Shifton space; Colibrì space
- 13-14 Lunch break
- 14-15:30 Working in groups - setting up @ Off Campus San Siro; Il Nero Distribution space; Shifton space; Colibrì space
- 15:30-16 Break and welcoming the audience
- 16-19 Presentations to rooted researchers & local partners
Graphic recording activity led by Marielle Binken (Shifton)
- Celebration w/ rooted researchers, local partners & inhabitants

Sunday, 12th September

- 11-13 Brunch with learners & feedbacks, led by PoliMi local cluster

The research wall

During the workshop, learners were supported in their work by the Research Wall. This tool, which consisted of a series of A1 posters, helped the group to create a visual representation of their own work in progress, take notes about the key findings of a given activity, and produce the first thoughts and reflections about the topics of the workshop. The wall was updated every day and its content was shared among the community of learners and teachers.

Workshop outputs

Learners were divided into four main groups and asked to conduct a short inquiry on four different topics: courtyards and neighbourhood life; commerce and economy; support network for migrants; public space and the street.

The following pages summarise the main focus and findings of these four groups.

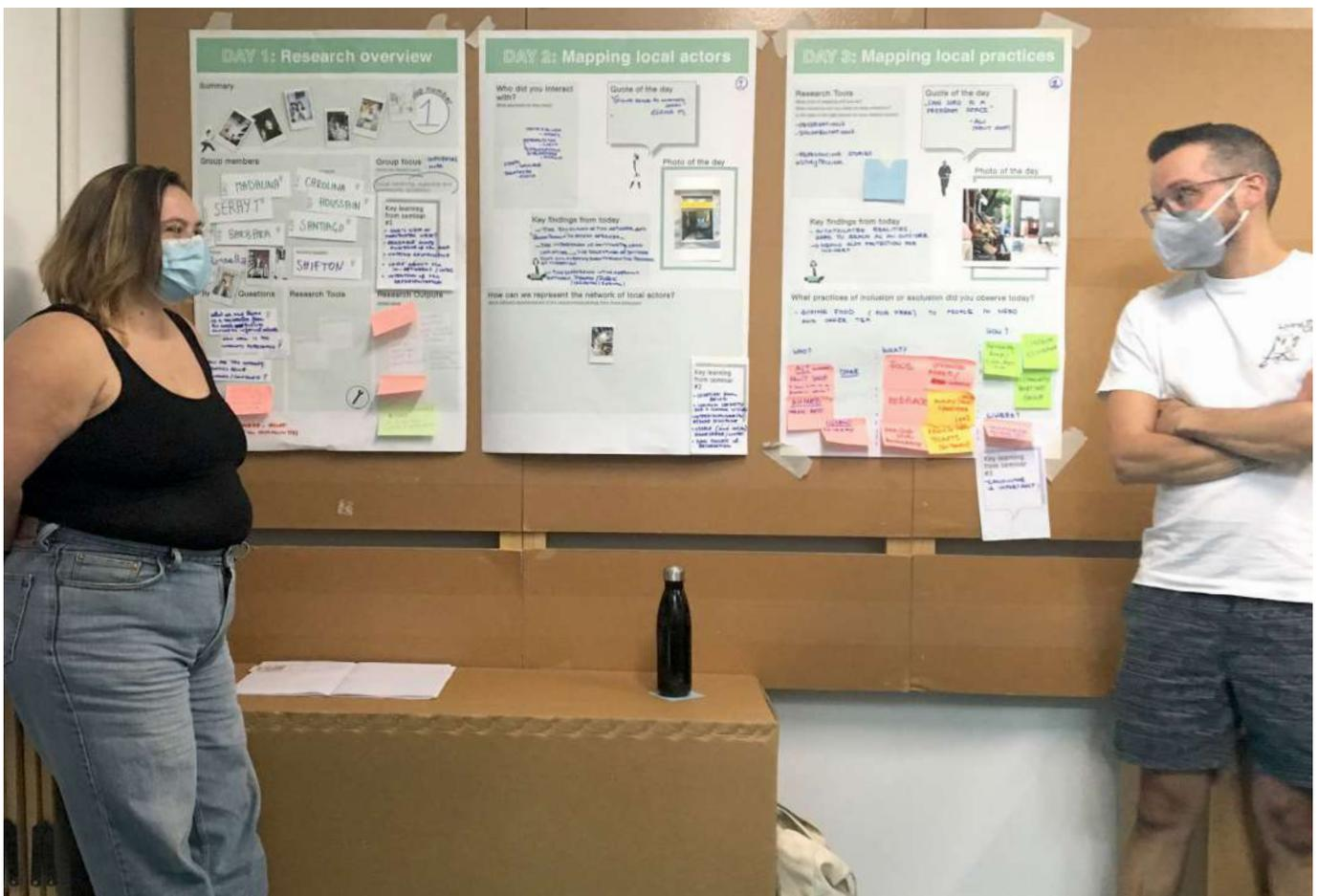

Figure 24: Group 4, research wall. Photo London Metropolitan University.

Group 1: Support networks for migrant communities

The research questions this group explored were: Which are the relational dynamics behind accessing information and services within informal networks in migrant communities of San Siro? What can we learn as researchers from the needs that are covered by informal networks? What are the main tools that people use for accessing these services?

Key findings:

- Hidden realities are hard to reach as an outsider and it takes time to build trust
- A shared language is relevant in the process of accessing information & services
- There is this huge role of passaparola (word of mouth) between the habitants of San Siro to access information & services
- Who has more experience in the process of migration plays a critical role in a migrant community.

The output was a party/gathering in San Siro ('Passaparola night').

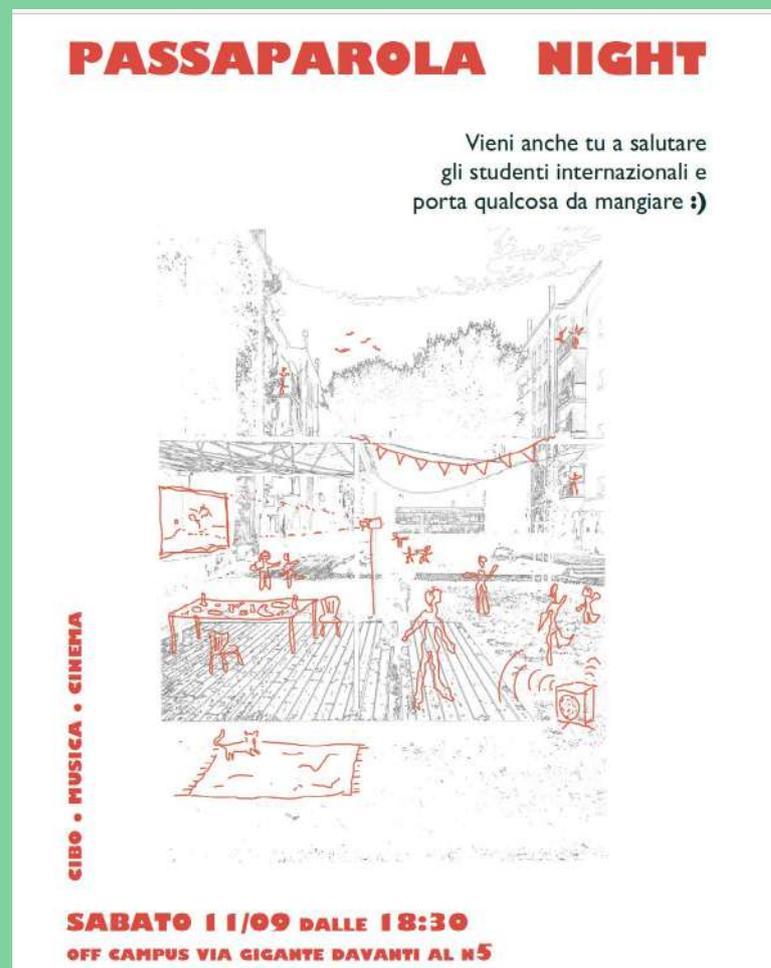

Figure 25: Group 1, event poster.



Figure 26: Group 1 activity planning.

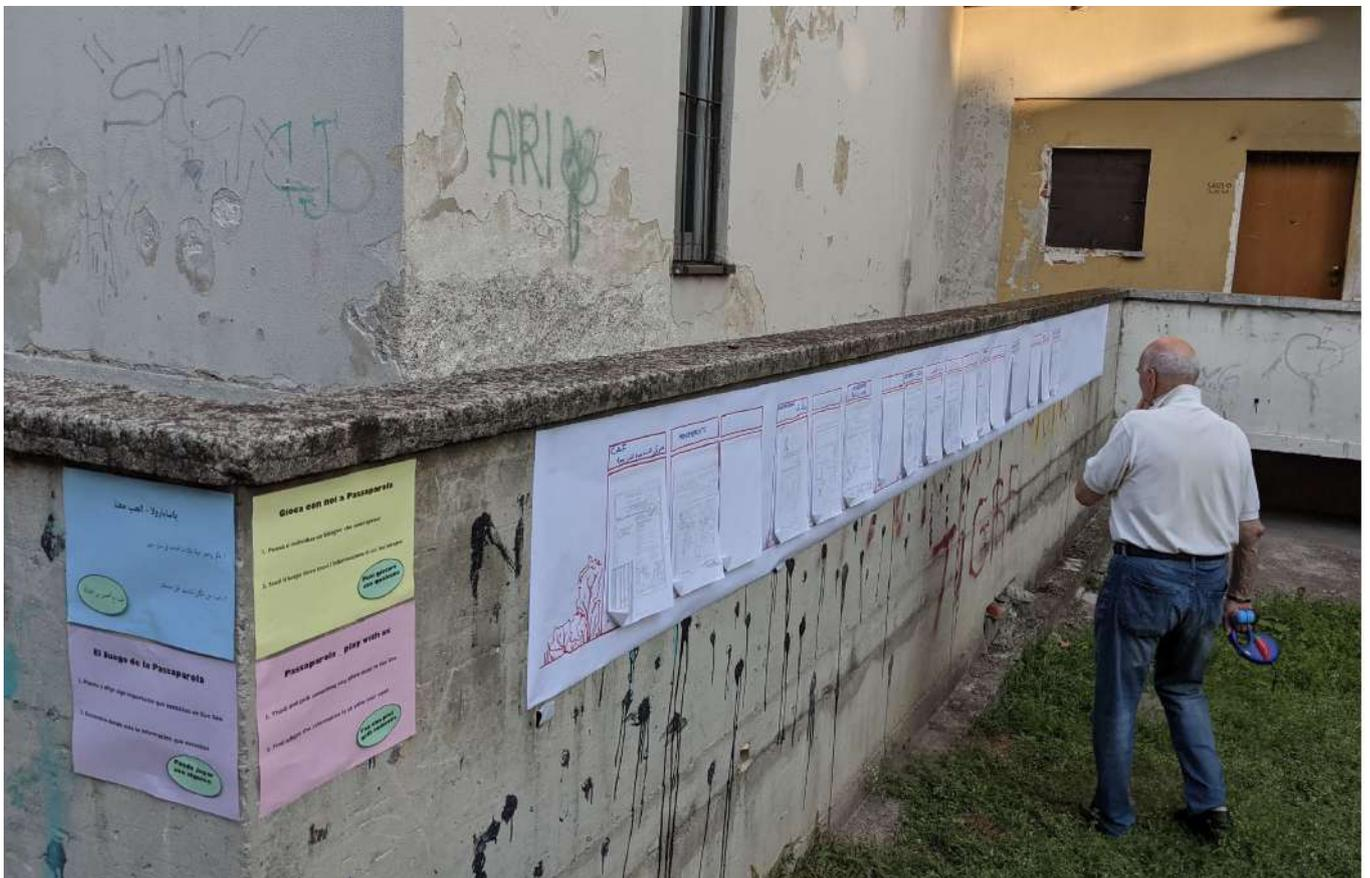

Figure 27: Group 1 final event.

Group 2: Courtyards and neighbourliness

The **research questions** this group explored were: How do inhabitants appropriate and negotiate space in the courtyard (through conflict)? How do inhabitants challenge the normative structure of the courtyard? How do courtyards fit in the established narrative? Is there room for alternative narratives? How can one transcend the established narrative?

Key findings:

- Courtyards are hybrid spaces of negotiation where different realities coexist
- Definitions of public and private space blur and overlap (transcendence)
- Courtyards are spaces caught in a conflict between planning vs. appropriation (subversion), where complexity and stratification of narratives can be found
- Courtyards are spaces of hidden potentiality.

The **output** was a showcase of pictures taken into different courtyards (low- and high-income) paired with audio recordings of ambient sounds.

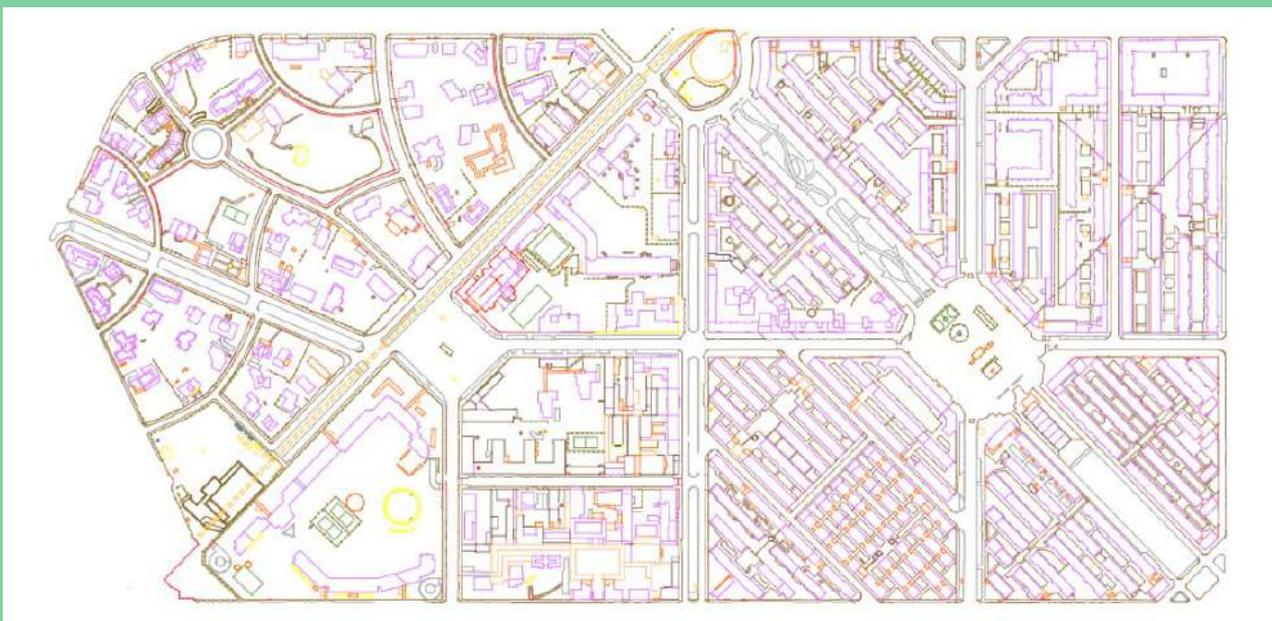

Figure 28: Group 2, Unfolding San Siro.

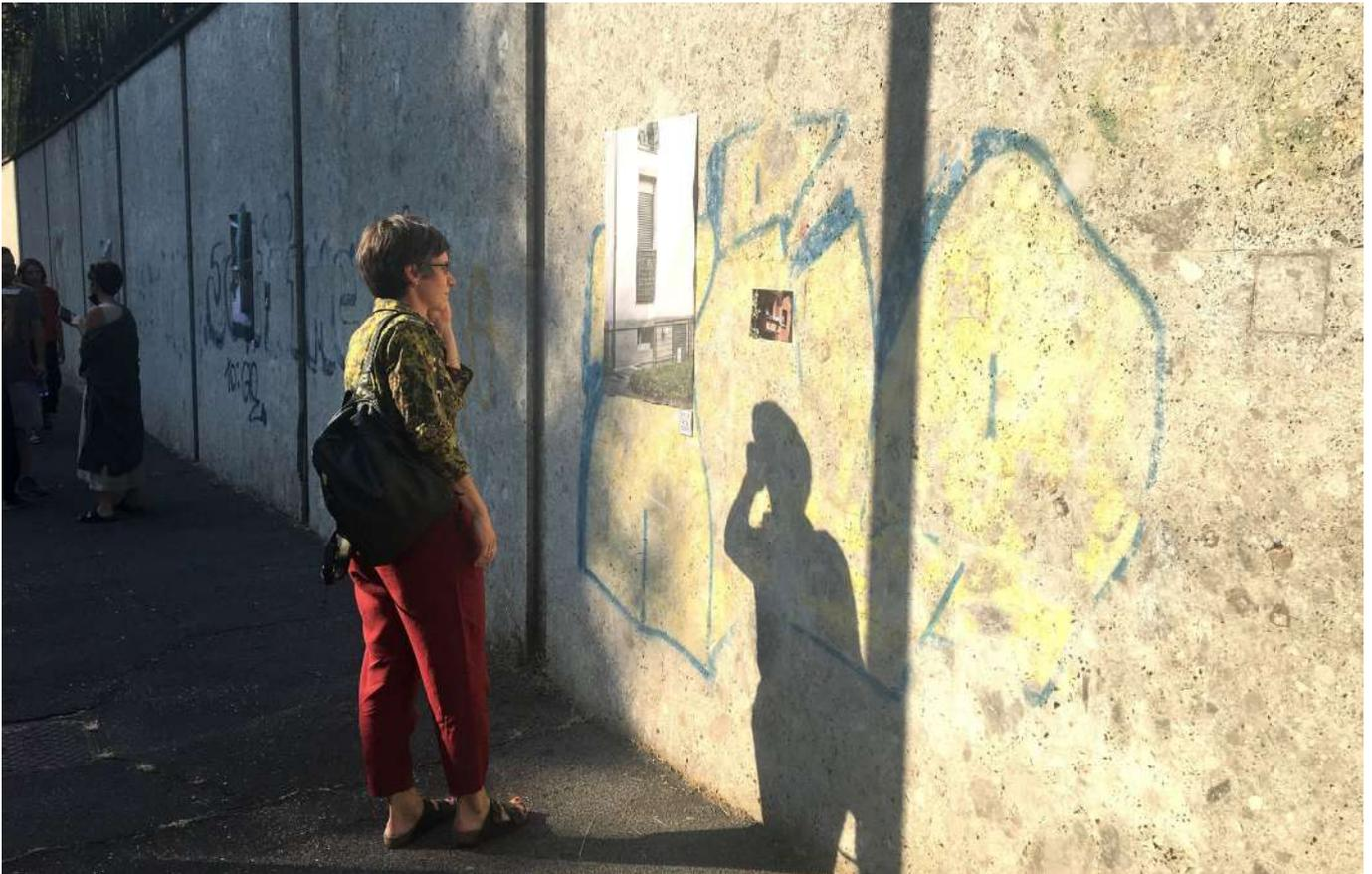

Figure 30: Group 2 final event.



Figure 31: Group 3 final event. Photo London Metropolitan University.

Group 3: Commercial spaces and work

The **research questions** this group explored were: What are some of the ways in which people in San Siro make a living? How does commerce and work in San Siro generate dialogue across places and people? What are some of the networks that emerge from commerce and work activities in San Siro?

Key findings:

- Work trajectories and commercial activities in San Siro vary greatly. Established business owners (from the neighborhood and elsewhere) coexist with people in extremely precarious work situations and everything in between
- Specific commercial and work activities in San Siro and their associated individual narratives illustrate the complex network of relations and trajectories that converge in San Siro across scales.

The **output** was a guided walk where the group told the stories of some inhabitants between precariousness, informality, and life projects.



Figure 32: Group 3. Photo Sebastian Oviedo.

Group 4: Public spaces and the street

The research questions this group explored were: What is the impact of paternalistic interventions in the public realm? What are the spatial practices of women and children in the public realm? What are the different perceptions of San Siro's public realm?

Key findings:

- The interventions have led to certain social spatial practices moving into or out of the public realm
- Women socialising in public realm tends to be the outcome of looking after children and/or informal trading (Roma community)
- Urban realm is divided by invisible boundaries defined by different groups of people.

The output was a guided walk/performance where the group made colleagues and inhabitants “play” with some temporary structures made of outgrowths (e.g., mirrors, chairs, etc.)



Figure 33: Group 4. Photo Sarah ten Berghe.

Conversations with learners

“

“This workshop has been a really great opportunity to share with people from very different backgrounds. As learners coming from abroad, being able to share and collaborate with the inhabitants of San Siro is quite unique— neighborhoods like this are usually not present in the image and narratives that are portrayed internationally of cities like Milan, but are nevertheless very much a crucial part of the city.”

Learner, KU Leuven, Urbanism and Planning



Figure 34: Group 1, Milan workshop.

“

“I am so happy to be a part of the “Desinc Live” project in Marhzan, Berlin, and SanSiro, Milan, neighborhoods in which the majority of residents have immigrant backgrounds. I found this workshop an interactive way to engage people in urban practices in cities. In particular the immigrants and refugees societies with diverse cultures and lifestyles.”

Learner, Politecnico di Milano, MA in Urban Planning and Policy Design



Figure 35: Group 4, Milan workshop. Photo Sarah ten Berghe.



“In these intense days, I feel that we have managed to see a ‘real’ cross-section of the complexity of San Siro. I enjoyed the meetings with activists from the local network, who shared with us a lot of information and different points of view about the neighbourhood. It was personally an important experience because I was able to speak in Arabic, my mother tongue, and explore the issue of individual positioning in research.”

Learner, London local unit



Figure 36: Group 3, final event. Photo Sebastian Oviedo.

Newspaper article

Right after the conclusion of the Milan live workshop, an article appeared in «Il Corriere della Sera», one of the most prominent daily newspapers in Italy. The authors described the activities and reported the words of some learners; pictures depicted the activities and the venues of the event.

Corriere della Sera | Lunedì 13 Settembre 2021

CRONACA DI MILANO

Il laboratorio San Siro ospita 25 universitari e laureati: progettiamo con le comunità





Al lavoro: 25 universitari e laureati a progettare insieme il quartiere. Sotto: la sede del laboratorio. A fianco: la casa popolare di San Siro. In basso: i cortili aperti delle case popolari dove ci siamo sentiti accolti e i giardini chiusi delle case dei ricchi vicino allo stadio. La mattina le lezioni in streaming con i docenti delle quattro università e nel pomeriggio le visite nel quartiere.



«Immersione in periferia» Dall'Europa a caccia di idee

di **Federica Cavadini**

Nella settimana del Salone e del Fuorisalone 25 giovani architetti di università di Londra, Berlino e Lovanio sono arrivati a Milano nella base che il Politecnico ha aperto a San Siro, tra le case Aler intorno piazzale Selnunte. Per sette giorni hanno vissuto solo qui. Hanno visitato piazze e cortili, hanno incontrato residenti e associazioni. Sono stati nelle case e nei negozi, «per una settimana hanno seguito come un'ombra chi vive e lavora nel quartiere. Conoscere e dialogare prima di iniziare a progettare: è l'idea del programma Erasmus+ Design Live per città più inclusive per rifugiati e migranti. Prima tappa a Berlino in luglio, la seconda qui», spiega Francesca Coggett, pedagoga di Architettura e Spazi urbani del Politecnico che ha coordinato il progetto a Milano. Un gruppo con laureati e laureandi in ar-

nel cortile fra i caseggiati Aler. Un gruppo è partito da Selnunte, il piazzetto degli incontri con la polizia di questa primavera; «dopo i discorsi di aprile il Municipio ha scelto di eliminare le parchine come misura di sicurezza, noi ne abbiamo realizzato una temporanea, con uno specchio in ortogonale e tre cassetti e da lì abbiamo sviluppato il tema dell'uso di spazio pubblico». Altri studenti hanno esplorato «le due San Siro»: «Con il contrasto fra i

cortili aperti delle case popolari dove ci siamo sentiti accolti e i giardini chiusi delle case dei ricchi vicino allo stadio. La mattina le lezioni in streaming con i docenti delle quattro università e nel pomeriggio le visite nel quartiere. «In terzo gruppo ha studiato i luoghi di scambio informale come il portacchiere e il fruttivendolo — dice Coggett — sono gli "hub" dove i migranti si incontrano e si passano informazioni, per trovare lavoro o un posto letto». Altri hanno lavorato su «traiettorie di vita del migrante a San Siro». Hanno raccolto storie, «nel ristorante di un pentavito con due lauree, alla bancarella di una donna rom». «Abbiamo molto da imparare anche dagli abitanti e dalle associazioni di un quartiere che non è presente nelle mappe di Milano a livello internazionale ma ne è

Off campus



Figure 37: “Il Corriere della Sera”, Cronaca di Milano, September 13, 2021.

Project partners

The project team includes 18 educators, researchers and practitioners from four universities and three civil society organisations across four European countries.



Politecnico di Milano (Italy)

The team of Politecnico di Milano is based in the San Siro neighbourhood in Milan. The team works closely with Politecnico's social responsibility programme: Polisocial, and contributes to Mapping San Siro, a live lab committed to working with San Siro's residents to co-produce stories of the neighbourhood and scenarios for its transformation.

Team: Francesca Cognetti (Coordinator), Stefano Pontiggia, Martin Broz and Ida Castelnuovo

Francesca Cognetti is Associate Professor of Planning and Urban Policies at the Politecnico di Milano and the Rector's Delegate to Public Engagement. Her teaching and research focus on public/social housing and social inequalities. She has coordinated numerous action-research initiatives in deprived neighbourhoods, with a focus on the context of Milan.

Stefano Pontiggia is a Post-doc research fellow in Anthropology at Politecnico di Milano. His inquiries focus on power, state institutions, migration and political asylum. He has carried out ethnographic research in Italy and Tunisia.

Martin Broz holds a PhD in Regional Planning. He explored issues related to social housing and urban growth in Milan and Barcelona. He is experienced in teaching and he presently works in the programming and monitoring of social responsibility projects at the Politecnico di Milano.

Ida Castelnuovo holds a PhD in Regional Planning and has conducted postdoc research on participatory processes, local governance, urban decision-making and public engagement of universities. She is a project manager at Polisocial, the social responsibility programme of Politecnico di Milano.

Refugees Welcome Italia (Italy)

RWI is a non-profit organisation based in Italy and a member of the Refugees Welcome international network. The organisation aims to promote cultural change in society by involving citizens in supporting refugees and asylum seekers through hosting, mentoring and volunteering; and by advocating for policy change at the local and national levels.

Team: Giorgio Baracco (Coordinator) and Lucia Oggioni and Angelica Villa

Giorgio Baracco is a jurist specialising in International Relations. As programme coordinator of Refugees Welcome Italia, his objective is to combine social innovation with digital transformation and economic sustainability through a cooperative and sharing approach.

Lucia Oggioni is service designer at Refugees Welcome Italia. Her focus is on the development of projects from analysis up to implementation. She strongly believes in the power of design as a tool for discovering new ways of doing things and bettering people's lives.

Angelica Villa has a degree in International Relations. In her professional experience she has developed skills in cultural and social planning, social activism and urban regeneration. In RWI she works as a Project Manager.

KU LEUVEN

Ku Leuven (Belgium)

The team at KU Leuven explores socially engaged spatial practice in the context of globalisation and rapid urban transformations. By developing reflective forms of urban practice that can deal with a diverse range of contextual conditions, the team's research and teaching emphasize the relevance of critical thinking and of working across scales.

Team: Viviana d'Auria (Coordinator) and Katharina Rohde (2019-2020)

Viviana d'Auria is an architect, urbanist and Associate Professor in International Urbanism at the Department of Architecture, KU Leuven. Exploring "practiced" architecture is an integral part of her research, within a more general interest in the trans-cultural construction of cities and their contested spaces.

Layla Zibar's PhD research - KU Leuven (Belgium) & BTU (Germany)
- explores forced displacements urbanism in the Kurdistan Region of

Iraq. She focuses on the geopolitical and socio-spatial interdependent networks triggering dwelling/homing processes in Syrian refugee camps. She is currently an Urban Researcher in the Refufam project/ Gent University (Belgium).



Universität der Künste Berlin (Germany)

The team at Universität der Künste Berlin works at the intersection between art and social action to address complex urban issues such as those relating to humanitarian crises, displacement, migration and social diversity. Teaching activities are strongly interdisciplinary and aim to foster a culture of openness and experimentation in art and design.

Team: Markus Bader (Coordinator) and Katharina Rohde (2021-2022)

Markus Bader is an architect and Professor of Architecture and Building Planning at the Berlin University of the Arts (UdK). He is a member of raumlabor and the Berlin Council of Arts. He is among the initiators of the “Haus der Statistik” and co-author of renowned artworks involving public space, urban commons and marginal populations.

Katharina Rohde is an urban practitioner working internationally at the intersection of architecture, urban design, art and activism. She holds a practice-based PhD from the International Center of Urbanism (ICoU), Department of Architecture at KU Leuven in Belgium through which she explored questions on “How (do) we live together? Everyday Acts of Citizenship and Urban Practice/s in post-migratory Berlin and Johannesburg”. Since September 2021 Katharina is Guest Professor for Urban Design at the Jade University of Applied Sciences in Oldenburg, Germany.



Schlesische27 (Germany)

S27 Art and Education develops experimental projects for and with young people. By encouraging creativity and artistic expression, the aim of S27 is to enable young refugees to discover their own talents, learn German, understand local structures, and eventually find a job or apprenticeship in Berlin.

Team: Anton Schünemann (Coordinator), Vera Fritsche, Anna Piccoli, Federica Teti and Todosch Schlopsnies

Anton Schünemann is a graduate of Bauhaus-University Weimar and has worked for several cultural foundations and media agencies. Since 2014 he is the programme coordinator of S27 – Art and Education, where he has been responsible for the development of various projects with/for refugees.

Vera Fritsche is a state-recognised social worker with an educational background in landscape architecture. She is experienced in child and youth welfare and in socio-cultural projects. She has been the pedagogical director of S27.

Anna Piccoli holds a Research Master in Media Studies and has a multidisciplinary background. At S27, she belongs to the Project Office team of the “Initiative Urbane Praxis” and contributes to various administrative and project management activities. Previously, she collaborated with a research institute for communication and health in Lugano and with cultural organisations in Amsterdam and worked as a project manager and researcher on projects funded by the European Union, leading tender acquisitions for a Brussels-based company.

Federica Teti and Todosch Schlopsnies: Since 2015, architect and graphic designer Federica and sculptor and performer Todosch have been taking a participatory approach in their work with children, teens, and adults (from refugee and non-refugee backgrounds). In workshops of varied format, the course participants build, garden, invent, and play. The main focus, besides creating the direct experience of cultural participation across all boundaries of origin and language, is to achieve something together that would never have been possible alone, and to also have lots of fun while doing it. Artistic direction of the pilot project Stadtwerk mrzn (S27) since 2020.



London Metropolitan University (United Kingdom)

The team at London Metropolitan University experiments with critical spatial practice through live projects set in both local and international settings. The group’s research and teaching explore architecture as a method to engage with the cultural and political dimensions of urban change.

Team: Beatrice De Carli (Coordinator) and Lucia Caistor-Arendar

Beatrice De Carli is a Reader in Urbanism at London Metropolitan University, and a Managing Associate at Architecture Sans Frontières–UK. Her research and teaching employ a collaborative, design-based approach to address issues of equity, diversity and inclusion in the making of urban space.

Lucia Caistor-Arendar is an urban practitioner who combines social research, civic design and education to create opportunities for the production of more social cities. Lucia is a Research Fellow at London

Metropolitan University and is also an Associate of Architecture Sans Frontières–UK and a Senior Associate at the research organisation Social Life.



Architecture Sans Frontières-UK (United Kingdom)

ASF-UK is a non-profit design organisation that builds the capacity of urban practitioners and communities to participate in the co-production of more equitable cities. The organisation works in partnership with civil society groups, local governments and academic institutions both in the UK and internationally.

Team: Rowan Mackay (Coordinator) and Tahmineh Hooshyar Emami

Rowan Mackay is an urban designer with a background in participatory planning and project management. He is Project Lead at Community Led Housing London and has lectured at various universities. Rowan is a Managing Associate of ASF-UK.

Tahmineh Hooshyar Emami is an Architect at the London-based AHMM, a Design Tutor at Loughborough University and Associate/ Researcher at Architecture Sans Frontières–UK. Her research interest and teaching revolve around ephemeral urbanisms, power and politics, critical creative investigations into spaces of migration, and borderland conditions

Appendixes

The appendix includes the following documents:

- Berlin live workshop programme
- Berlin live workshop output
- Milan live workshop programme
- Milan live workshop output
- Crescere a San Siro. Un'esperienza condivisa. Reportage per immagini e rime



2021



Practices of urban inclusion



Live Workshops



Live Workshops 2021

The two live workshops aim to enhance participants' capacity to work collaboratively and reflexively, engage with diverse stakeholders, map complex urban territories and produce multi-dimensional analyses of places, and envision and test potential change via performative actions and temporary interventions.

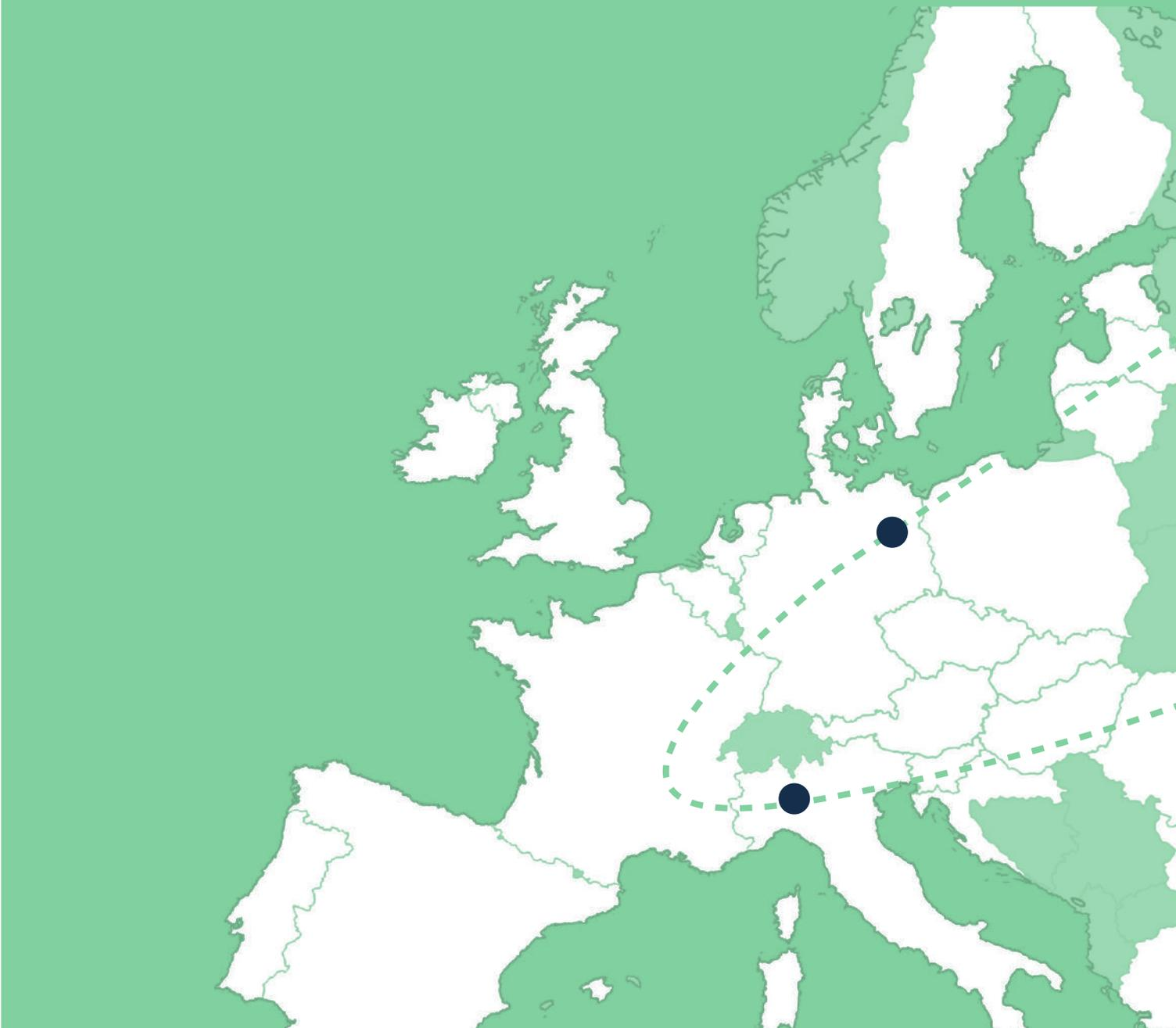

Berlin, Germany

The Berlin workshop will take place in the district of Marzahn, located on the outskirts of the city. Here, a refugee camp initially set up as an emergency shelter is now one of the largest accommodations for refugees in Berlin. The workshop will engage with this context through the 'experimental construction site' known as Stadtwerke mrzn, which was initiated by S27 in Summer 2020 as a model campus for the new citywide urban practice network.

Stadtwerke mrzn utilises art-based methods to explore how local residents can gain agency to transform both their livelihoods and the spaces where they live. The workshop will ask how art and architecture can contribute to building local resilience in the context of migration and social exclusion – particularly during the current global pandemic. The workshop will take a collaborative and cross-disciplinary approach, to understand urban space as a product of multiple relationships, and urban practice as an instrument for social change.



Otto-Rosenberg Platz, Marzahn, Berlin.

Milan, Italy

The Milan workshop will be set in the district of San Siro. San Siro is one of the largest public housing estates in Milan and a large percentage of its population has a migratory background. Despite its physical proximity to the city centre, the area is generally perceived to be part of Milan's periphery due to its challenging material and social conditions, ranging from intense intercultural and intergenerational conflicts to poor buildings maintenance. At the same time, San Siro is also home to a vibrant network of individuals and organisations – known as Sansheros – who collaborate closely to support local residents and ameliorate living conditions in the neighbourhood. Their work of Sansheroes ranges from research-based, policy-oriented initiatives, to the provision of day-to-day services such as legal counselling, language courses, and more. The workshop will engage with the reality of San Siro and its many stakeholders, addressing questions of diversity, cohabitation and care through collaborative storytelling, mapping and scenario building.



San Siro neighbourhood, Milan.

Berlin, Germany

Theme: Making

The seven-day live workshop in Berlin will take place in the district of Marzahn. The specific site we will explore is located around the Otto-Rosenberg Platz at the Eastern edge of the district and not far from its border with the state of Brandenburg. The square comprises the centre of an industrial site and is separated from the residential area by a multilane street and the suburban railway. In 2015 an emergency camp for refugees opened in a former office block nearby the square, which in the course of 2016 has been turned into a community camp. With a capacity of hosting 900 persons, the camp is one of the biggest in the district - and the city. Currently, 450 persons live in the camp of which 180 are children, they origin predominantly from Syria, Eritrea, Albania.

Our engagement will be settled within the context of the 'experimental construction site' of the Stadtwerke mrzn, run by our partner institution the youth and cultural organisation S27 - Art and Education from summer 2020. The overall idea of Stadtwerke mrzn is to create common ideas for open spaces, new perspectives for job creation, and an inclusive urban development collaboratively with the different stakeholders involved. The S27 team is conducting workshops with the different communities at place and artists/urban practitioners from across the city. The workshop group will operate as a support structure, and step into a longer term work process through a temporal mode of supporting where desired.

The Workshop will engage with the 'edge condition' and explore how to build resilience in the context of migration, marginality, exclusion, and furthermore in the current light of the pandemic. Through this lens, 'making cities' will be perceived from an inside perspective and upon the alliances between urban planning, architecture, art, social movements and bottom-up initiatives and their aim of designing (social) public infrastructures and their perception of architecture as an instrument for progressive social change. We will engage with topics such as: the context of Migration, ethics, subversion and dissent, power and space, care, social impact of the built environment, urban practice.

The aim of the (two) workshop(s) (in Berlin and Milan) is to improve the skills of learners in exploring original ways to engage with social realities of local networks and communities and identifying emerging issues, producing in-depth analysis, envisioning and testing potential change via performative actions and temporary interventions.

During the workshop, the participants will work across three scales: the micro-scale of the 'experimental building site', the meso-scale of its immediate surrounding (the camp, the residential area, the nature reserve etc) and the macro-scale that is the district and its context within and for the city of Berlin.

Everyone will be asked to engage in a collective process of making, that includes cooking, thinking, sharing, exchanging, caring and celebrating.

IMPORTANT: Due to the current pandemic, local measures have to be applied which means that we will work in smaller groups, keep the distance, and wear masks!

Venues

Main workshop site: Stadtwerk mrzn

Address: Otto-Rosenberg-Platz, 12861 Berlin

The site is located at Otto-Rosenberg-Platz in Marzahn opposite the large circus tent of Cabuwazi.

Link: <https://goo.gl/maps/o6ZoKGffH5WiBDfi6>

To get there: S-Bahn (S7) stop Raoul-Wallenberg-Straße

Tuesday's meeting: S27 – Kunst und Bildung

Address: Schlesische Str. 27b, 10997 Berlin-Kreuzberg

Link: <https://goo.gl/maps/XzE4TkH3BVINTQQT8>

Programme

Monday, 28th June

- 10-11 Check in, led by Markus Bader & Katharina Rohde (UdK)
- 11-12 Site Explorations: Walks led by UdK students
remote participants: online introduction to Stadtwerk mrzn,
led by Anton Schünemann/S27
- 12-13 Introduction to the three scales: UdK students' explorations
and works during the semester. Divisions into three working
groups.
- 13-14 Lunch break
- 14-15 Introduction: Working together, led by Todosch Schlopsnies
and Federica Teti, artistic directors
- 15-17 Getting Ready: Setting up the site for working together
- 17-18 Cleaning up and reflection round
remote participants: online reflection with ambassadors, led
by London Met and ASF-UK

Tuesday, 29th June

- 10-12 Meet at S27
Introduction to the work of S27 – Art and Education, led by
Barbara Meyer (managing director S27)
remote participants: the event will be live streamed
- 12-13 Travel together to Marzahn
- 13-14 Lunch break
- 14-17 Working in groups across scales
- 17-18 Cleaning up and reflection round
remote participants: online reflection with ambassadors, led
by London Met and ASF-UK

Wednesday, 30th June

10-11 Check in, led by Markus Bader & Katharina Rohde (UdK)

11-13 Working in groups across scales

13-14 Lunch break

14-17 Working in groups across scales

17-18 Cleaning up and reflection round

17-19 remote participants: Learning Provocation with ambassadors,
led by Viviana d'Auria (KU Leuven)

Thursday, 1st July

10-11 Check in, led by Markus Bader & Katharina Rohde (UdK)

11-13 Working in groups across scales
remote participants: online introduction to Haus der Statistik,
led by Anton Schünemann/S27

13-14 Lunch break

14-17 Working in groups across scales

17-18 Cleaning up and reflection round
remote participants: online reflection with ambassadors, led
by London Met and ASF-UK

19-21 Optional: Critical Refugee Studies @ Floating University,
organised by common ground UdK

Friday, 2nd July

10-11 Check in, led by Markus Bader & Katharina Rohde (UdK)

11-13 Working in groups across scales
remote participants: online introduction to Berlin Mondiale,
led by Anton Schünemann/S27

13-14 Lunch break

14-17 Working in groups across scales

17-18 Cleaning up and reflection round
remote participants: online reflection with ambassadors, led
by London Met and ASF-UK

Saturday, 3rd July

10-11 Check in, led by Markus Bader & Katharina Rohde (UdK)

11-13 Installation of all works produced during the week

13-14 Lunch break

14-16 Installation of all works produced during the week

16-19 Presentations with guests and celebrations!

Sunday, 4th July

11-13 Final reflection round and cleaning up

Contacts

Organisation at Marzahn

Vera Fritsche (S27)

Phone: +49 1774287888

Email: v.fritsche@s27.de

General information while in Berlin

Anna Piccoli (S27)

Phone: +49 1746076047

Email: a.piccoli@s27.de

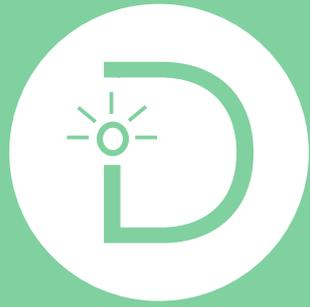

Spaces of Resilience

Universität der Künste

2020/2021

Content

1. Intro

2. Exploring Resilience

3. Research Mapping

4. Mirco Scale

The Site and its Surroundings

Actors and Users on Site

Existing Transient Architecture

In Preparation for the Workshop

Work Plan

The Workshop

Documenting the Designs of the Workshop

Narrating the Workshop

5. Meso Scale

Analysis - Mapping the Area

Cohabitation

Method

Workshop Action

Interviews

6. Macro Scale

How we worked...

Intro Intercity

Manifest of Soziobiodiversity

Vision of Marzahn

Typologies of Appropriation

Workshop Action

7. Milano Workshop

8. Impressum

Intro

Spaces of Resilience

In pandemic times, the call for designing spaces that support our resilience and resistance has moved into focus again. What can resilient spaces look like? What do they feel like? Are these spaces public or do we need individual spaces to support our resilience? Where do such spaces already exist in the city, what niches or open spaces can we occupy for this purpose, what (social) connections do we have to make in the process, how can these be created (under the rules of social distancing)? What does resilience actually mean for the individual? How do we resist and against what?

The resilient design of spaces is not only important in the current situation of the global pandemic - but makes its urgency clear once again. But also in the context of other „crises“ - whether of an ecological, social or political nature - our resilience will (be) increasingly demanded. And especially for so-called social „marginalised groups“, places play a role in which resilience can develop and manifest itself. The joint development and co-production of resilient spaces will therefore be an important task for (future) city makers and architects.

In interaction with the initiative „Stadtwerke Marzahn“ (mrzn), which has been run as an „experimental construction site“ by the art and cultural institution Schlesische 27 since summer 2020, we will explore how resilience can emerge in the context of migration, marginality, exclusion and beyond in the current context of the Covid-19 pandemic. Stadtwerke mrzn is located at Otto-Rosenberg-Platz, on the eastern edge of the district of Marzahn and not far from its border with the state of Brandenburg. The square is in the centre of an industrial area and is separated

from the residential area by a multi-lane road. Also on the square is the Don Bosco Centre, a youth project with a focus on social work and youth welfare. There is also a privately run housing complex for the homeless and the Circus Cabuwazi, which acts as a social hub for children and young people from socially disadvantaged backgrounds. In 2015, an emergency camp for refugees was opened in a former office building, which was converted into a community camp in the course of 2016 and now mainly accommodates families. With a capacity of 900 people, the camp is one of the largest in the district - and in the city.

Together with the various actors on site and the makers around the Stadtwerke mrzn, we will get to know and further develop new alliances between urban planning, architecture, art, social movements and bottom-up initiatives during the semester. ‚City-making‘ will be explored from an inside perspective and an understanding of architecture as an instrument for progressive social change will be generated. By means of the (temporary) design of (social) public infrastructures, ideas for resilient spaces will emerge concretely and visions for their longer-term anchoring in the context of current urban development programs will be considered.

The studio takes place within the framework of the international action research project „Designing Inclusion“ (DESINC) LIVE: Designing and Learning in the Context of Migration“. Experimental teaching and educational formats will be developed, tested and evaluated horizontally together with learners and educators of architecture and urban planning, refugees, and civil society initiatives. New perspectives of ‚city-making‘ will be promoted through social awareness and critical thinking and action, exploring issues such as migration, subversion and dissent, power and space, care and ethics, social impact of the built environment and urban practice. The studio is part of an international educational programme and includes virtual formats of shared learning as well as two live workshops in Berlin and Milan (pandemic situation permitting).

01

mrzn
source: Vera Fritsche

02

mrzn
source: Nils Koenning



Exploring Resilience

What does
resilience mean
to you ?

Spaces of resilience evolve in manifold forms. They can be introvert spaces, e.g. in the context of a home, but they can also be more extrovert and manifest as shared spaces where different actors join forces for common interests or struggles. Sometimes the line between intro- and extrovert is not so clear cut and in particular in the context of vulnerability and displacement boundaries get blurred. In this first exercise, we will observe and explore the complexity of spaces of resilience through drawing and collage. The first exercise aims to draw a common ground between the participants and the overall topic of the studio.

The extrovert and the introvert

In a first step (one week), reflect on your personal spaces of resilience that have emerged in the context of the Covid-19 pandemic. Where did they appear? What did they look and feel like? Which items/objects were important to have? How did this particular spaces support you to strengthen your resilience? Did you connect with others? How?

The second step (one week) is a group exercise and you are asked to work in pairs and to engage with the extrovert spaces of resilience. What strikes you from our first exploration in Marzahn? Do you know other spaces of resilience in the city that have similar approaches and add to the building of resilience for a larger group of people? Who are the actors of these spaces? How do they contribute to support each others resilient capacities?

What does resilience mean to you?

01

02



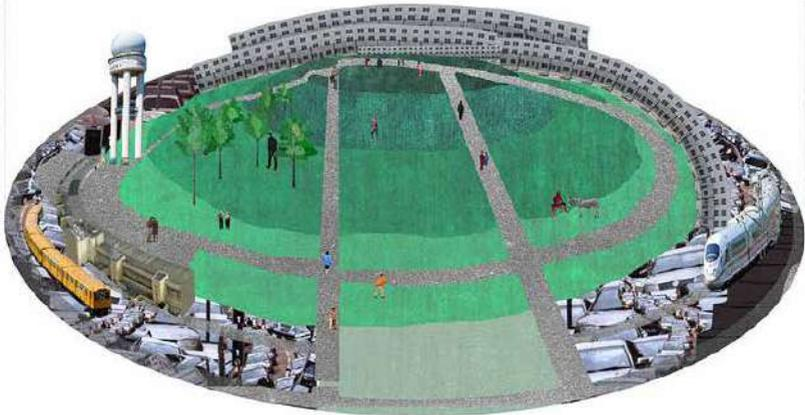

01

02

Eda Akartuna

03

Hanna Schmitthenner

What does resilience mean to you?

01

16

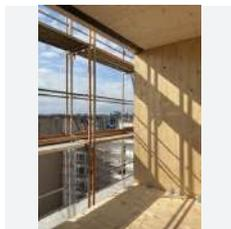
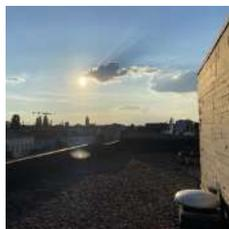
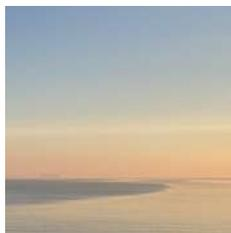

01

Sophie Frehse

02

Luisa Pohlmann

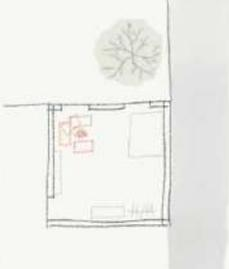

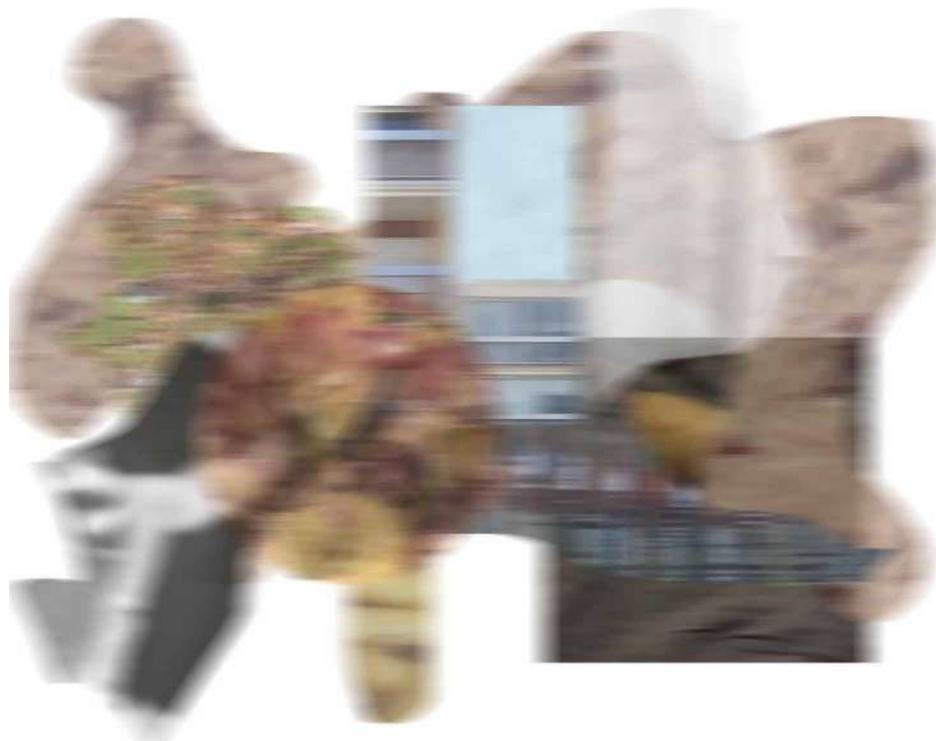

01

Kaspar Jamme

02

Barbara Herschel

Protokoll

personal spaces of resilience

**Der andere Raum
und die Geschichten
zwischen hier,
jetzt, damals**



*Ich tippe.
Es klingelt.
Ich lese.
Ich bin hier aber dort denke ich.
Wir drücken die Worte durch die
Bildschirme und sind nicht allein.
Das Grinsen bleibt noch eine Weile über
das letzte Meme.*



**Das Café,
die Bartische draußen auf der Straße
und die Parkbank**

*Flüchtig unbekannte Wesen.
Gleiche Handlung, gleicher Durst.
Kaffee, Wein oder das Gespräch.
Wir erkennen uns von gestern
und letzter Woche.
Nicken uns still zu und freuen uns
auf morgen.*



**Der Spaziergang
und die Leichtigkeit
der Abstraktion**

*Ich gehe spazieren.
Bewege mich im Takt.
Ich sehe.
Atme die hellgrün riechende Luft.
Sehe genau hin.
Träume unscharf fort.
Verliere mich im Sehen und
falle weich in die Abstraktion -*

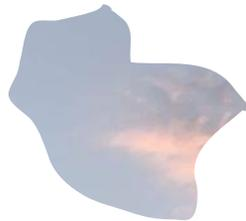



Meine persönlichen Räume der Resilienz im ersten Lockdown waren die Felder, der Himmel, die Seen und der Wald in meiner Heimatstadt in Schweden. Es war romantisch, melancholisch, einsam und heilend.



Der Mensch wird zur Wegfindung, wenn der Mangel an Kontext als Problem angesehen wird. Dies ist sowohl geografisch als auch sozial. Die Brücke wird zum Symbol für Grenzsituationen in der Welt und die Gesellschaft. In der Landschaft wird die Brücke zu etwas, das Raum mit Aktion verbindet.



01

Klara Andersson

02

Nursena Yildiz

03

Raquel Gomez Delgado

20.04.2021
Photos

These have always been problem

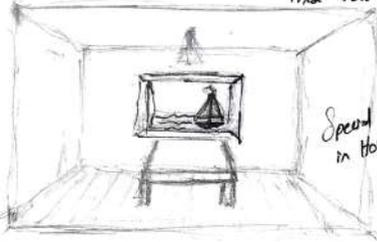

Special Area
in house



Confused

How to live?
Where to live?
How to move?
What to see?

Environment
Light Sound
Private and Social

Balcony, Kitchen, Terrace

Defined spaces:

What when you live?
You can't go to far away.
You can't go to outside

Be productive

Being together / alone

Life

Be in a harmony.

Trying out.

Discover.

Cooking.

Being extrovert at inside.

LAGERFEUER

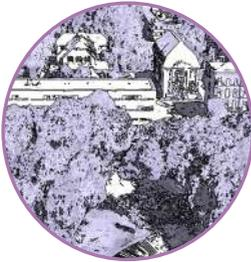

RESTAURANT

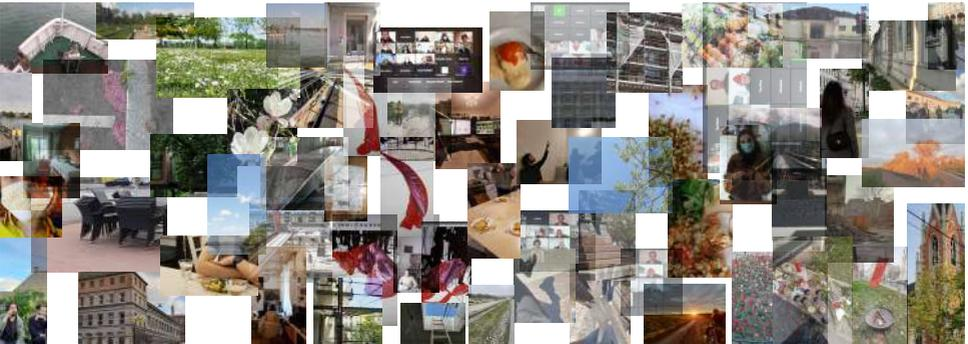

01

Ana Maria Chiriac

02

Asta Marie Hansen

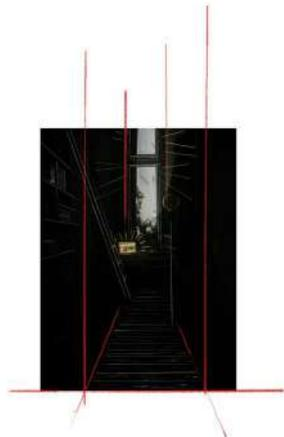
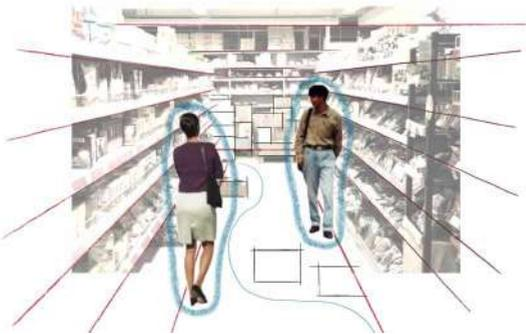
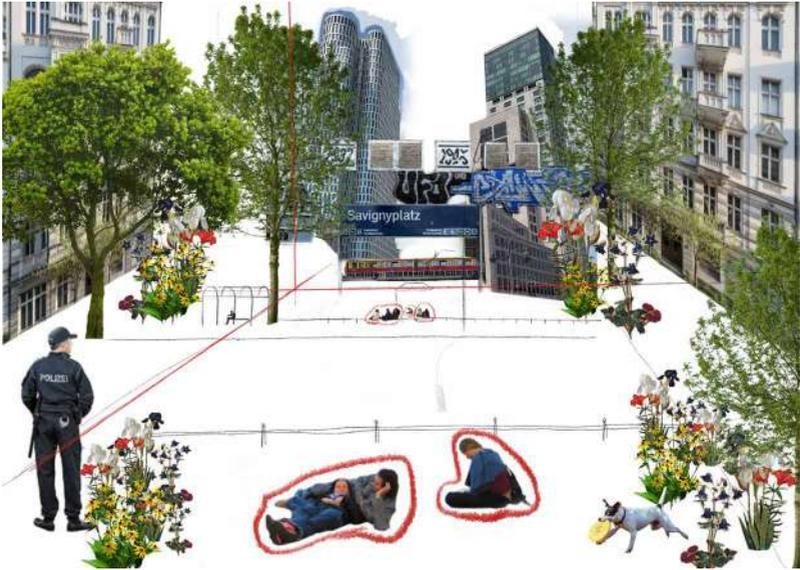

Research Mapping

Micro Scale

Meso Scale

Macro Scale

Dis/connection

From our first exercise of exploring our personal as well as collective spaces of resilience, we now move further into connecting to our site of study, Marzahn. In this second exercise, we will observe, interrogate, walk and map the micro and macro scales of the district and those in-between. The intention thereby is to understand connections between spaces, amongst individual actors and institutions as well as disconnections and boundaries, and which further or hinder processes of building resilience, and thus of an urban inclusion. For this exercise, we split up into three groups of 4-5 persons each and work in a rotational manner across the different scales over a period of four weeks.

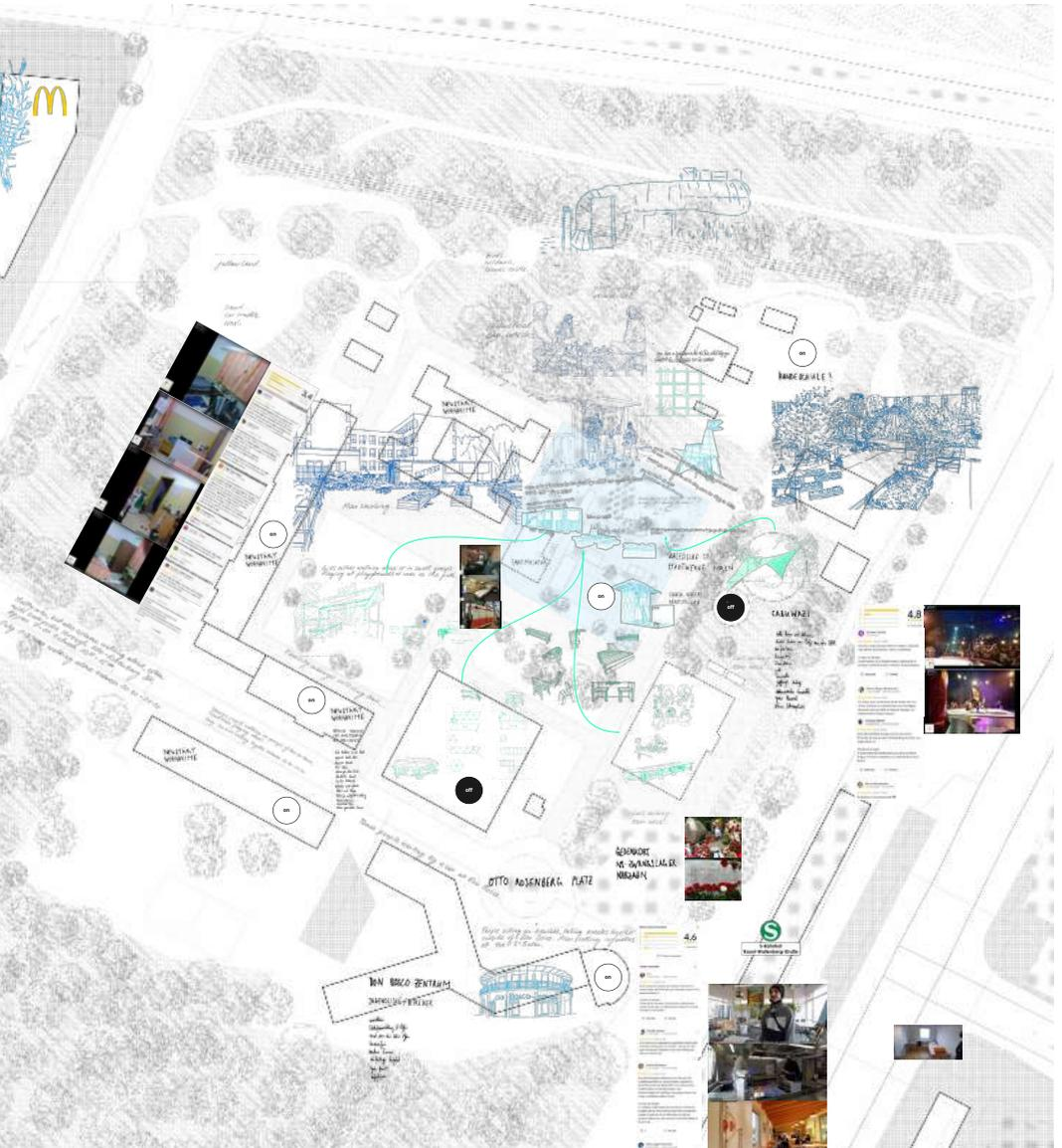



The Intermediate Scale

The group working with the intermediate scale is concerned with the immediate surroundings of the 'experimental building site': The Otto-Rosenberg square, the S-Bahn station, the residential area opposite the industrial site, the refugee camp, the shelter for homeless, the Unkenpfuhle etc. Step 1 (one week, group 1): explore and depict what forms the immediate surroundings of the experimental building site. Map the area and visualise the materiality of spaces, connections and boundaries, irritations and surprises. Do so by walking and/or taking the bike. Walk in groups and alone, listen to sounds, walk with your eyes open or closed, hold hands, get lost or try to change perspective (e.g. climb on a tree). By the end of the week, provide a base map of the immediate surrounding of the experimental building site. Note all you have experienced, including sensory explorations. Indicate for the group to follow which spaces to continue exploring in further detail. Tell them why you think these are worthwhile to connect with further.

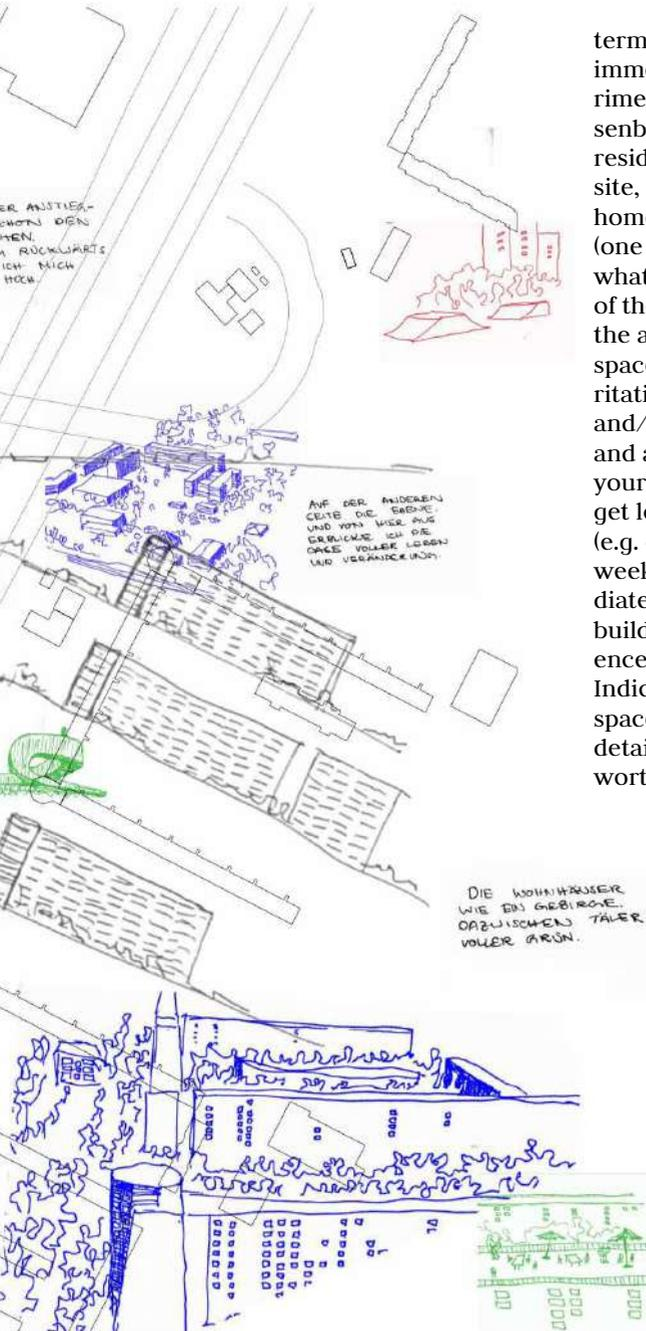

The Macro Scale

The group working with the macro scale will explore the spaces that connect the 'centre' and the 'periphery'. We will question what comprises the centre, and what the periphery and any connotations attached to the latter? Where does the periphery start / end and from whose perspective might it be central? Step 1 (one week, group 1): start from your shared space of learning, UdK, and explore different ways to get to Marzahn and onto site. Can you walk? Cycle? Take public transport? Which districts do you cross? How does the urban landscape change? Who do you meet along the way? Consider North, East, West, South approximations. Map, draw, take notes of what you see, hear, feel. Observe your emotions, consider your position as a stranger / tourist. Which spaces are you drawn to, which ones would you like to avoid? By the end of the week have a map ready with the routes you have walked, cycled, commuted along via public transport and indicate the changing urban landscapes as well as specific buildings, public spaces or so that have particularly caught your attention. The map will not be handed over to the next group but only to the third group of this macro-scale exercise.





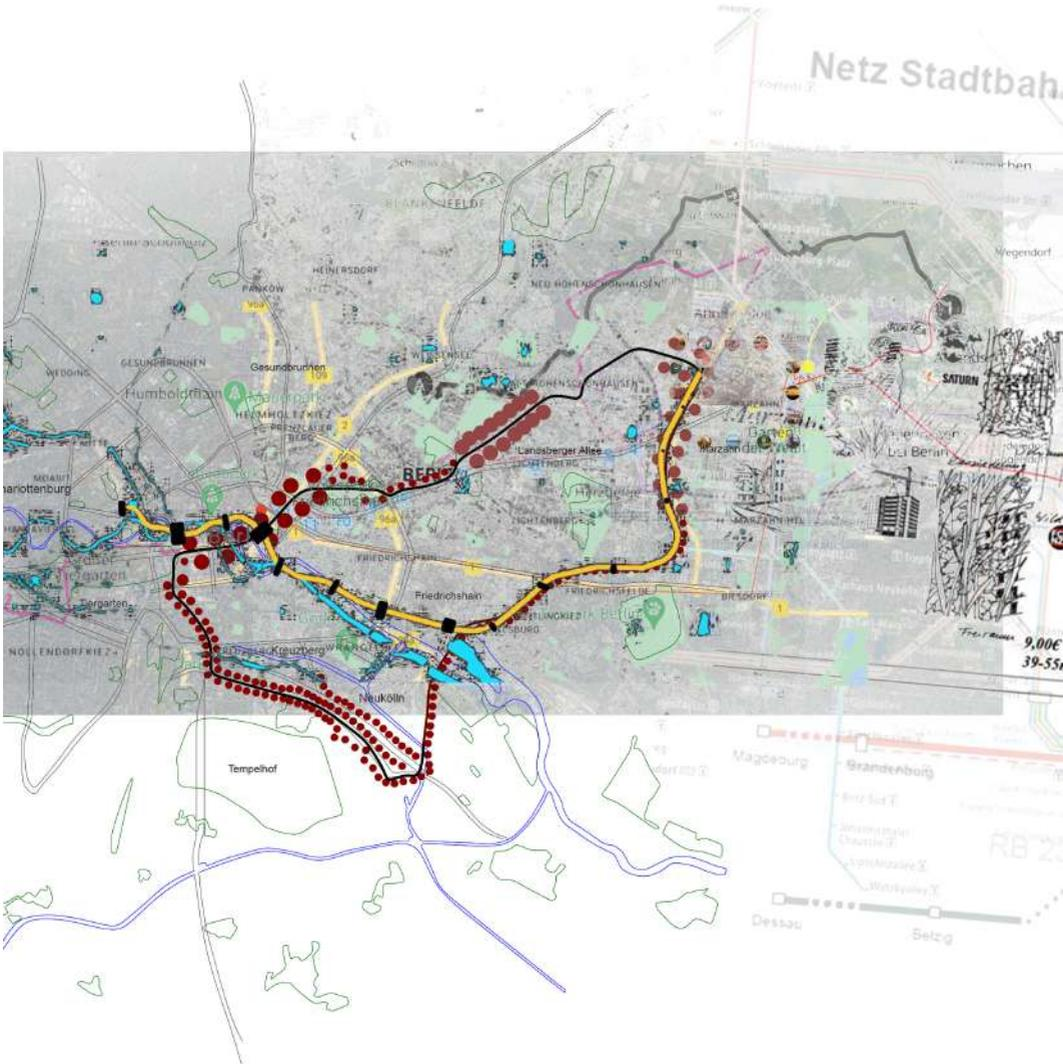

Micro Scale

Group members:

Sophie Frehse
Asta Marie Hansen
Nursena Yildi
Hanna Schmitthener
Raquel Gomez Delgado

Project „Resilience“

This project consisted of exploring a site in Marzahn, surrounded by social housing and refugee homes, we were asked to connect to the people and build structures to support the infrastructure. In this time we also organized a one week long workshop for international students.

As part of the „micro group“ we were supposed to engage with the immediate area of the `experimental building site` run by a partner institution called S27 at Otto-Rosenberg-Platz. In order to engage, we were responsible for creating a space which can be used for the studio`s participants and further on, after we leave.

In the process we were facing challenges of stability, time management, material shortages and communication barriers but were able to build a 4 by 4 meters wooden pavillion which can now be used by the visitors of the site. Especially a group of women who have been meeting almost every day, are now able to enjoy talks and food underneath the waterproof roof. We included different seating options and even a small high point for the children, which acts as a tree house.

The pavillion is build from 6 `towers` connected through diagonal and horizontal beams giving stability. Tables and benches allow the other sides to stay more open, enabling a connection between the previous meeeting and cooking area and the new room. We also added a big table to create an inviting space which can be used to eat, talk or work.



01

standing in the
shade of the cooking
area in early
may.

02

View on the container
of S27.

03

Don Bosco youth-
center

The experimental construction site and its surroundings

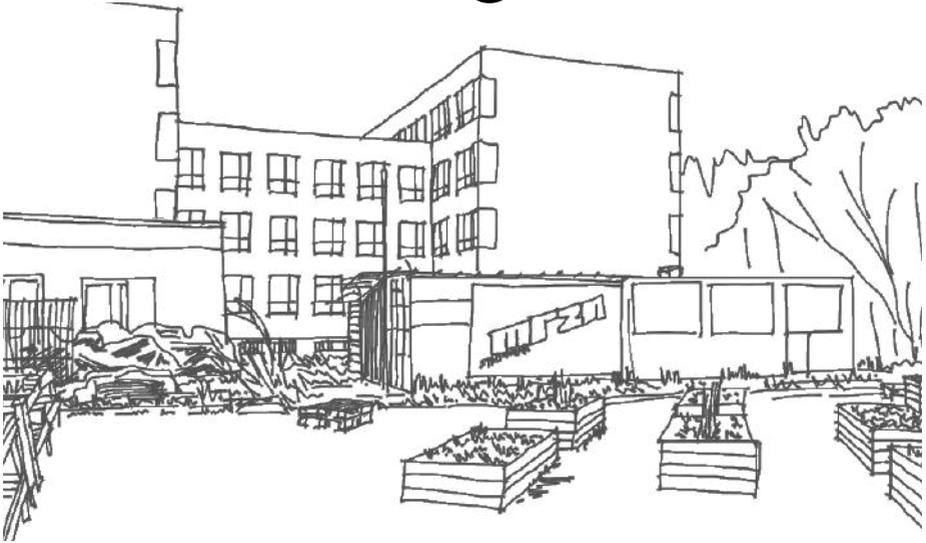

The 'Stadtwerk mrzn' is located on Otto-Rosenberg-Platz, on the eastern edge of the Marzahn district and not far from its border with the state of Brandenburg.

The square is located in the center of an industrial area and is separated from the residential area by a multi-lane street. On the square is the Don Bosco Center, a youth project with a focus on social work and youth welfare.



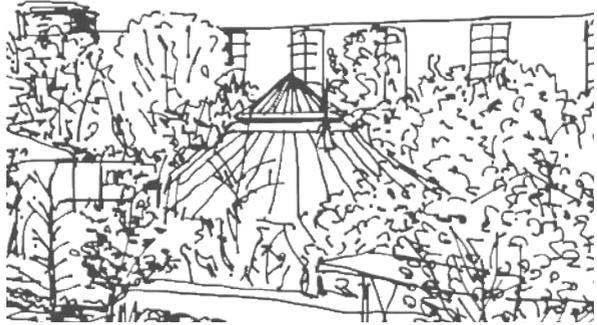

There is also a privately run residential complex for the homeless and the Circus Cabuwazi, which acts as a social hub for children and young people from socially disadvantaged backgrounds.

In 2015, an emergency shelter for refugees was opened in a former office building, which was converted into a communal shelter in the course of 2016 and today mostly houses families. With a capacity of 900 people, the accommodation is one of the largest in the district - and in the city.

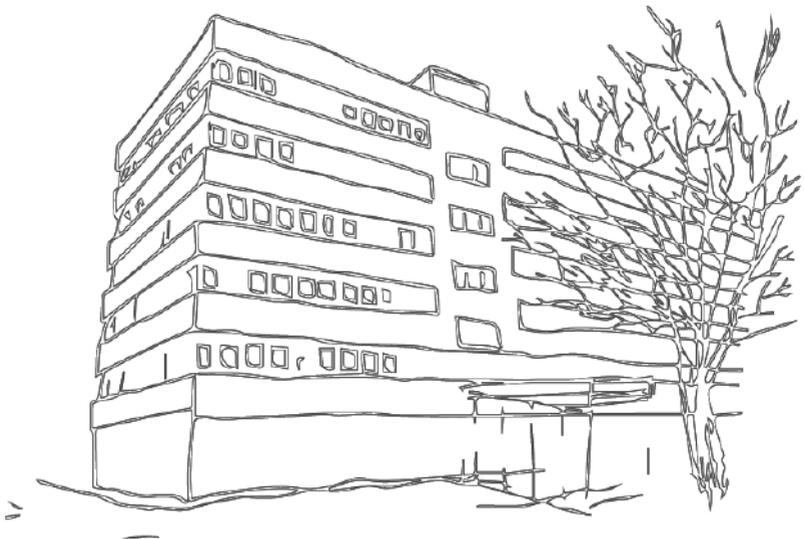



01

View on Circus
Cabuwazi

02

View on the there-
fugee housing

03

View over the
construction site
on the housing
area



01

02

Coffee table situation in april

the actors / users



Refugee

Women and Children

Young and Old People

Gardeners

Initiatives and Associations

Artisans

Architects

Artists

Federica Teti

aka Fede

Artistic co-director of Stadtwerk mrzn,
architect and graphic designer

Torsten Holger Schlopsnies

aka Todosch

Artistic co-director
of the Stadtwerk
mrzn, sculptor and performer

Luisa Durrer

Employee of Stadtwerk
mrzn and productions

Ludwig Schaible

Employee of Stadtwerk
mrzn and educator

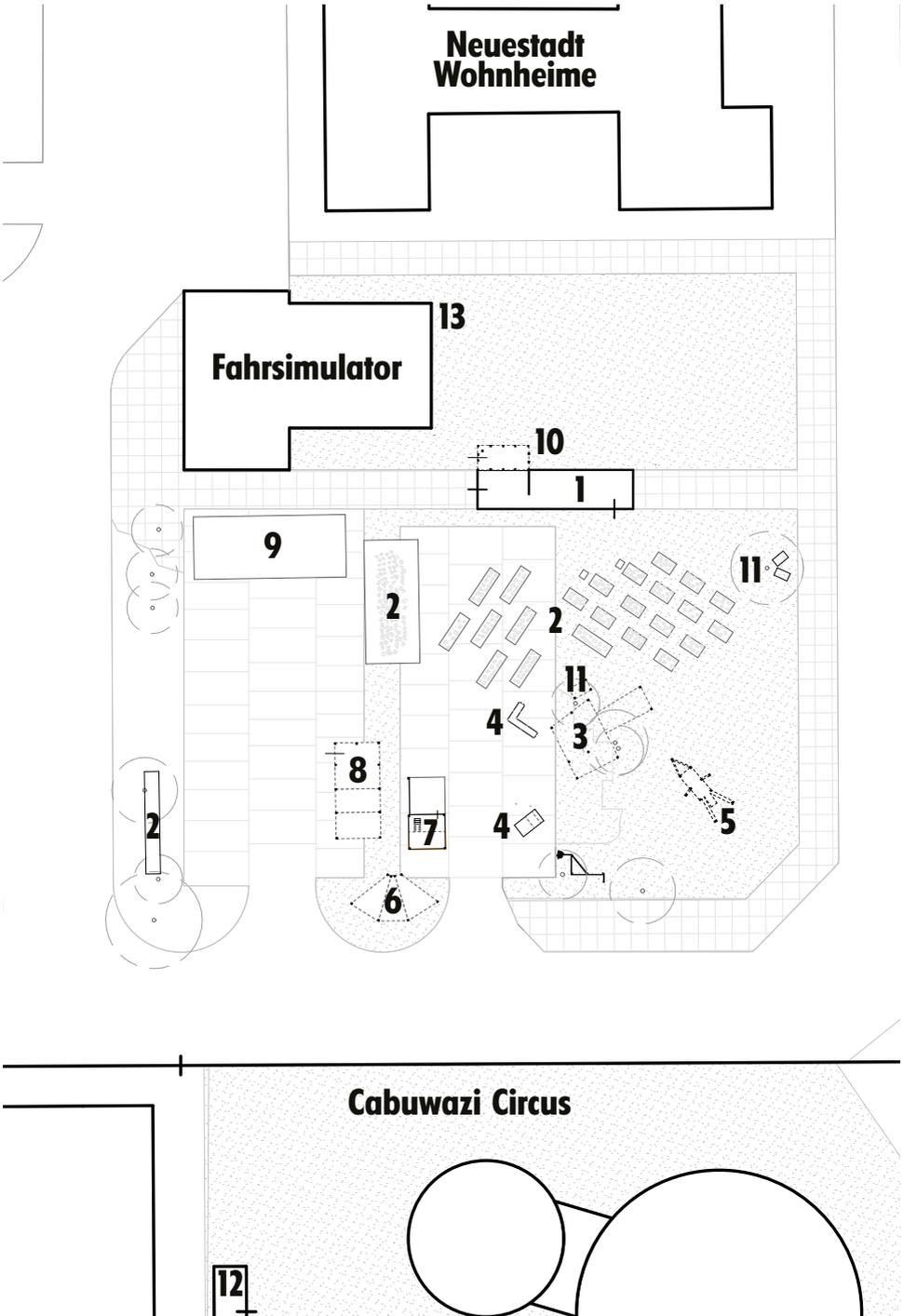

Existing transient architecture on site

- 1 Stadtwerk Marzahn container
is being used as a workshop and kitchen
- 2 Garden
- 3 Zentral wooden pergola
being used for womens cooking
nights and workshops
- 4 Open air stone stove and oven
- 5 Wooden climbing frame
for children
- 6 Wooden pergola
is under renovation
- 7 Media Tower
being used for young girls making videos
- 8 Building Space
- 9 Storage
Recycled wood material
- 10 Storage
New wood material
- 11 Soft space
place to lonely, quite
- 12 Toilets
- 13 Water





01

Children receiving
tools from the
container

02

wooden horse
sculpture serves
as the childrens
playground

In preparation for the workshop

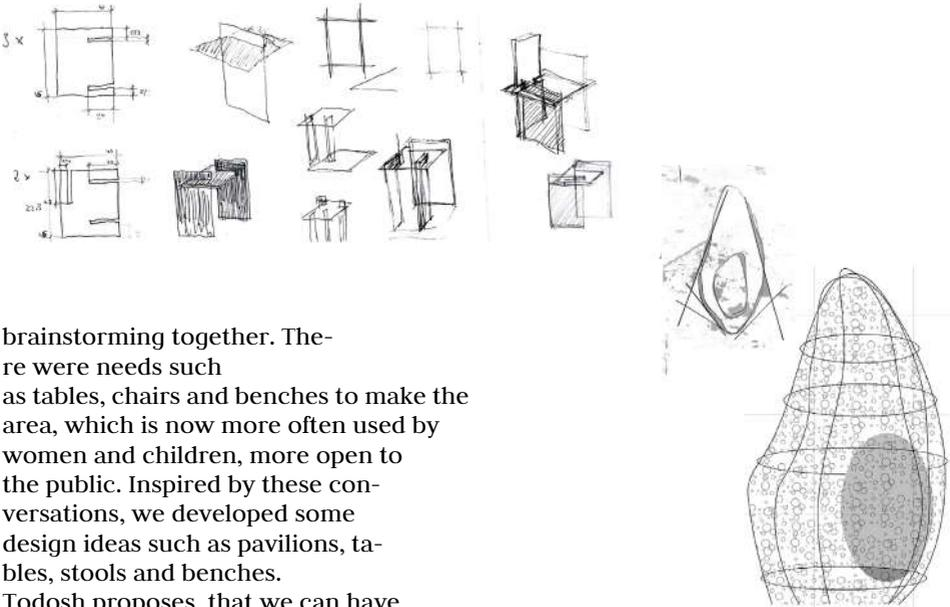

brainstorming together. There were needs such as tables, chairs and benches to make the area, which is now more often used by women and children, more open to the public. Inspired by these conversations, we developed some design ideas such as pavilions, tables, stools and benches. Todosh proposes, that we can have an improvised place to work at first and constantly improve our situation. he can also imagine that we immediately build something if we want to and feel the need. And also he added that there is a budget for construction materials. when we made a plan for design, we can talk with them and the material can be delivered.

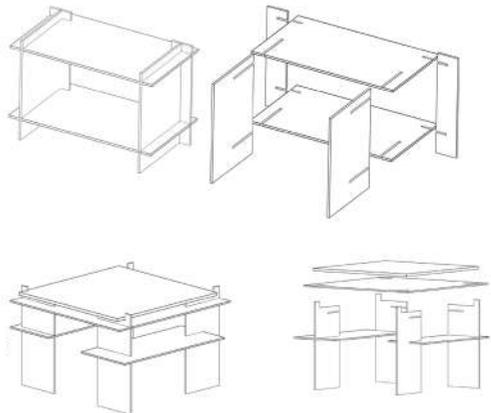



01

02

03

early sketches by
Asta Hansen and
Sophie Frehse

04

material
found on site



01

imaginary

02

03

construction
scheme of the
modular system

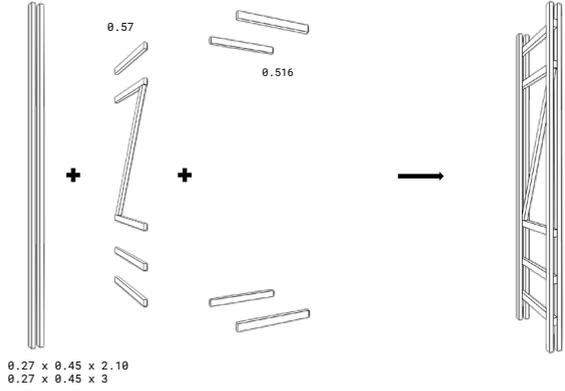

We have designed a modular system which can be used in various ways. It allows different types of assembling according to the function and can grow, change and develop over time. we wanted to create a space which can be used for communal activities, that can take place in the open.

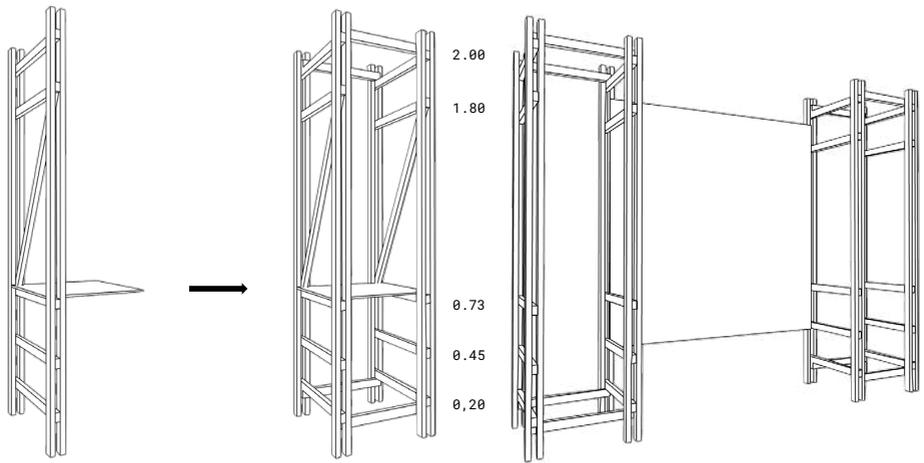

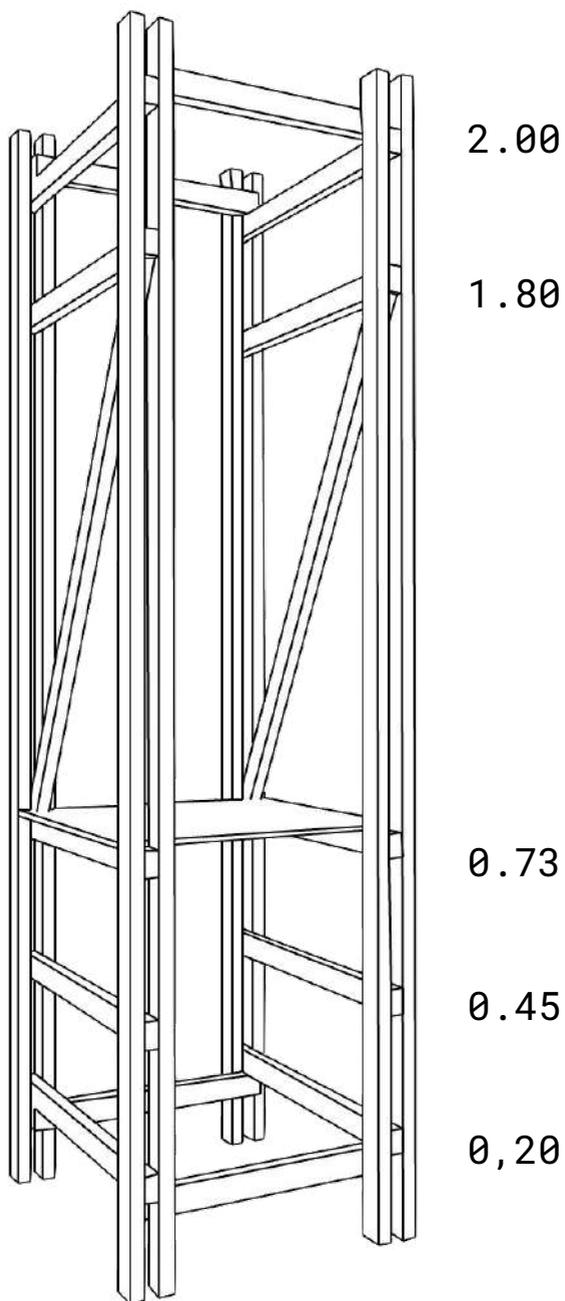



01

the system offers
different heights for
many usages

02

imaginary

Work plan

- group 1 - thinking
- group 2 - building
- group 3 - furnishing

Mission for the first group:

- Analyse the system!

What can it do?
What are the limitations?
How do we stabilize it?

- Understand the program!

Observing the needs and the location
What kind of usage is planned?
In which conditions (rain, wind, sun)?

- Make the plan!

How do we use the frames?
Where does each function go?
How do we work with the conditions?
What kind of shape/room do we create?

Mission for the second group:

- Get to know the system!

Understand the junction of verticals, horizontals and diagonals.
How do we handle the forces that will take place?
What works and what does not?

- Build!

First step: constructing the frames.
Second step: Combining the frames to create towers.
Third step: combining the towers to create a pavilion.
Fourth step: adding the roof and fixture points.



Mission for the third group:

- Furnish the pavilion!

Building a set of benches.

Building a table.

Creating a centre/heart in the pavilion.

- Build the kitchen satellite!

01

students from Udk
presenting the
intended program
for the workshop
week to the
newcomers.



The workshop



01

workshop
equipment

02

standing in the
shade of the coo-
kig area in early
may.





01

working on the
pavilion in the cold
summer rain



01

constructing the
roof of the stage



























bench
بنك

Bank
банк

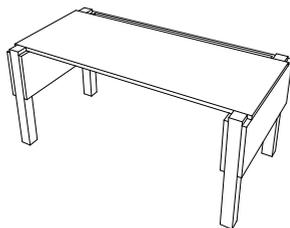

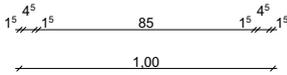
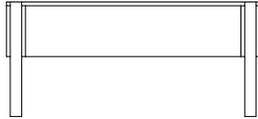
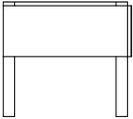

16x 45 cm h
4x 45 cm h

16x (20x50,5)
4x (20x50,5)

8x (40x100)
1x (40x100)

8x (20x100)
1x (20x100)

table
الطاولة

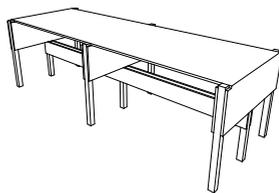

Tisch
Таблица

3x 73.5 cm h

6x 75cm h

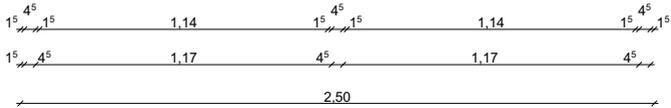
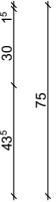
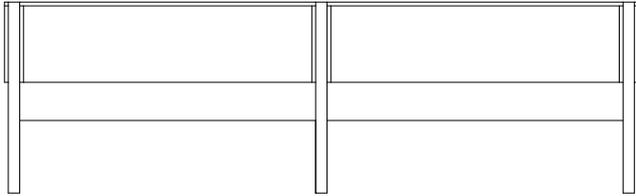
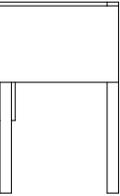
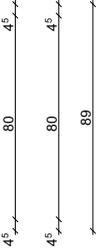
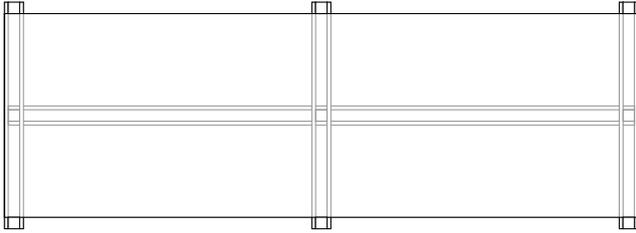

3x (30 x 89)



2x (80x250)



2x (15x247)

Bühne
сцена

stage
المسرح

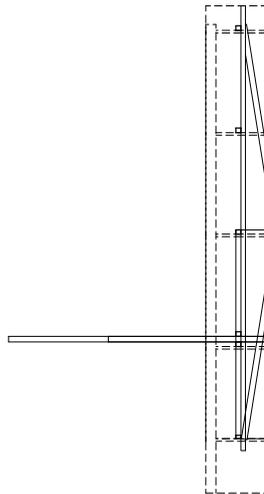

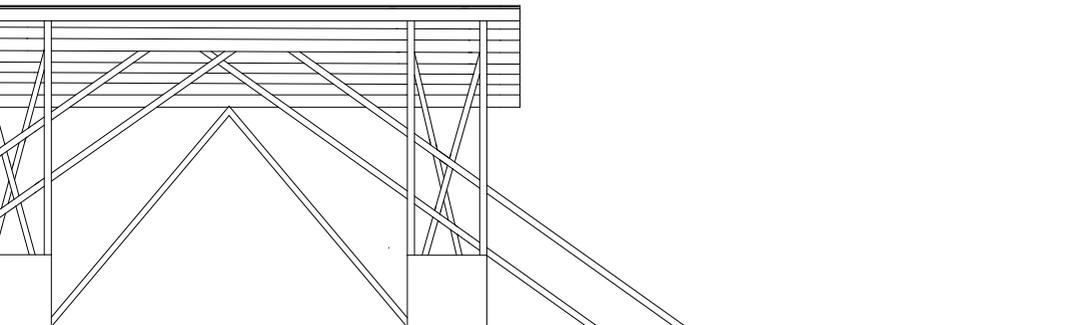
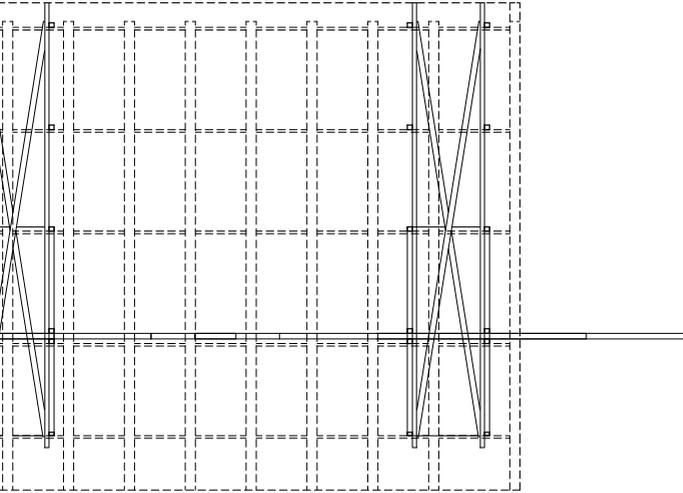

Pavillon

ПАВИЛЬОН

pavilon

جناح

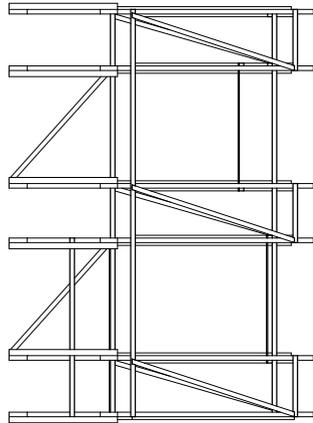

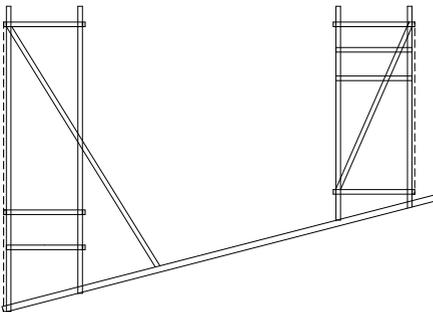
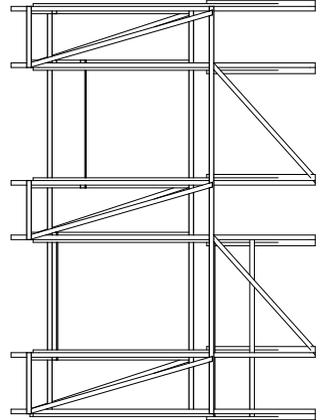
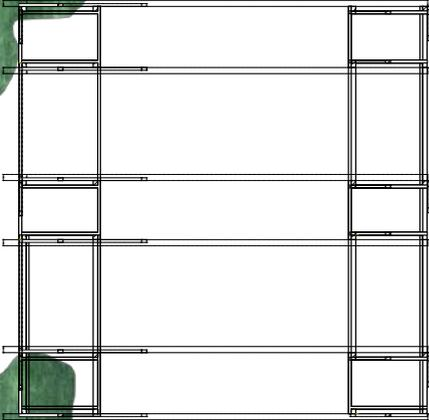
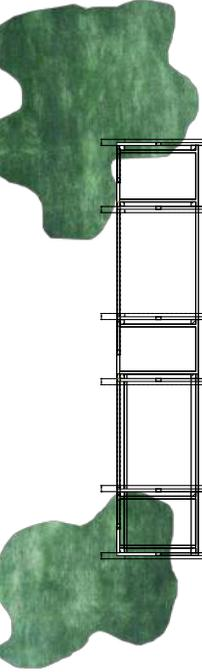
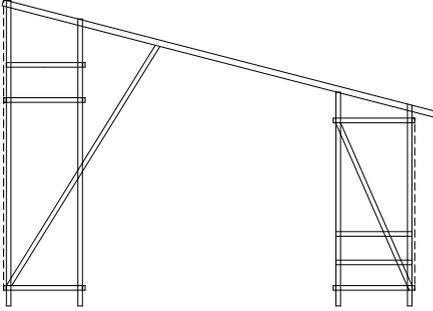

narrating the workshop







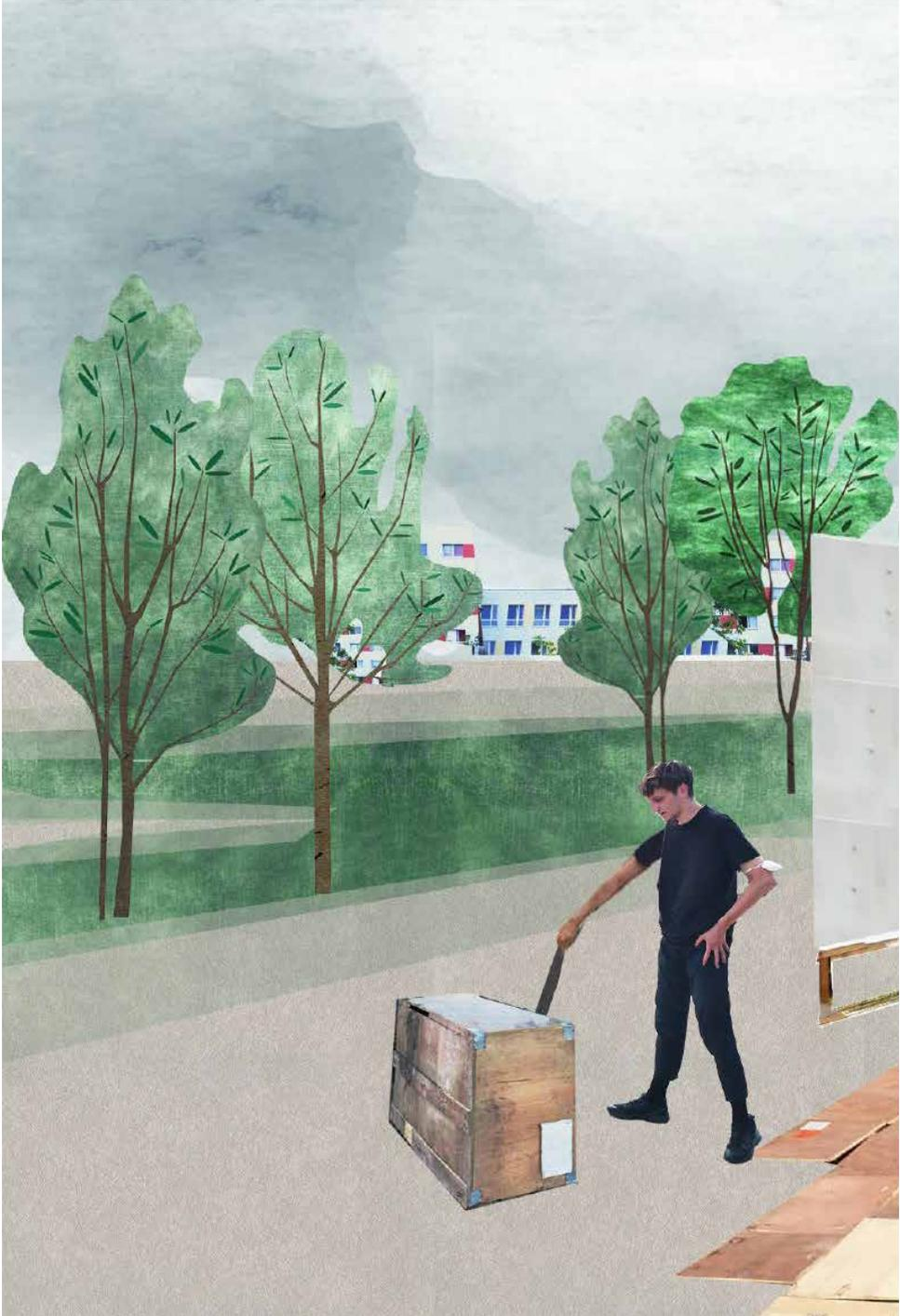











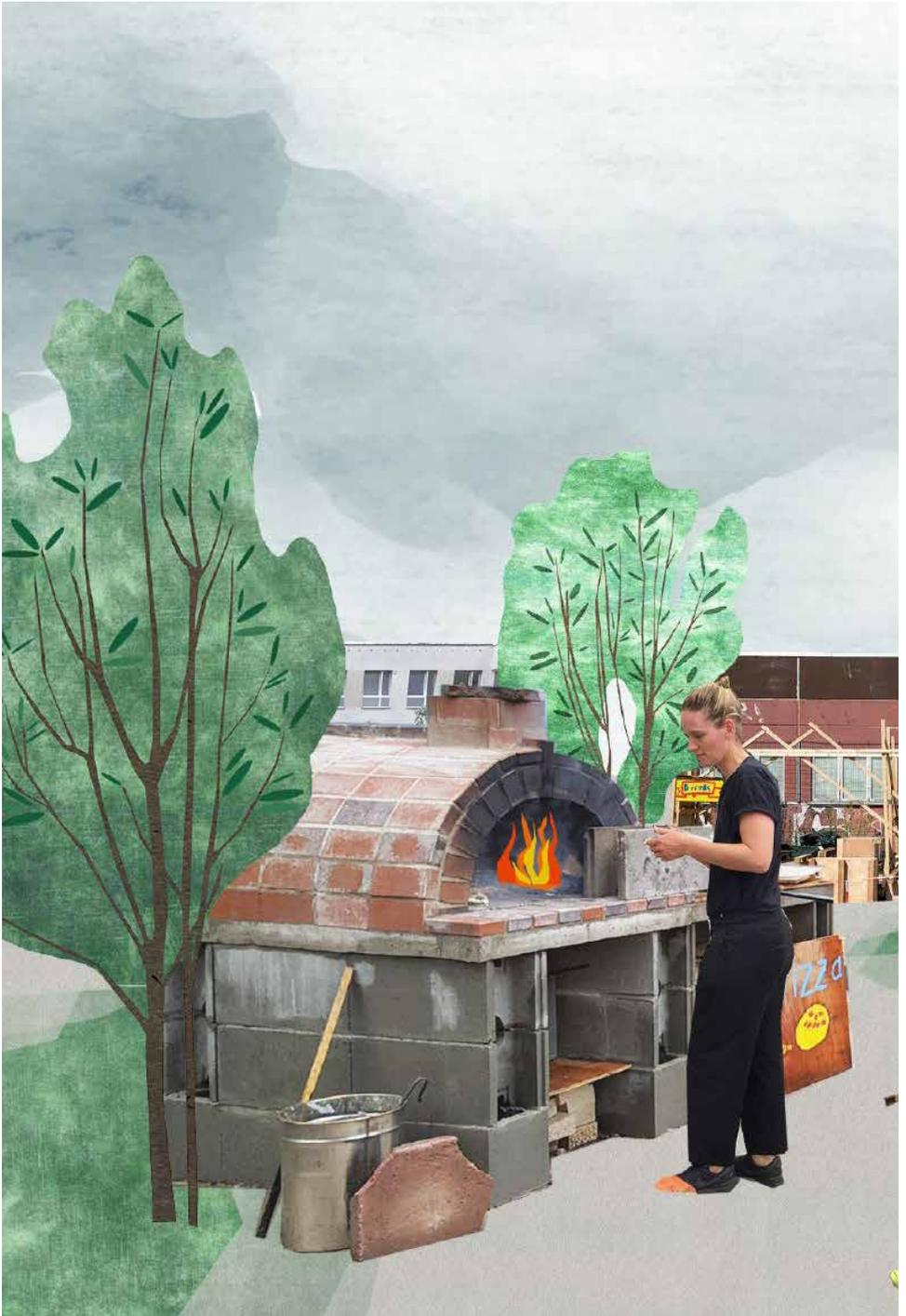

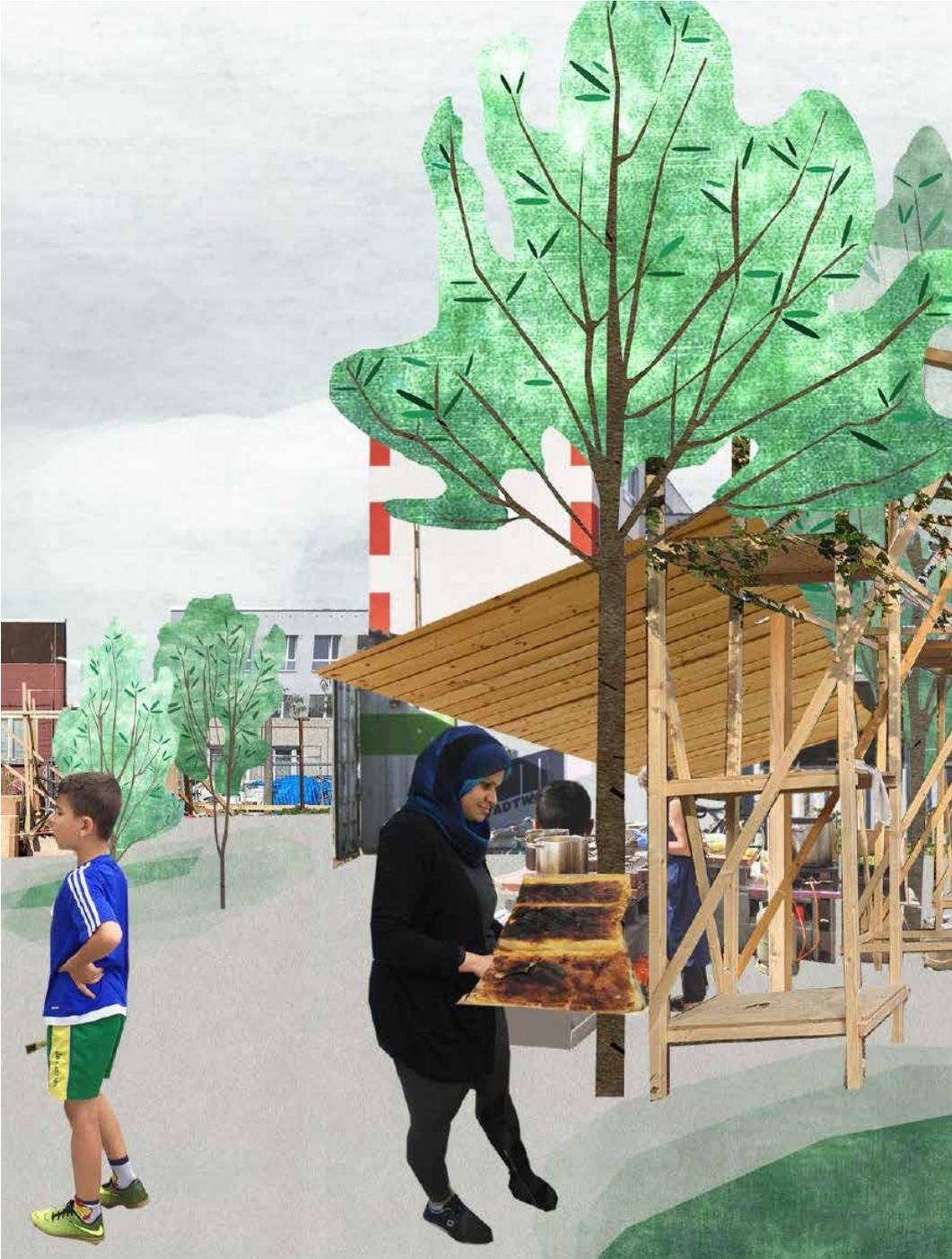



Meso Scale

Cohabitation and urban inclusion

Group members:

Klara Andersson
Ana Maria Chiriac
Eda Akartuna
Justus Barteleit
Luisa Pohlmann

Cohabitation and urban inclusion

Resilient spaces are even more important now in the current situation of the global pandemic. But also in the context of further crises - whether of ecological, social, or political nature - our resilience is increasingly demanded. And especially for so-called social “marginalized groups”, places play a role in which resilience can develop and manifest itself. In interaction with the initiative “Stadtwerke Marzahn” (mrzn), which have been operated as an “experimental building site” by the art and cultural institution Schlesische 27 since summer 2020, we were exploring how resilience can emerge in the context of migration, marginality, exclusion and beyond in the current context of the Covid-19 pandemic. Stadtwerke mrzn is located at Otto-Rosenberg-Platz, on the eastern edge of the district Marzahn, which were built during the post-war period, and were belonging to DDR at the time. The square is located in the center of an industrial area and is separated from the residential area by a multi-lane road, Märkische Allee. There is a privately run housing facility for homeless people next to the site. Also, in 2015, an emergency shelter for refugees was opened in former office buildings next to the site, which now is housing ca. 900 people, mainly families.

Background

In the semester project, some students were working on a Macro-, others on a Micro-scale. We were working on the intermediate “Meso-scale”, and our task was to connect the residential- and industrial areas of Marzahn. We wanted to create resilient spaces for the people living in the area,

but also for the surrounding nature.

The number of people living in cities and the general number of people on earth is increasing. Of all mammals on the planet, it is only four percent wild animals left. We thought that the topic of nature is something that almost everyone can relate to, independent of age and social and economical background. Further, we believe that resilient spaces are places where people from different group-belongings can meet and develop group understanding and compassion for each other. Those ideas are not only adapting to other people, but also cover our relation to non-humans (plants and animals) as well.

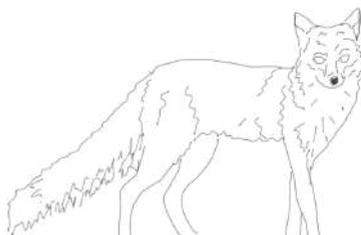

Intentions

Our idea was to develop resilience in the neighborhood through conversations and creating together. Our intentions for the project on a philosophical and utopian level were peaceful cohabitation and urban inclusion of humans and non-humans. On a different scale, the aim was to connect the excluded industrial area with the residential area. We only had one week time during the workshop and this is a process that would take much more time. But to get the process started we developed some interventions.

Interviews

With the interviews we aimed to get an understanding of people's relation to plants and their urban environment. The interviews were made randomly through spontaneous meetings in the street located in the area of Otto-Rosenberg-Platz

Every interview was started with the same opening question - if there is a plant that has accompanied them through their life. Through that simple opening question, we reached deeper topics about their thoughts and feelings towards the surrounding environment.

Storytelling

We believe in the power of storytelling and think it is a way of connecting people. We made signs and created QR codes - which people could scan and inform themselves about the local vegetation and perhaps develop interest and compassion for their surroundings.

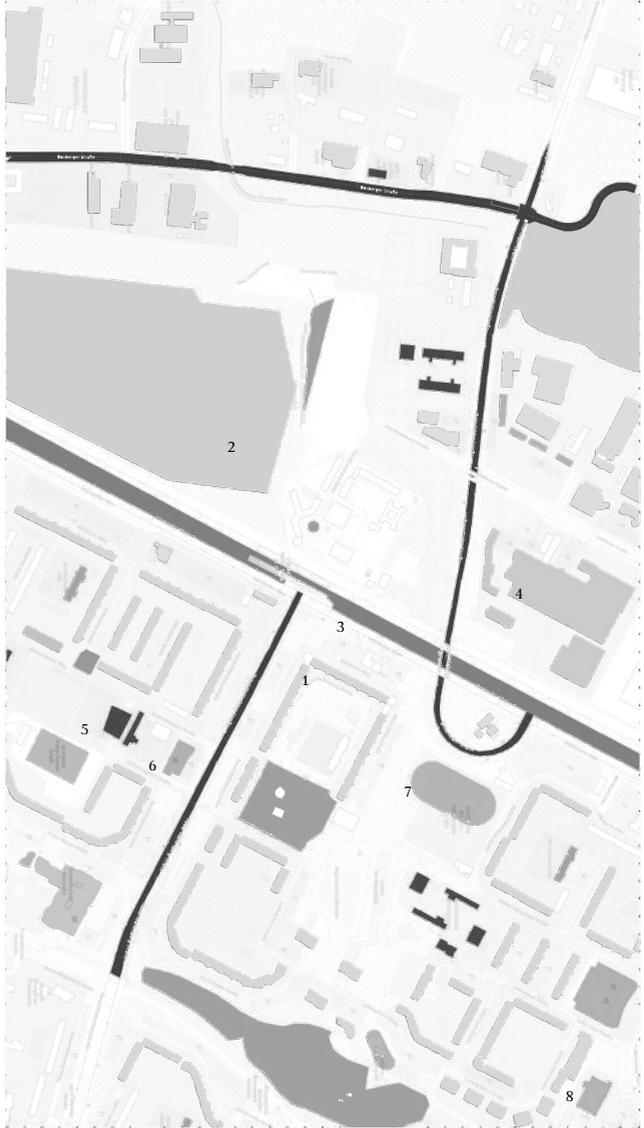

01

What is there?

- 1 Living
- 2 Green
- 3 Traffic
- 4 Industry
- 5 Education
- 6 Supermarket
- 7 Playground/Sport
- 8 Gastro



Analysis - Mapping the Area

In the first step, we started to map the area of the “experimental building site” - to get a better understanding of the space itself, the infrastructure, and the people living there. We were drawing the things we saw, and other things we could imagine. We collected thoughts and ideas - on both a utopian and „easily done“ level.

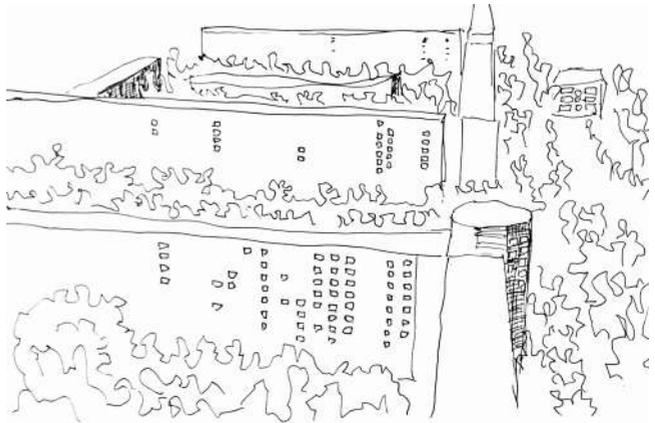

Notes

big streets, car friendly, parking lots
housing housing housing
hidden nature and parks
railway divides into two sides
Visibility and accessibility?
spaces of encounter
where do people meet?



01

How do people
perceive the area?

Male

25 years old
Donates blood twice a week (receives 25 euros each time)
Then goes to McDonald's
Also likes to visit his friend

Male

50-60 years old
Lives in Neustart Wohnheim
Goes grocery shopping at East Gate
"Frauen haben ja ihre komische Projekte"

Male

30-40 Years old
Works at Don Bosco Zentrum

Male

25-40 years old
Used to be incarcerated
Now lives at Neustart Wohnheim
Still does criminal activities on the side
Carried a pair of really nice cowboy boots

Male

20-25 years old
Lives at Don Bosco Zentrum
Drives when he goes somewhere
Stays in the nearby area most times

Female

32 years old
Tunisian-German
Born in Wolfsburg
Lives since 4 years at Neustart Wohnheim with partner
Has two kids, one she got at 18 and one at 22
One lives in a WG for children in Berlin and one lives in Bayern

Female

19 years old
Lives at Don Bosco Zentrum
Likes to hang out at playground, the döner shops or at East Gate

Male

40-50 years old
Lives at Neustart Wohnheim
Has 4 kids who live at Landsberger Allee, and he can't visit
He can't find another apartment even though he has searched for years

Male

19 years old
Lives in Ahrensfelde
Has a friend he visits in Marzahn

Male

25-35 years old

Lives at Neustart Wohnheim

Mostly just goes shopping at Edeka and doesn't do much else

Male

38 years old

Lives at Neustart Wohnheim, in Wohnheim 4

Is a music producer from home, near Mehrower Allee

Only goes outside when he goes shopping

Female

Older woman

Lives near Mehrower Allee

Walks through the graveyard, to East Gate, then through the Promenade and the Bürgerpark and then home

Male

17 years old

Lives near East Gate

Goes to a sport school in Hellersdorf

Visits friend at Don Bosco Zentrum and they hang out and play sports at the "Bolzer" in the backyard there

Male

17 years old

Lives in Ahrensfelde and goes to school in Hohenschöhausen

Likes to hang out in Neukölln

Is visiting friend with male above

Male

50-60 years old

Helps man in wheelchair living at Wohnheim with shopping

Goes with S-Bahn to Marzahn because it is cheaper

Male

19 years old

Lives at Don Bosco Zentrum

Likes to hang out at playground, the gas station or East Gate

Male

30-40 years old

Lives near Ahrensfelde

Has one daughter

Works in a kindergarten

Walks every day from Ahrensfelde to Alexanderplatz and back

Male

30-40 years old

Lives at Neustart Wohnheim

Goes grocery shopping in Neukölln

Male

26 years old

Takes the S-Bahn one stop to Marzahn to go to East Gate



01

Drawing Marzahn
Skyline

02

Drawing Bridge in
the Wuhletal

Co- habitation

Habitat

The word Lebensraum (habitat), also called biotope in the context of biology, is described in the Duden dictionary as follows: „Space, perimeter, in which someone or a community can [freely] move and develop“.

Who is someone and who is the community? The Cambridge dictionary defines habitat: „the natural environment in which an animal or plant usually lives“. National Geographic writes further: „A habitat is a place where an organism makes its home“.

The German practice and concept of Lebensraum provided justification for the German territorial expansion in Imperial and fascist Nazi Germany. According to the Italian fascists, the right to conquer living space (spazio vital) was reserved for a select few nations. The expropriation of habitat became a main goal of colonialism. We think, there is no right to claim living space!

Migration to cities

The migration of wildlife and people to cities is increasing worldwide. According to the UN population projection, at the end of this century there will be 11 billion people on earth, of which about 9 billion will live in cities. The modern age and urbanism has

caused a large part of the consumption of resources and land. Climate change and species extinction are the result.

Monocultures of the agricultural industry shaped our countryside. That is why the food supply in the cities is often better than in the countryside. At the same time animals are not hunted in the cities. The emergence of borders creates an inside and an outside. Who is excluded? Who is included? Fences and walls exclude marginalised groups as well as animals. Accessibility to places in the city always has to do with privileges.

Designing inclusive habitat

Habitat or living space is a social question. In the design of our living space, all living beings and organisms must be equally included. While planning cities, we have to think about nature and about the coexistence and needs of various human and non-human beings sharing living spaces. The aim is to build resilient, inclusive and sustainable cities and communities.

We believe in democratic participation. If everyone gets an equal vote and can stand up for his or her needs or for the needs of organisms, who can't speak to us, we can strengthen the potential of cities. We have to listen to all the voices.

Facts

2021:
7.8 billion people on earth.

2100:
11 billion people on earth.
of which 9 Billion people
will live in cities.

60% farm animals
36% people
04% wild animals

The cities are neither
designed for animals nor for nature.



Problem

We have a problem of disbalance
and social injustice on the earth.

Result

The displacement of marginalised
groups, as well as problems in terms of
class, racism and sexism, are the result.

All organism - not only people are
victims of displacement. The capi-
talist society also claims its victims
in biodiversity and nature.



Our Vision

We want all organism to
coexist in balance.

We need an inclusive city and solidarity.

We want to rethink given
hierarchies and orders.

We need a strong community and
a democratical communication.

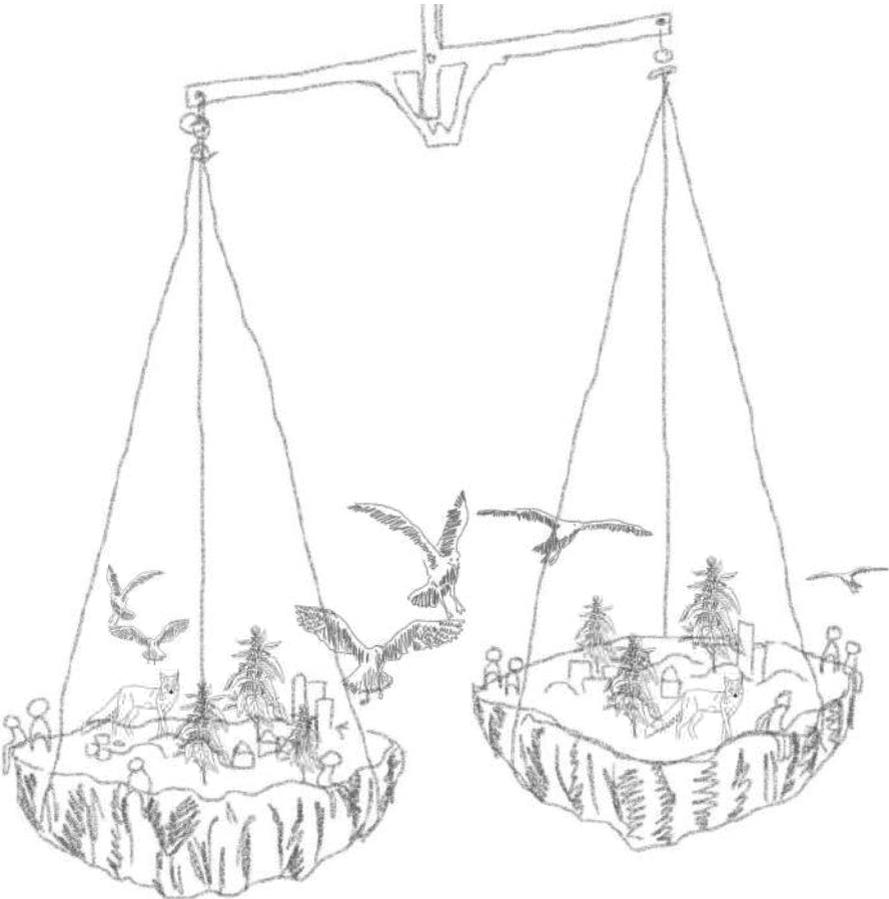

01

Utopia

Imagine how a
cohabitational city
could look like
through collages,
plans and drawings.

What we image/
ideas in the futures/
assoziations/uto-
pias?





Utopia
Coexistence





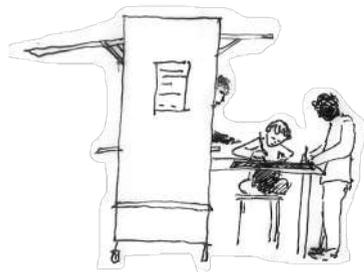

01

Exchange and interaction

02

Exploring and gathering
informations

03

Notes and drawing
thoughts and feelings

03

Leave something behind
preparing and erecting signs



Method

Habitat

We see parallels between the exclusion and oppression of animals, nature and that of marginalised groups of people.

Our aim is the inclusion of diverse groups of people and the production of collective resilience through a shared focus on and a common appreciation of the surrounding natural space.

Migration to cities

The migration of wildlife and people to cities is increasing worldwide. According to the UN population projection, at the end of this century there will be 11 billion people on earth, of which about 9 billion will live in cities. The modern age and urbanism has caused a large part of the consumption of resources and land. Climate change and species extinction are the result.

Monocultures of the agricultural industry shaped our countryside. That is why the food supply in the cities is often better than in the countryside. At the same time animals are not hunted in the cities. The emergence of borders creates an inside and an outside. Who is excluded? Who is included? Fences and walls exclude marginalised groups as well as animals. Accessibility to places in the city always has to do with privileges.

Designing inclusive habitat

Habitat or living space is a social question. In the design of our living space, all living beings and organisms must be equally included. While planning cities, we have to think about nature and about the coexistence and needs of various human and non-human beings sharing living spaces. The aim is to build resilient, inclusive and sustainable cities and communities.

We believe in democratic participation. If everyone gets an equal vote and can stand up for his or her needs or for the needs of organisms, who can't speak to us, we can strengthen the potential of cities. We have to listen to all the voices.

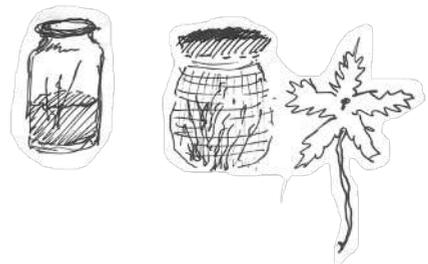

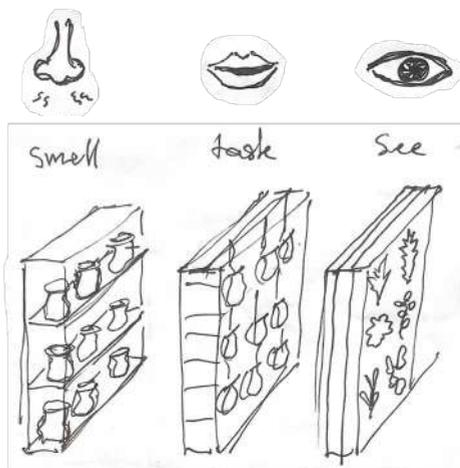

Archive of stories and senses

Learning from each other
and from the nature.

Build a mobile archive, with which we
will walk around to get in contact with
the residents and users of the surround-
ing areas. Ideas for the mobile box are:

- 1) Study of the existing flora and fauna and the creation of an archive.
- 2) Talking and asking. Noting and Drawing.
- 3) Gathering, Preparing for tea or food. Drying.
- 4) Raising awareness of the existing wildlife and its demands.
- 5) Establishing contact with the residents of Marzahn and linking them to the MRZN site
- 6) Imagining how a cohabitational city could look like.
- 7) Fun and enjoyment

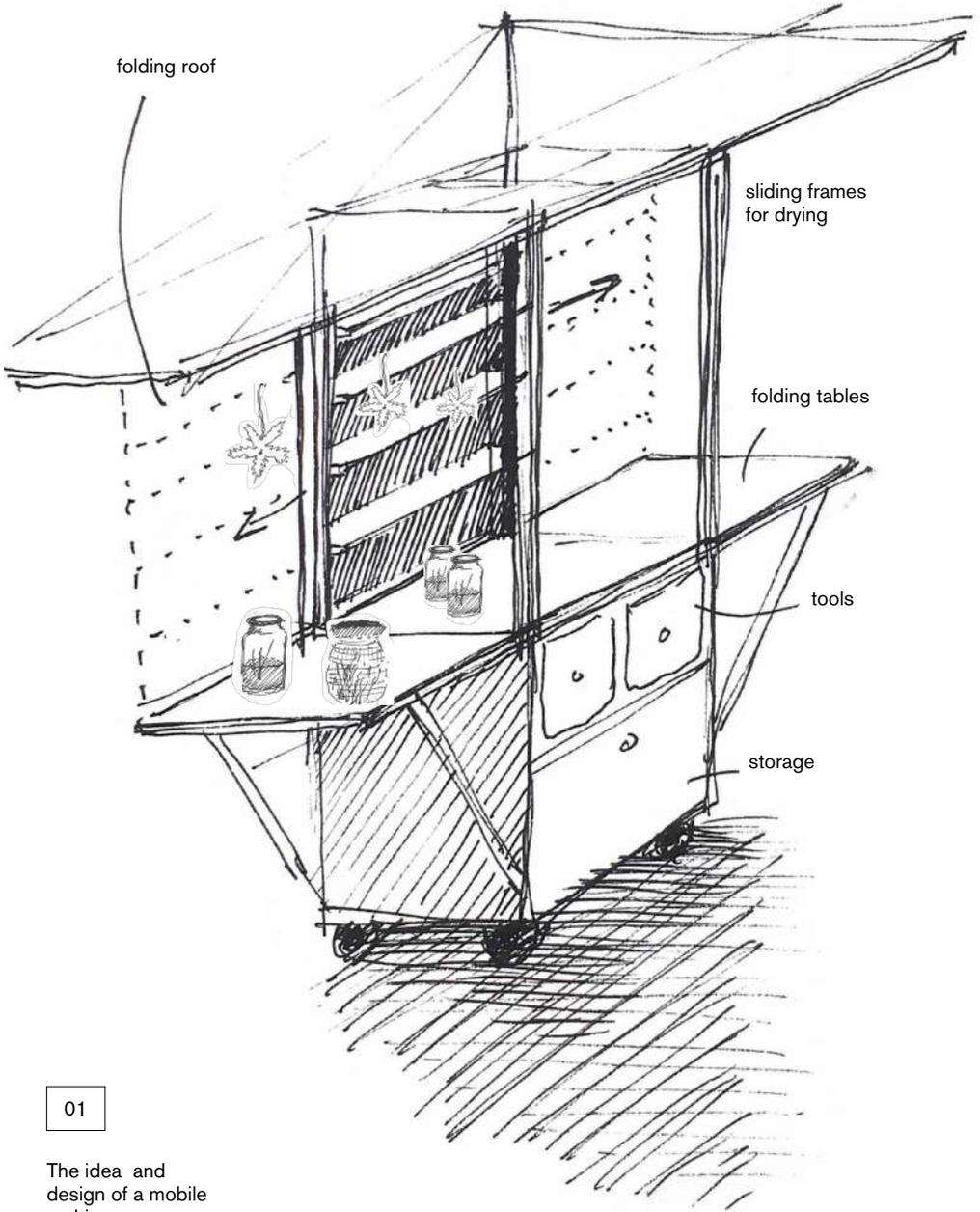

01

The idea and design of a mobile archive

Connectivity

Traffic is one of the most challenging things for the urban wild animals. Through connecting already existing green areas in the city with “green corridors” - we would create cities where the urban wild animals can move without the risk of getting killed.



01

On the trail of green spaces, wild animals and plants... Discovering green areas and their connections. What do we find there and in between?

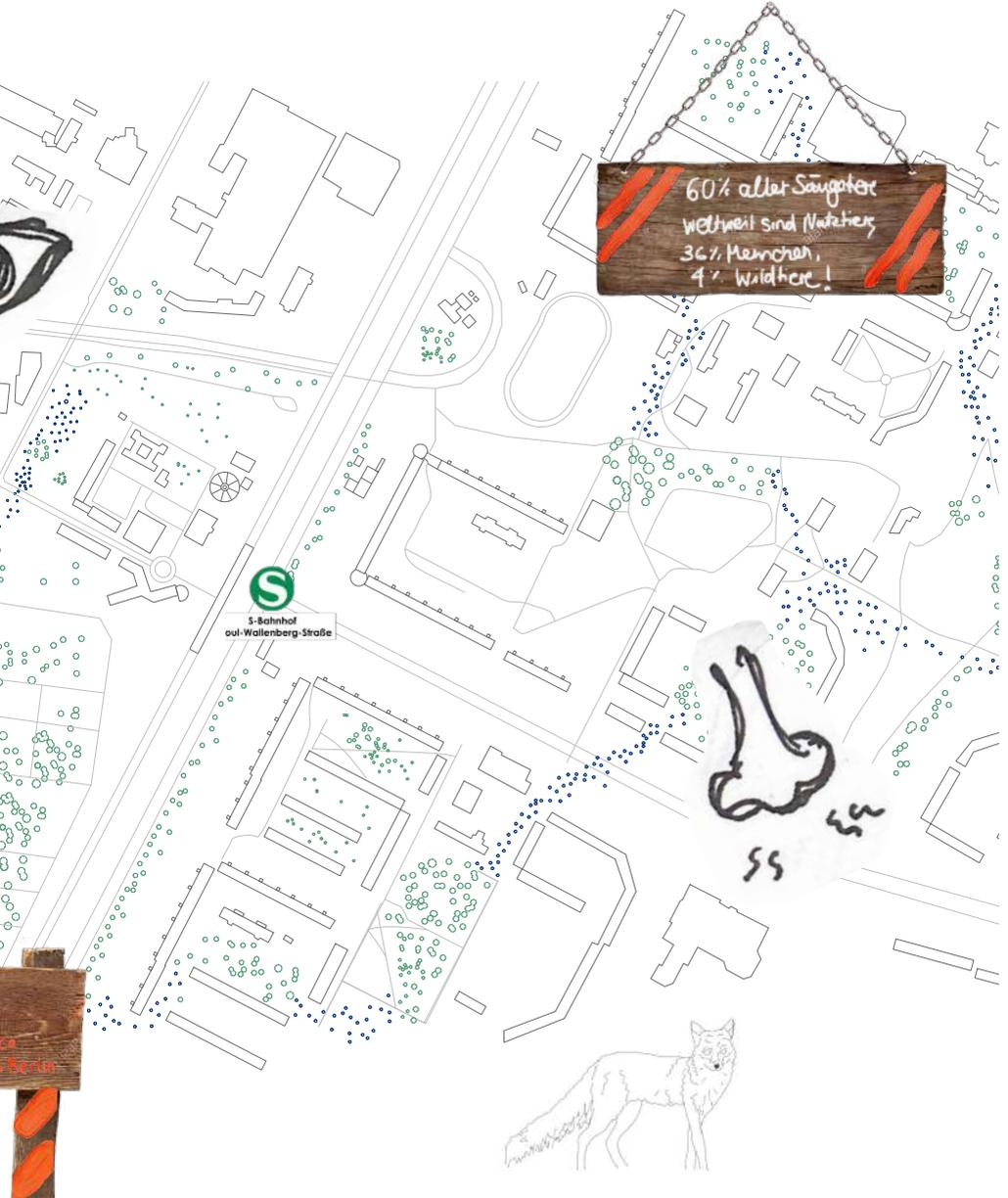



01

What a wonderful tree.

02

A normal scene at S27 in Marzahn.
Sitting outside,
drinking coffee.
It's a bit cold.

**Tentacular Thinking -
„Staying with the Trouble“ by
Donna Haraway**

„Tentacular thinking suggests the breaking of the binary through bodily practices and networks composed by trajectories, patternings and lines. The tentacular tangles the string(s) to collectively think and make kin with unknowns in storytellings that have been told and yet to come.“

“Our task is to make trouble, to stir up potent response to devastating events, as well as to settle troubled waters and rebuild quiet places.”

“Possession - property - is about reciprocity and rights of access. If I have a dog, my dog has a human.”

“Make Kin Not Babies.”

“Consciousness of exclusion through naming is acute. Identities seem contradictory, partial, and strategic.”

“We are training each other in acts of communication we barely understand. We are, constitutively, companion species.”



pionierpflanze-pioneer species
first to colonize that have been disrupted,
such as by fire

clematis- traveller's joy
"a climbing plant in ancient greek"
100 different speices



*Pioneer species of plant growing in cracks on a solidified recently erupted lava flow in Hawaii

01

Which plant did you recognise?
How do they move and grow?
Picture them.
What do you know about them?
Can you see one right now?

echter hopfen-humulus lupulus
2,5m
blooming green white flowers July-September

sanddorn-hippophae rhamnoid
used in medicine food and co
2-4m

wild cherries

ruderalpflanze-ruderal species

first to colonize disturbed lands.



les-Fasan(en)beer(e)
smetics (vitamins)

königskerzen-verbascum

20-150 cm, blooming in june-august
medicine

wasp

they had a wasp nest last year
next to the door of the container

rat, mouse

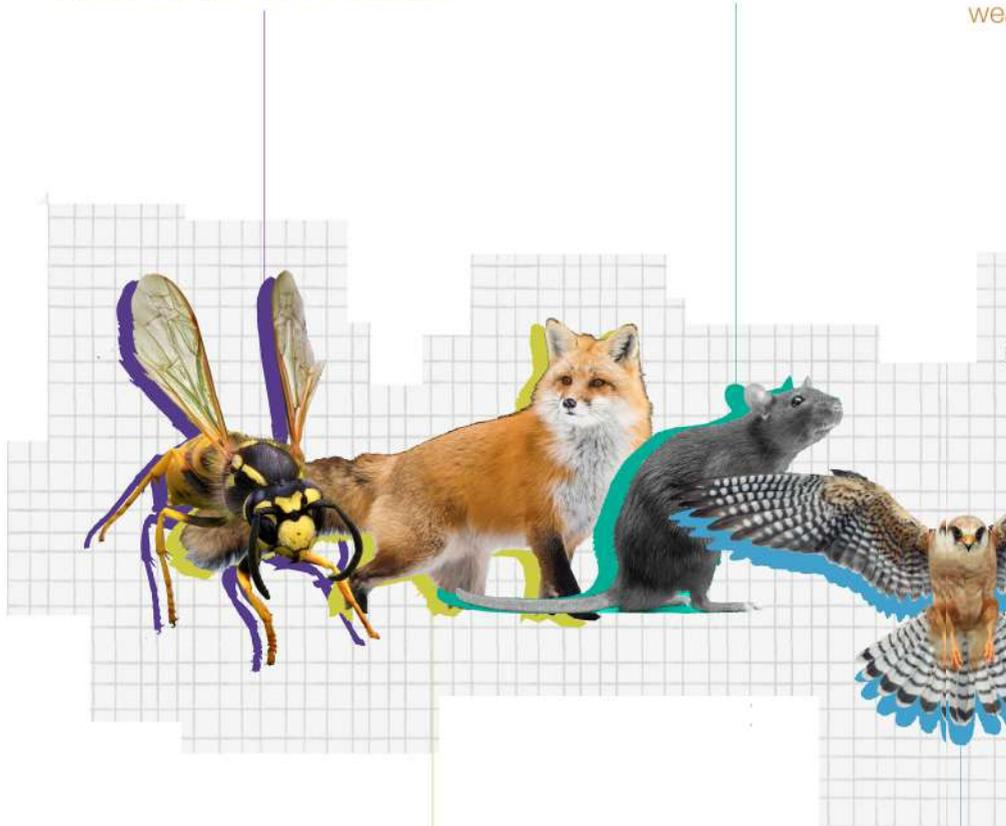

01

Which animal did you recognise?
Where do they move and live?
Picture them.
What do you know about them?
Can you see one right now?

fox

there are more fox dense
in the city than in the forest

fallcon

harder-mustelidae
sables, badgers, minks

wild bees

blindschleiche-slow worm

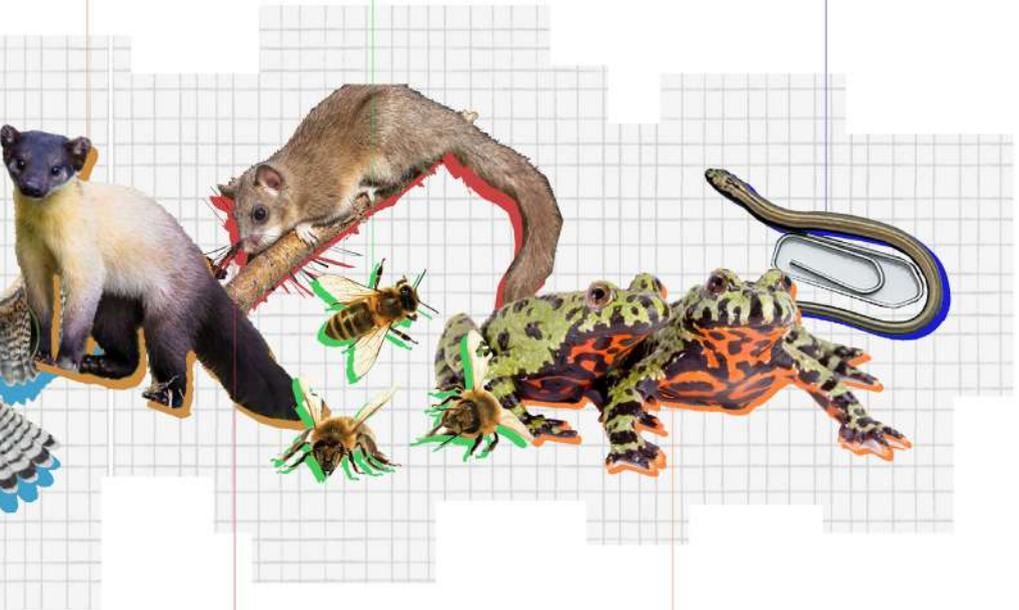

siebenschläfer
edible dormouse

die unken (bombina)-fire bellied toad
became extinct



Workshop Action

Mobile Archive

We were building a Mobile Archive from only recycled material together with the kids from the refugee shelter. We planned to use it as a tool - to get in contact with people in the area and connect different groups. We also used it as an archive for stories and other information we were collecting and sharing with the community. We also used the Mobile Archive to demonstrate physical exclusion in the public space. On the industrial side of Märkische Allee, on which the Experimental building site is located there is only a stair - nobody with a baby trolley or someone in a wheelchair can access on that side. This is something we believe has to be changed.

You are surrounded by human, plants and animals. You can invite people to join you at the mobile archive. Ask them what they know, see,... tell them what you know, see,...

What story comes into the head?

Document your knowledge and the new story. At the end of the route, you return to the site with a story.

What does the plant/ animal feel, look, (taste) and smell like?

What activity or thought does the plant/animal inspire?

01

Building & Recycling
the mobile Archive

02

Good to have some
helping hands!





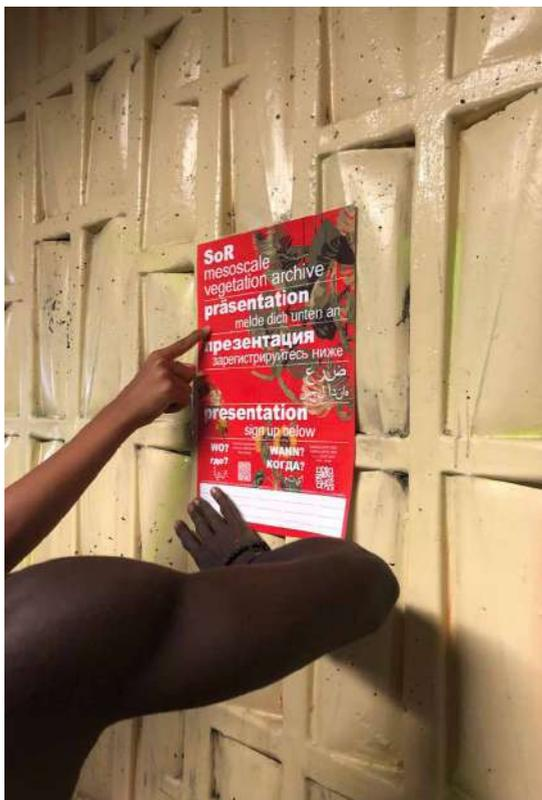



01

QR Code and
Posters

02

Plant Sheets &
Questions Memory
Map









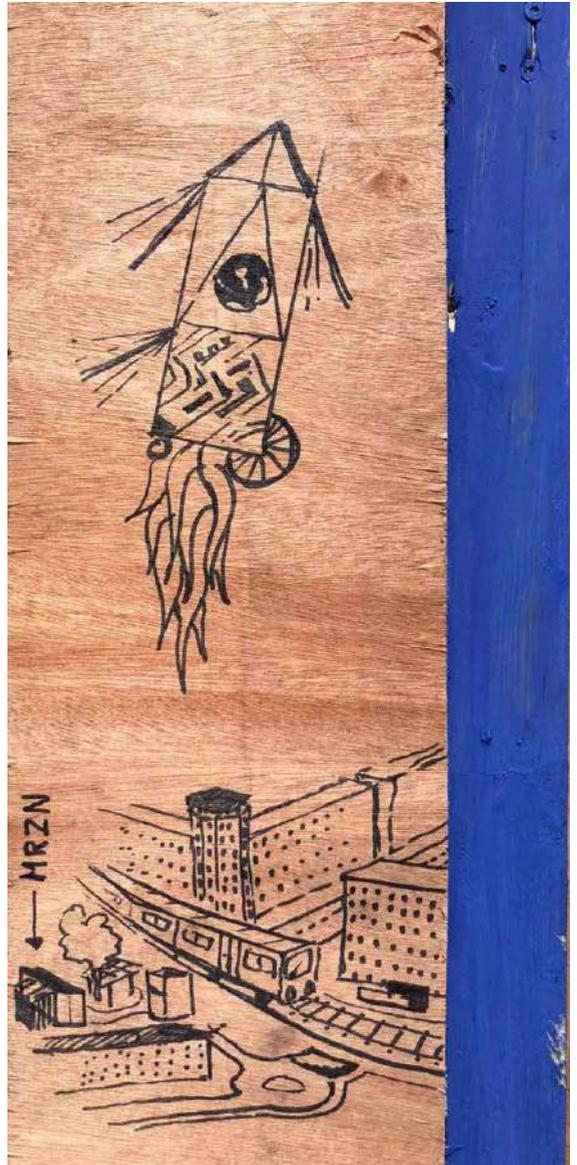

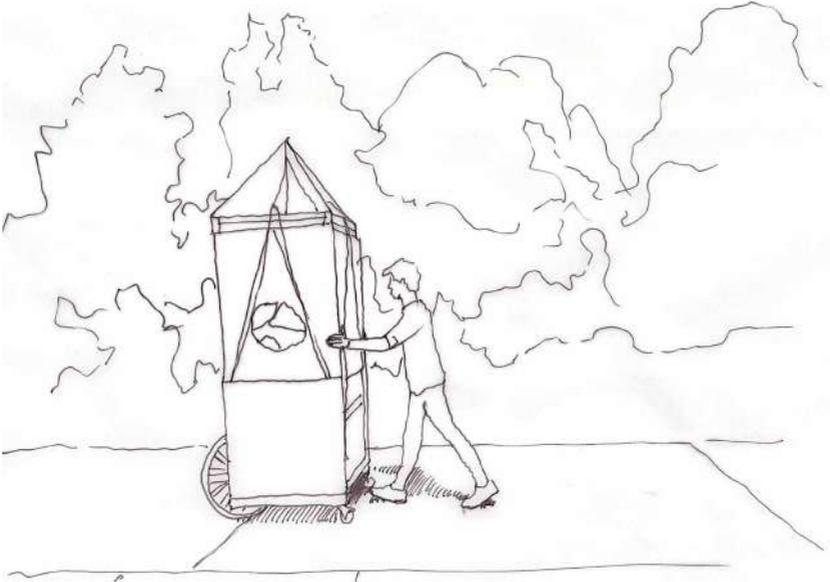

01

Mobile Archive in
Action

02

Route and Mapping
of Green Areas





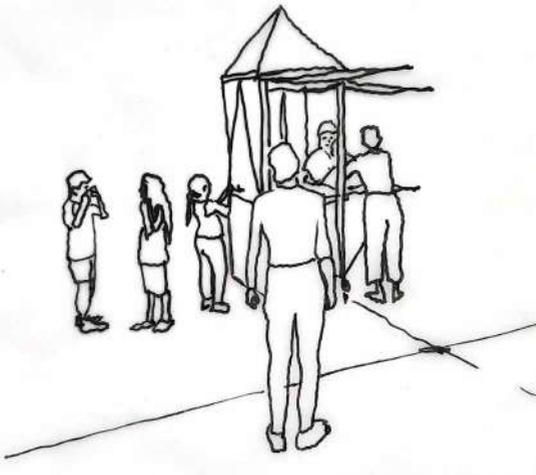



01

Putting up Signs

02

More Signs!

03

Mobile archive of
Plants & Interviews





01

Putting up Signs

02

More Signs!

03

Mobile archive of
Plants & Interviews













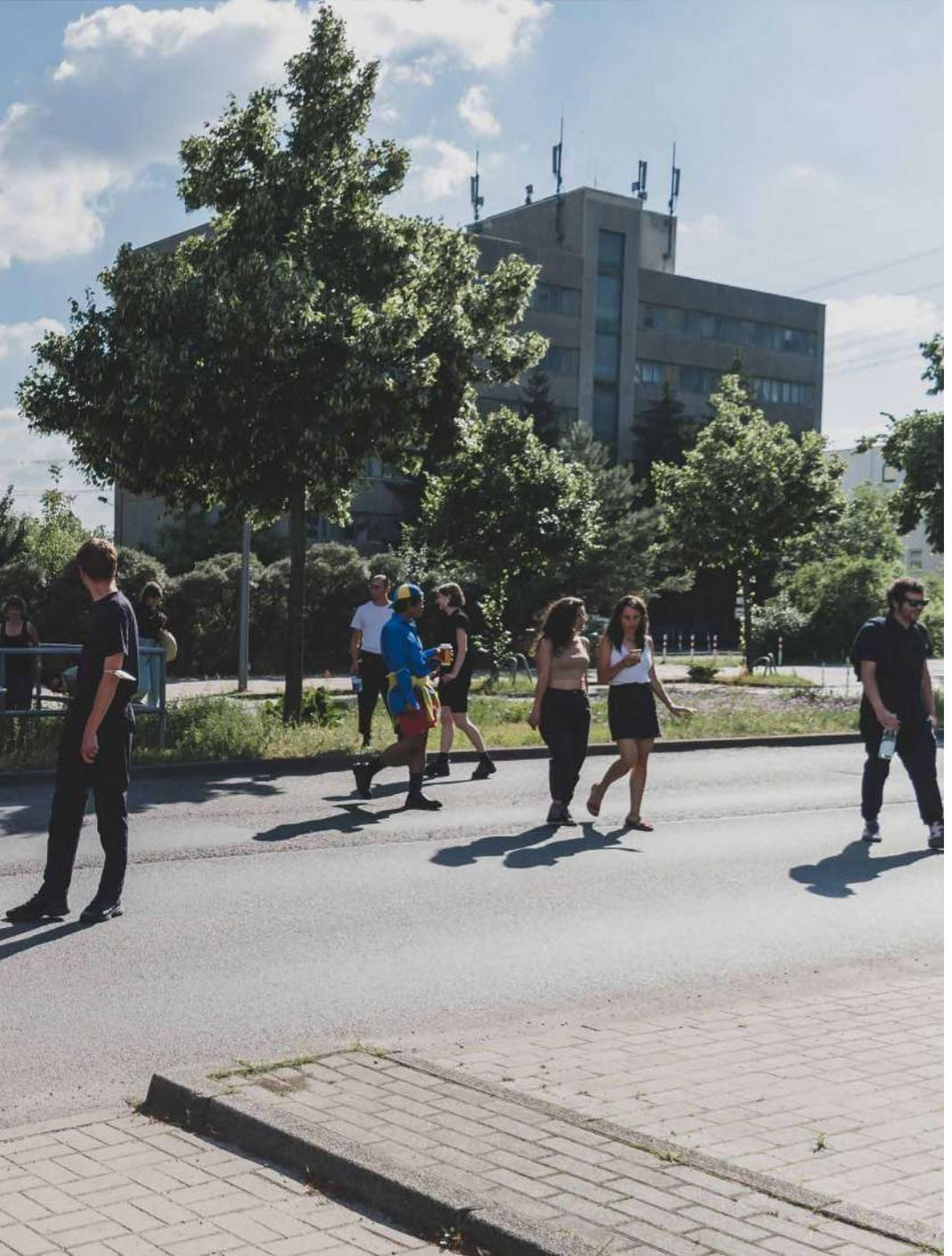

Interviews

1. Pit – Tomatenpflanze

K: Gibt es irgendwelche Pflanzen, die für dich besonders sind? Vielleicht aus der Kindheit?

P: Nee, da fallen mir nicht viele ein, aber was ich gerne privat mache, ist, selber Pflanzen anzupflanzen und zu schauen, wie sie wachsen. Daran habe ich viel Freude. Also zum Beispiel eine Tomatenpflanze aus dem Samen selber sähen und wenn dann irgendetwas daraus wird, finde ich es schon sehr schön. Es ist ein schönes Gefühl was gepflanzt zu haben, was man später auch essen kann. Aber sonst sind Pflanzen Lebensspender, die Sauerstoff produzieren. Das war es aber auch schon für mich was die Pflanzen betrifft. Es gibt auch bestimmt Exemplare die schön aussehen, mit großen Blättern und so, da ist eher die Freude des Anblicks.

K: Ja, das ist ja auch das, was den Sommer so besonders macht.

P: Ja, es ist wirklich schöner, wenn alles ein bisschen grüner draußen ist, anstatt nur grau, wie im Winter halt.

K: Gibt es irgendwelche Pflanzen, wo du sagen würdest, dass Du nicht so gerne deinen Sommer ohne diese Pflanze verbringen möchtest?

P: Da fällt mir gerade keine ein, ich mag aber Brennnesseln nicht so gerne, wenn ich da reinfallen würde zum Beispiel. Ich weiß, dass man daraus Salate und

so machen kann, aber damit habe ich auch nicht so viel Erfahrung gesammelt. Eine Pflanze, die meinen Tag verschönert, fällt mir gerade nicht ein.

K: Und Wildkräuter?

P: Nee eigentlich auch nichts. Partizipien essen ist schon was Schönes, aber.....

K: Aber du meinstest, dass du Tomaten zuhause anpflanzt?

P: Ja, sowas habe ich schon zuhause, da freut man sich, wenn was aus der Pflanze geworden ist, wenn dann mal eine Tomaten dranhängt und wenn man die dann am Ende auch verwerten kann. Das ist okay, es ist schön. Ich kann mir selber auch vorstellen, dass ich irgendwann in der Zukunft auch ein bisschen öfter im Garten arbeite, aber letzten Endes sind sie zum essen da.

K: Wo ist dein Zuhause?

P: Es ist hier um die Ecke.

K: Dort befindet sich auch der Garten der Begegnung, wo man Urban Gardening betreiben kann.

P: Da war ich noch nie, die stellen aber gerne Pflanzen draußen hin, von denen man auch welche mit nach Hause nehmen kann. Man kann auch selber welche dazu stellen. Zum Beispiel, wenn man eigene Tomatenpflanzen gezogen hat, und zu viele davon hat.

K: Ja, dieses teilen ist schön.

P: Genau.

K: Aber was ist mit dem Ort hier?

P: Speziell ist, dass es eine Kinder und Jugend Freizeiteinrichtung ist.

Wir haben sie uns begrünen lassen,
da wir alle nicht so die Gärtner sind.
Ansonsten pflegen wir sie selber.

**K: Also du bist eine von den Mitarbei-
ter_innen?**

P: Ja, ich bin schon seit 1992 hier. Der
Platz existiert seit 96, also wir sind
hier beim Circus Kubowski. Das Ge-
lände hier vorne bei der orangenen
Halle ist neu gestaltet worden, aber da
waren Fachleute am Werk. Alles was
hier hintern ist, wurde von uns selber
gepflanzt. Das waren keine Gärtner.

**K: Schön! Das heißt, dass der Ort
hier schon schöne Gefühle für dich
aufruft?**

J: Ja, kann man sagen. Im Sommer
arbeite ich hier voll gerne, auch weil
es ein schönes Gelände ist. Das hören
wir auch immer von Anderen, dass
das Gelände hier schön eingerich-
tet und begrünt ist. Es ist auch rela-
tiv gut aufgeräumt und eben grün.

**K: Und im Marzahn fühlst du dich
auch zu Hause?**

J: Ja, ich bin auch hier groß geworden.

K: Schön.

J: Ich bin auch hier geboren, nicht
in Marzahn, aber in Lichtenberg.

2. Anonym – Gurke

**K: Hast du eine Beziehung zu den
Pflanzen in der Umgebung?**

U: Nicht wirklich, hier sind nicht so
viele. Innerhalb von Berlin gibt es ein
paar Orte, wie den Tierpark oder so,
da sind viele, aber nicht wirklich.

**K: Gibt es irgendwelche Pflanzen, die
dir wichtig sind oder die Du im Alltags-
benutzt?**

U: Die einzigen, die mir spontan ein-
fällt, wäre die Aloe Vera, aber sonst
nicht wirklich...Doch bei meinen El-
tern haben wir Gurken und Toma-
ten nicht gekauft, die haben wir aus
unserem eigenen Garten gegessen.
Aber das ist außerhalb von Berlin.

**K: Okay, außerhalb von Berlin. Ist dort
dein Zuhause oder hier?**

U: Hier.

K: Wie ist dein Gefühl zu diesem Ort?

U: Es kommt darauf an, manchmal trifft
man komische Leute, aber auch nette.

K: Aber fühlst du dich hier zu Hause?

U: Ja..

3. Yvonne – Hibiskus

K: Kennst du irgendwelche Pflanzen aus der Gegend hier?

Y: Nicht wirklich.

K: Gibt es eine Pflanze, die Du in deinem Alltag verwendest oder eine an die Du dich aus deiner Kindheit erinnerst, die wichtig für dich war?

Y: Hibiskus mag ich gerne. Erdbeeren aus dem Garten mag ich auch oder vom Balkon. Gurken auch... Und Paprika. Und Wassermelone.

K: Okay, also kannst du die auf deinem Balkon pflanzen?

Y: Ich versuche es, er ist belastet - also wie ein Gewächshaus...Er liebt auch Wassermelone (zeigt auf ihren Hund)... ein Stück für mich, eins für ihn.

K: Was ist sein Name?

Y: Nano.

K: Süßer Hund. Und was ist deine Beziehung zu diesem Ort?

Y: Ich lebe hier. Das ist der Innenhof, Ich geh hier mit meinem Hund raus. Sie wollen alles neu machen, aber ich weiß nicht wann.

K: Ah den Innenhof?

Y: Es ist geplant. Schon seit über einem Jahr.

K: Hast du die Pläne gesehen?

Y: Ne, ich habe das nur von andere Anwohnern gehört.

K: Okay, also wurde es nicht mitgeteilt?

Y: Noch nicht, wahrscheinlich ist es noch in der Anfangsphase, sage ich mal.

K: Aber würdest du dich über partizipative Prozesse freuen?

Y: Ich würde mich freuen, vor allem wenn es hier grün bleibt, und alles nicht nur Betonlandschaft ist. Wir brauchen ja die Natur zum leben. Sauerstoffe und alles. Nur weil ich nicht weiß, wie die Pflanzen heißen, heißt es nicht, dass ich sie nicht mag. Ich bin auch ganz gerne im Grünen unterwegs - Was hier in Berlin immer schwieriger wird. Es wird ja immer mehr Fläche weggeholt für neue Wohnungen. Finde ich schade. Ich fände es schöner, wenn ein bisschen mehr Grün bleiben könnte.

K: Also hast du schon eine gute Beziehung zu Pflanzen, würdest Du sagen?

Y: Ich habe immer am Rand von Berlin gelebt, und da war alles immer ein bisschen grüner.

K: Ja das ist natürlich schön, vor allem, wenn man einen Hund hat.

Y: Ja eine Betonwüste ist für ihn nichts.

K: Nee, das geht nicht... Wo gehst du hier gerne spazieren?

Y: Hier benutze ich nur die Straßen, aber ich mag es lieber ein bisschen hinaus zu fahren...in den Grünewald zum Beispiel, da ist es grüner und besser für ihn (Yvonne zeigt auf Nano).

K: Ja, aber das hier ist Zuhause?

Y: Ja, in dieser Straße lebe ich seit zwei

Jahren und 4 oder 5 Monaten. Ich bin hier in der Gegend geboren worden.

K: Also hast du dein ganzes Leben in Marzahn verbracht?

Y: Marzahn-Hellersdorf, ja.

K: Schön, habt ihr eine gute Nachbarschaft?

Y: Es geht. Es ist in Berlin oft so, dass man nicht jeden zwingend kennt. Komischerweise kennt man in kleineren Orten eher jeden Nachbarn, als hier in so einer Großstadt. Aber es geht, zumindest sind alle bis jetzt sehr nett.

K: Es ist ein bisschen anonym in der Großstadt. Würdest du es schöner finden mit noch mehr Menschen in der Gegend oder magst du es so, wie es ist?

Y: Ich mag es lieber wie es ist. Ich bin nicht der Mensch, der so Menschenansammlungen liebt. Ich habe lieber ein bisschen mehr Freiraum. Einen Raum zum Atmen.

4. Nancy – Palme

K: Kennst du dich mit irgendwelchen Pflanzen hier in dem Gebiet aus?

N: Gar nicht. Für mich ist ein Baum ein Baum.

K: Ein Baum, ein Baum haha. Aber findest du, dass es einen Unterschied macht im Sommer, wenn alles grün ist?

N: Ja, im Sommer sieht es schöner aus, grüner. Aber es wird immer wärmer,

die Bäume werden nicht mehr so grün, beziehungsweise sie werden schneller wieder kahl. Aber sonst finde ich es schon schöner, wenn alles grün ist.

K: Gibt es irgendwelche Pflanzen, wo du sagen würdest: das ist mein Gefühl von Sommer oder ich könnte meinen Sommer ohne diese eine Pflanze nicht verbringen?

N: Palmen, ja. Mit den Palmen am Strand, da fühlt es sich nach Sommer an. Mit normalen Bäumen nicht. Aber so eine schöne große Palme, ja.

K: Und wo wachsen die Palmen?

N: Mallorca, Spanien, Türkei – hier in Deutschland leider nicht, aber wenn ich eine Plastikpalme finde, dann hole ich sie mir! Und stelle sie in meinem Zimmer auf.

K: Fährst du denn oft in den Urlaub?

N: Nee leider nicht, ich habe kein Geld für Urlaub. Ich muss mir die Palme im Internet anschauen.

K: Immerhin.

N: Naja, mal geht es, mal nicht. Aber eine Palme ist das, was Sommer ausdrückt, und bunte Blumen. Bäume nicht so, aber rosa und lila Farben. Ja, farbige Blumen und Palmen drücken den Sommer aus.

K: Kaufst du dir auch manchmal Schnittblumen für Zuhause?

N: Nein. Die gehen so schnell ein. Ich kaufe sie mir, und nach zwei Tagen hängen sie schon mit dem Kopf unten und machen nur Dreck.

K: Was ist dein Gefühl zu dem Ort hier?

N: Meinst du wegen den Bäumen? Oder generell, weil es so schön grün ist?

K: Ja so generell.

N: Ich wohne hier selber nicht. Ich komme aus dem Prenzlauer Berg. Ich arbeite hier nur, aber sonst mit den Bäumen ist es okay.

5. Toni und Mandy – Koriander

K: Do you have any relationship to any of the wild plants in the area, I mean outside the shopping mall.

T: No we don't.

K: Do you have any plants which are important to you?

T: What do you mean with important plants?

I: We mean plants in general.

T: I just finished school and I not going to study. Im going to work for somewhere for one year and then get an education.

I: I think you git it wrong, we asked you about plants.

M: Pflanzen...

T: Ah plants! I did not understand.. but yes important plants.. I dont know. I don't think we are looking for such a things. It might be harsh but we don't really care. We think plants are important but we would not reserch about them. I can't say much about the topic.

N: Even It is not just about re-

serching about plants; is it any you would use in your food?

T: Yes, we use a lot of herbs, in asian cooking. For example coriander. I dont know the english term for it – we speak vitnamiese, we have the vitnamiese terms. But yes we use a lot of plants for cocking, obviously.

K: Would you say the names of the herbs you are using in vitnamiese?

T: We don't know the names right now.

K: Oder auf deutsch?

T: Was benutzen wir dann alles so..?

K: Koriander!

T: This is a moment where, I know the names but I dont know right now. If my parents would say it right now.

I would know. Ah shit, Im sorry.

K: What is your feeling to the place here?

T: The area you mean? It is pretty urban I guess. I dont feel anything special. We grow up here, it is not much more to that. For a capital, in comparison to other capital, it is a bit more.. it does not look like one. What I often realised when friends are coming over is that they where „ Ah yes the Berlin...? cool“ It is pretty dirty as well. I grow up here so it is all normal to us.

K: Did you grow up in Marzahn?

T: No in Altschönhause.

I: What do you think about Marzahn?

T: Marzahn in general? We would not

go much outside. Everytime when we are coming to Marzahn ist o go here, so I can't really say much. We are more in Lichtenberg, wich is ouer district. Thats why I can't really say much to Marzahn, I have not seen much of it.

K: So today you are here fort he shopping?

T: Yes.

Taha – Rukola

K: Kennen Sie sich mit den Pflanzen hier vor Ort aus?

T: Ja, mit denen in Richtung Friedhof zum Beispiel. Dort gibt es eine, die wie Schnittlauch ist. Wenn ich die sehen, nehme ich sie immer. Ich bin da jeden Tag am Friedhof.

K: Ist es ein Wildkraut?

T: Ja, wie Schnittlauch, also Zwiebeln. Die wachsen immer, wo es Wasser gibst. Bald kommt auch Pilze. In Asien essen wir die gerne. Auch, wenn ich den Rukola Salat sehe, nehme ich den einfach mit.

K: Können Sie mir den zeigen?

T: Schau mal, wir haben hier Rukola Salat.

K: Ja stimmt, es ist Rukola.

T: Ja und der ist teuer im Supermarkt. Dabei fängt der einfach an, an den Straßen zu wachsen. In Deutschland gibt es viel. Im Park oder in de Nähe von Wasser, wächst der Salat einfach von selber.

K: Und er siedelt sich einfach von selber in der Nähe von Wasser an?

T: Ja, genau wie Schnittlauch. Ich laufe einfach jeden Tag in den Friedhof und pflücke es. Ich esse es gerne mit Eiern.

K: Das ist ja super!

T: Ja, er wächst auch im Park, ich habe ihn auch in Brandenburg gesehen. In Asien essen wir nicht so gerne aus Dosen, frisch ist immer besser. Ich koche auch gerne frisch, Hähnchen oder Rindfleisch.

K: Das heißt, du kennst dich mit Wildkräutern richtig gut aus.

T: Ja richtig. Ich esse auch sehr gerne Rosmarin. Immer gerne frisch mit Gemüse, Chili; jeden Tag was Neues. Wir nehmen immer das frische Gemüse, das an der Straße wächst. Das ist schon okay, wenn man es kocht. Ich bin schon 50 Jahre alt.

K: Du siehst viel jünger aus!

T: Ja, wenn die Deutschen mich sehen, denken die immer, dass ich 30 bin. Wenn man zu viel Essen aus der Dose oder Nudeln isst, ist es nicht gut.

K: Kennst du dich noch mit anderen Wildkräuter aus?

J: Ja mit Pilzen. Die kommen im August. Man muss aber immer vorsichtig sein, eigentlich mit allem, was man von der Straße nimmt. Es ist immer besser es zu kochen, bevor man es isst.

Macro scale

Group members:

Kaspar Jamme
Barbara Herschel
Felix Künkel

Working on the macro scale we were looking at Marzahn from a very wide perspective. In a first approach we have fundamentally tried to challenge the dichotomous understanding of city and countryside, center and periphery towards a more complex analysis of space. To point out the existing qualities of Marzahn as an area of transition between city and countryside we have developed the term intercity that on the one hand connects different urban contexts and on the other hand strongly shows its own characteristics and realities. Looking more specifically at Marzahn we have identified its in-between space - the interspace of the intercity - as a space of great transformative potential. In contrast to its current use the continuum of interspaces could be seen as a public space of appropriation, negotiation and interpretation. The richness of the city evolves out of the active involvement of its inhabitants - humans and non humans - in shaping their future environment.

Discovering Marzahn in different modes we have identified what we call typologies of appropriation - spaces, such as the field, the yard, the bridge, that show certain morphologies that are representative for the structure of Marzahn and at the same time contain an openness for a new future to be imagined. In preparation for the workshop we have documented and analysed three typologies more specifically and worked out their social, ecological and political meaning. The conflicts that revealed themselves in small fragments could then be projected back on Marzahn as a whole: the shortage of affordable housing, the redensification, the destruction of the natural environment, traffic and mobility. In this way our approach intended to break down the planning perspective from above to very specific places that

could through this be related to the daily life of its inhabitants. During the workshop we have focused on one typology, the field, a former sewage area to drain the canalisation of the inner city that has developed into a rich and biodiverse habitat over the past 20 years and is now again about to be destroyed to give way to the development of a CleanTech Business Park. By opening up the place, by alienating and modifying its components, by adding meaning and perspectives to the field, we have tried to tell a different story of how a possible future could look like. A future that involves the action of its inhabitants, its voices and needs, its dreams and wishes.

How we worked...



01

02

Preparing the
Masterplane

03

Masterplane in
Marzahn





Photo Series

Marzahn Wilderness

01

A pipe snakes
its way

02

The wilderness
swallows the
stairs





Photo Series

The Table that Wanders



01

In struggle with norms

02

In search of life on construction site

03

Have a seat!

04

What is this?
Seriously?



Intro Intercity

The history of Marzahn's development not only illustrates characteristics of Berlin's urban development, but also fundamental phenomena of urbanization worldwide.

The medieval village of Marzahn, which was first mentioned in a document around 1300 and existed for centuries as a place of agricultural use by farmers and coopers, was swallowed up by the city of Berlin through the infrastructural connection to the city in the 19th century - the expansion of the railroad, the connection of water and gas, the parcelling and sale of land, the creation of sewage fields to drain the inner-city sewage system, and finally around 1920 through incorporation as part of the district of Lichtenberg.

In the course of the urbanization process, the spatial relationship between city and countryside was reversed. The medieval village, which floated as an island in the middle of large landscapes and was connected to other settlement structures only by a coarse network of roads and dirt tracks, was connected to the urban network by the expansion of urban infrastructures and displaced by the areal spread of industry and residential areas. The dependence of the village community on its immediate, rural surroundings as a livelihood for farming gave way to the subjugation of rural areas to the expanding city. Natural spaces became interstitial spaces, destroyed, reshaped and cultivated by human impact.

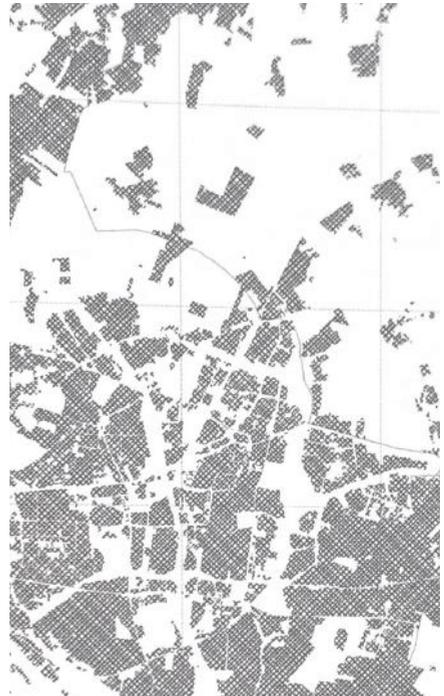
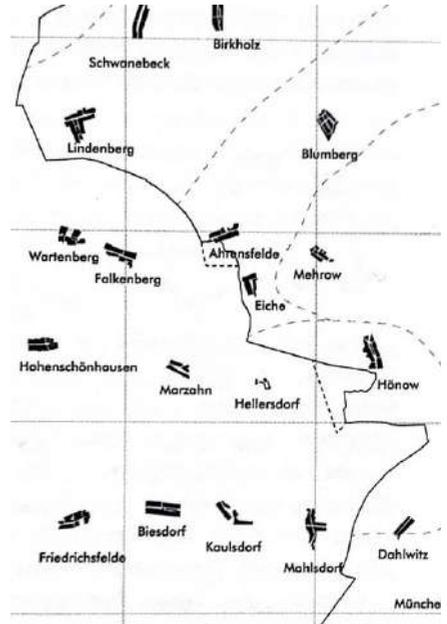

„ [...] The landscape has gone from being a comprehensive ground to a captured figure. Conversely, the settlement area has tended to take on the character of a comprehensive landscape in terms of size and openness.“

Thomas Sieverts



„The diffuse city appears altogether ,haphazard,‘ but it emerged from innumerable individual decisions - each rational in its own right.“

Thomas Sieverts

The strong contrast between city and countryside, which manifested itself for centuries in a clear boundary, dissolved into an urbanized landscape, a ruralized city.

Although Marzahn's importance as a production site, as a place to drain the inner-city sewer system, and finally as a potential building site to meet the growing demand for housing, arose predominantly from the needs and circumstances of the core city, a separate city developed out of the totality of these spatial contexts, which could be described as an intermediate city. A city that is neither city nor country, but possesses characteristics of both. The process of urbanization can be seen as a worldwide phenomenon of the development of city regardless of the historical and geographical characteristics of a specific place, so that statements about the development of Marzahn can serve as a starting point for looking at other contexts such as Milan, London, and Leuven.

In the case of Berlin, socialist urban planning was able to preserve the interpenetration of rural and urban qualities that still characterize Marzahn's spatial structure today. As a border area between Berlin and Brandenburg, between urban and rural landscapes, Marzahn can be understood as a field of tension that is able to negotiate the different characteristics, qualities and interests of the adjacent areas and actors in such a way that the coexistence of diverse ways of life can be secured in a livable in-between city.

While the term periphery is often used to describe the passive, unplanned fraying of urban outgrowths and their clash with rural phenomena, Zwischen-

stadt refers to the active process of negotiating spaces that result from the overlapping and interpenetration of sites of urban and rural qualities.

The realization of expansive in-between spaces through socialist urban planning and the overgrowth of formerly built-up areas after the fall of communism allows for diverse forms of reappropriation of the in-between space of Zwischenstadt Marzahn. In-between spaces as potential places of appropriation of space are the starting point of our vision for an inclusive development process of Marzahn.

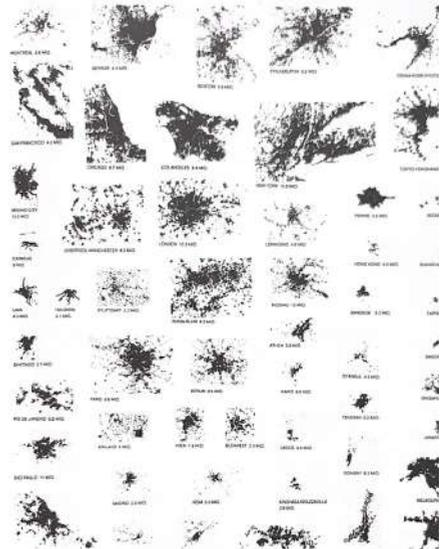

Manifest of Soziobio- diversity

We demand for more spaces of commoning and initiatives.

The practice of commoning is the source of a production of space that involves the people themselves and responds directly to their needs. The future network of initiatives is empowered to impact space, to network, to collaborate.

We demand for appropriation.

Spontaneous appropriation stimulates a different perception of the city, as a context of possibility spaces.

We demand for interspaces of resilience.

The interspaces of the city structure are occupied, used and maintained on a civil society level, equally including public and individual refuges and ecological niches.

We demand for Soziobiodiversity.

Sociobiodiversity describes the coexisting way of life of various human and non-human species within a shared living space. Our vision for the development

of Marzahn is less a fixed state than a process of transformation that opens up the interspaces of the Zwischenstadt and enables their appropriation. The different forms of life are encouraged and enabled to pursue and spatialize their desires and needs, their ideas of places of resilience. Humans, plants and animals are to be strengthened in shaping their habitat in order to make visible how rich and valuable the city is when everyone participates in its production.

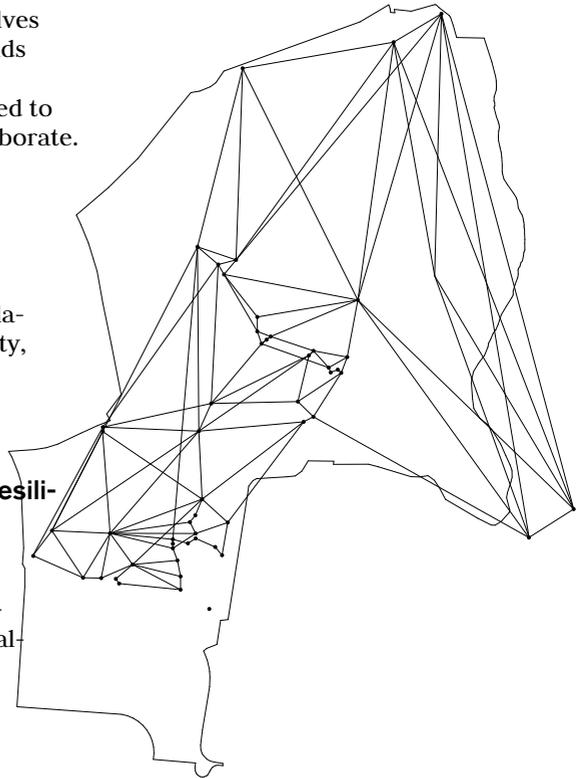

„ If there is a production of the city and of social interactions in the city, it is in the form of the production and reproduction of people by people rather than in the form of a production of objects.“

Henri Lefebvre

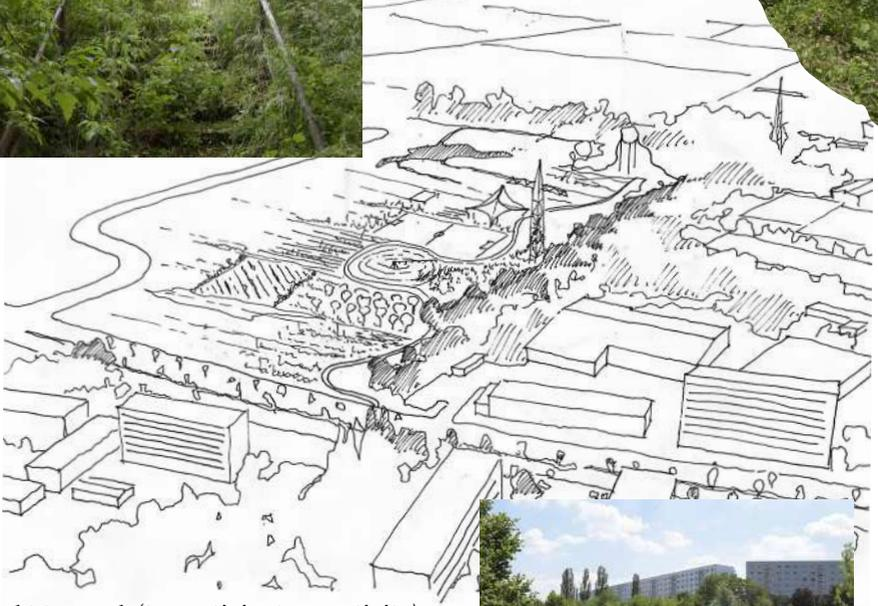

„ The right to work (to participatory activity) and the right to appropriation (to be clearly distinguished from the right to property) bring themselves into this right to the city.“

Henri Lefebvre

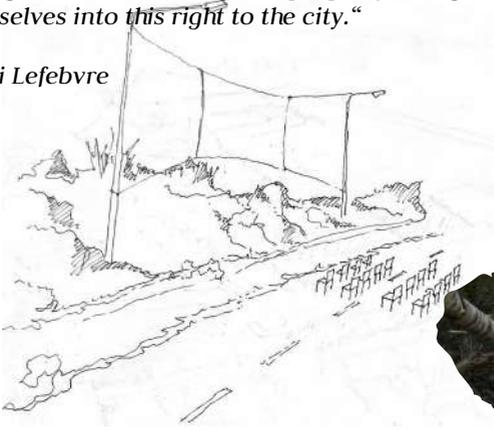

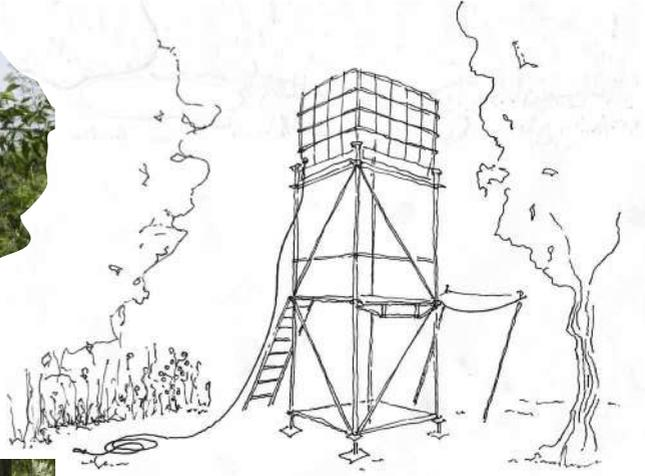

„ The ability to synthesize is a matter for political forces, which are in fact social forces [...] They exist or they do not exist, they express themselves and express themselves or they do not. They take the initiative or they don't. It is up to them to indicate their social needs, to give a different direction to the existing institutions, to open horizons and to demand a future that will be their work.“

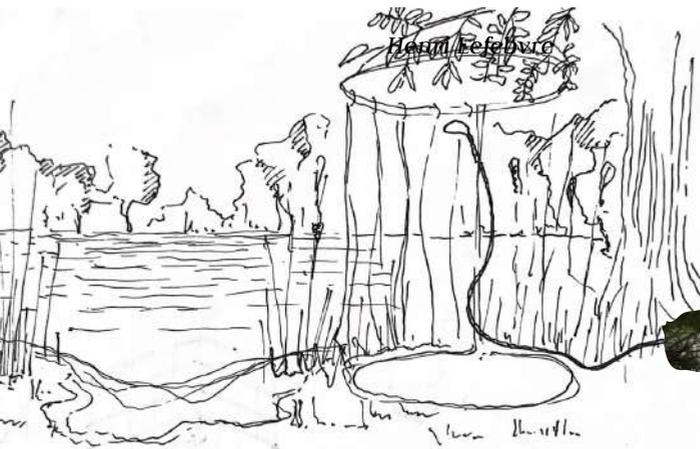

Typologies of Appropriation

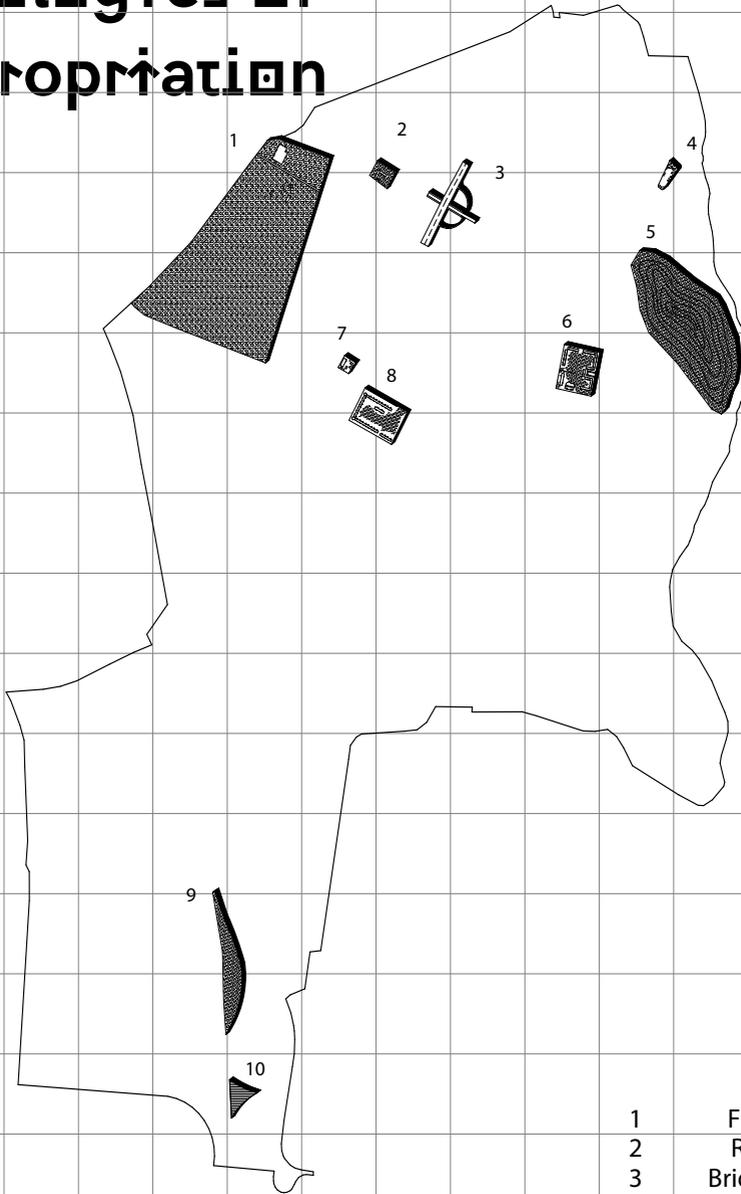

- 1 Field
- 2 Ruin
- 3 Bridge
- 4 Place
- 5/9/10 Isle
- 6/7/8 Yard

While exploring the in-between spaces of Marzahn, we came across places that can be distinguished from one another on the basis of their different space-forming characteristics. Representing these many places, we have worked out typologies that are to serve as exemplary places of contemplation and are experimental areas to try out different forms of appropriation.

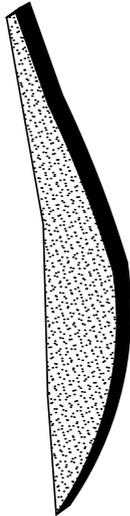
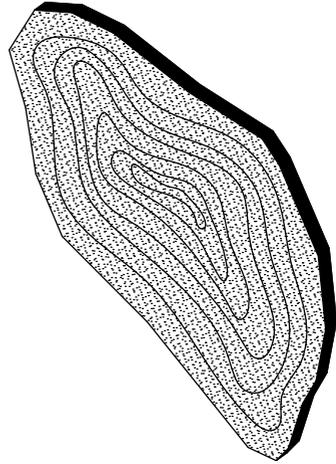

The collaborative process of appropriating a place will be documented, reflected upon, and exhibited on the site during the workshop. Between the starting point of the construction site and the selected spaces in between, a close movement is to be created so that impressions gained can have an effect on the perception of familiar places and an exchange between the groups can arise.

During the workshop we want to take a closer look at and explore three of these typologies. The three places will be observed, recorded, mapped and examined for their potential for transformation in the form of various media. We want to tease out, play, dream, imagine what these places might be, and test how we might approach our dreams and desires with what is there.

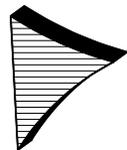





FIELD



So called „Rieselfelder“ are sewage treatment areas created by James Hobrecht in the 19th century to clean up the sewage of the inner city. Via kilometers of pressure pipelines, the wastewater reached settling basins in which coarse sediment could be deposited. The pre-cleaned water was distributed over the Rieselfelder fields via feed pumps and naturally filtered by plants and soil composition as it percolated, returning reasonably clean water to the groundwater. The trickle fields continued to be used into the postwar period, but were increasingly replaced by sewage treatment plants. A debate over environmental hazards in the form of high levels of heavy metals and deep acidification led to the discontinuation of use of the last trickle fields in the early 2000s.



Over time, the partially renaturalized and overgrown areas have developed into biodiverse landscapes that are now once again in danger of being destroyed, this time by the planned development of a major Berlin project. In the coming years, the CleanTechBusiness Park, Berlin's largest contiguous industrial area for manufacturing companies in the CleanTech sector, is to be completed.



The infrastructural development of the park by the city, the provision of media connections and access roads, took place by the end of 2015. Since 2016, the sale of land to investors has been taking place. The development plan of the area approved by the city includes detailed studies of the impact on the environment caused by the interventions. Taking into account all compensatory measures, it is assumed that 50% of the biodiversity of the site will be permanently destroyed. The ecologically completely inadequate measures are legitimized by the general economic interest in the development of such a ,future project'.

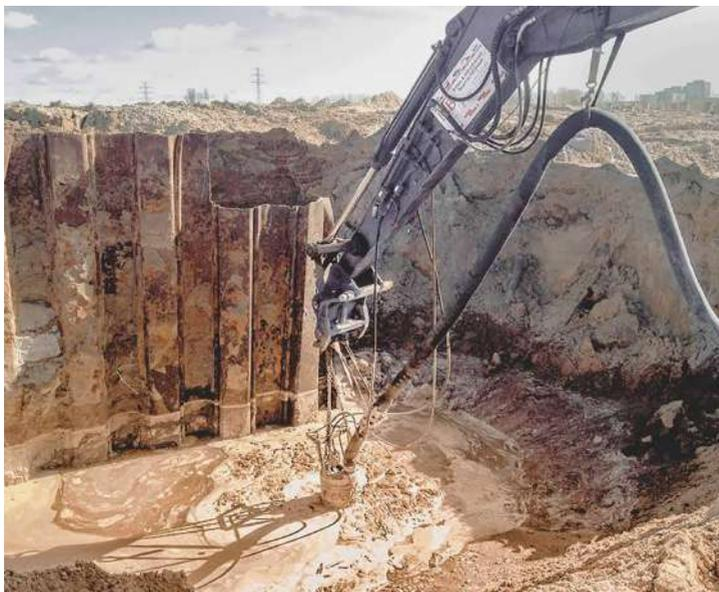

01-03

Abbruch der Kläranlage
Falkenberg (2012)

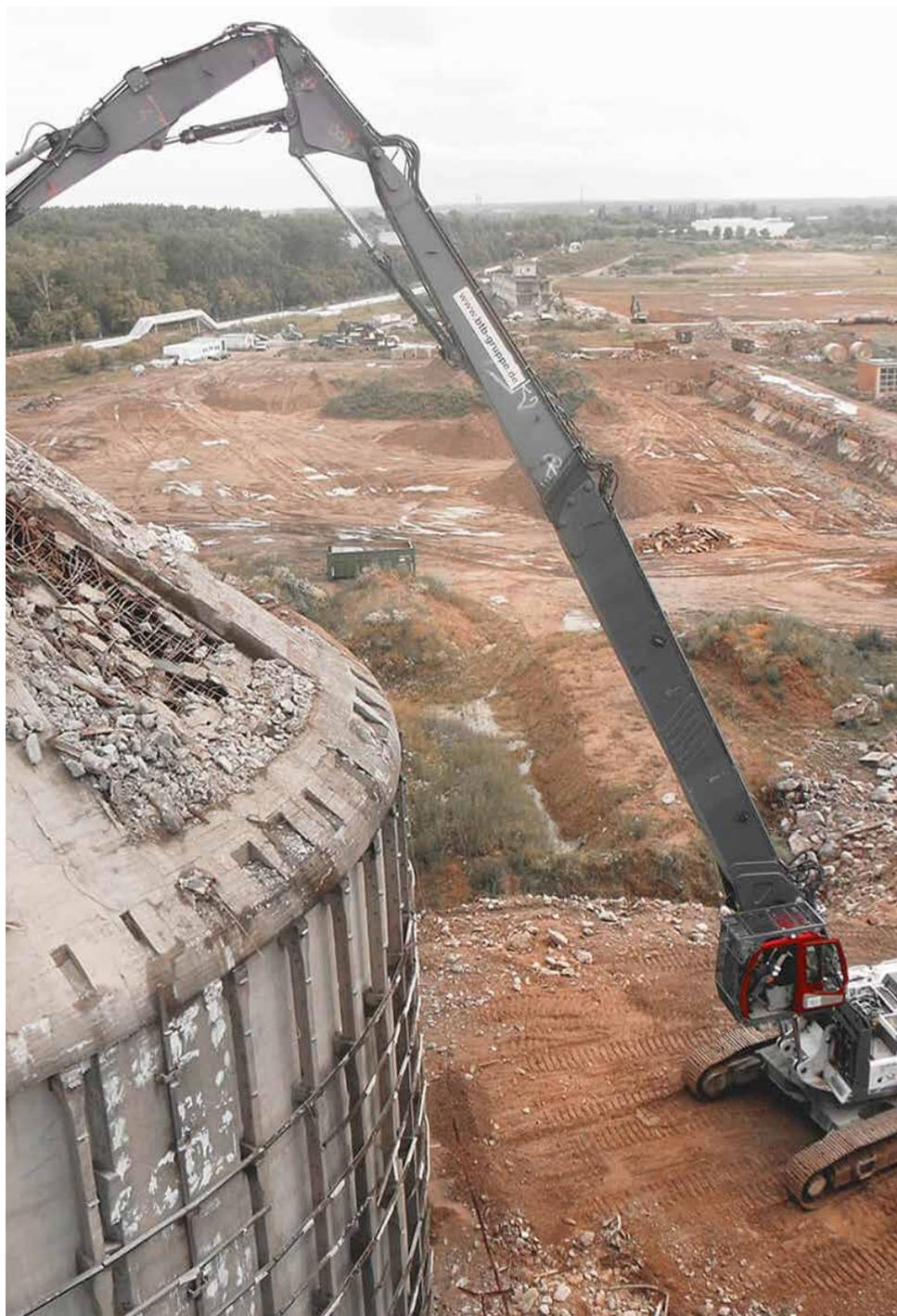



01

Development plan
CleanTech Business Park

02

Neoliberal merch

03

WISTA - 'Your Partner for
Economic Growth and
Business Development'

04

Development
of the site





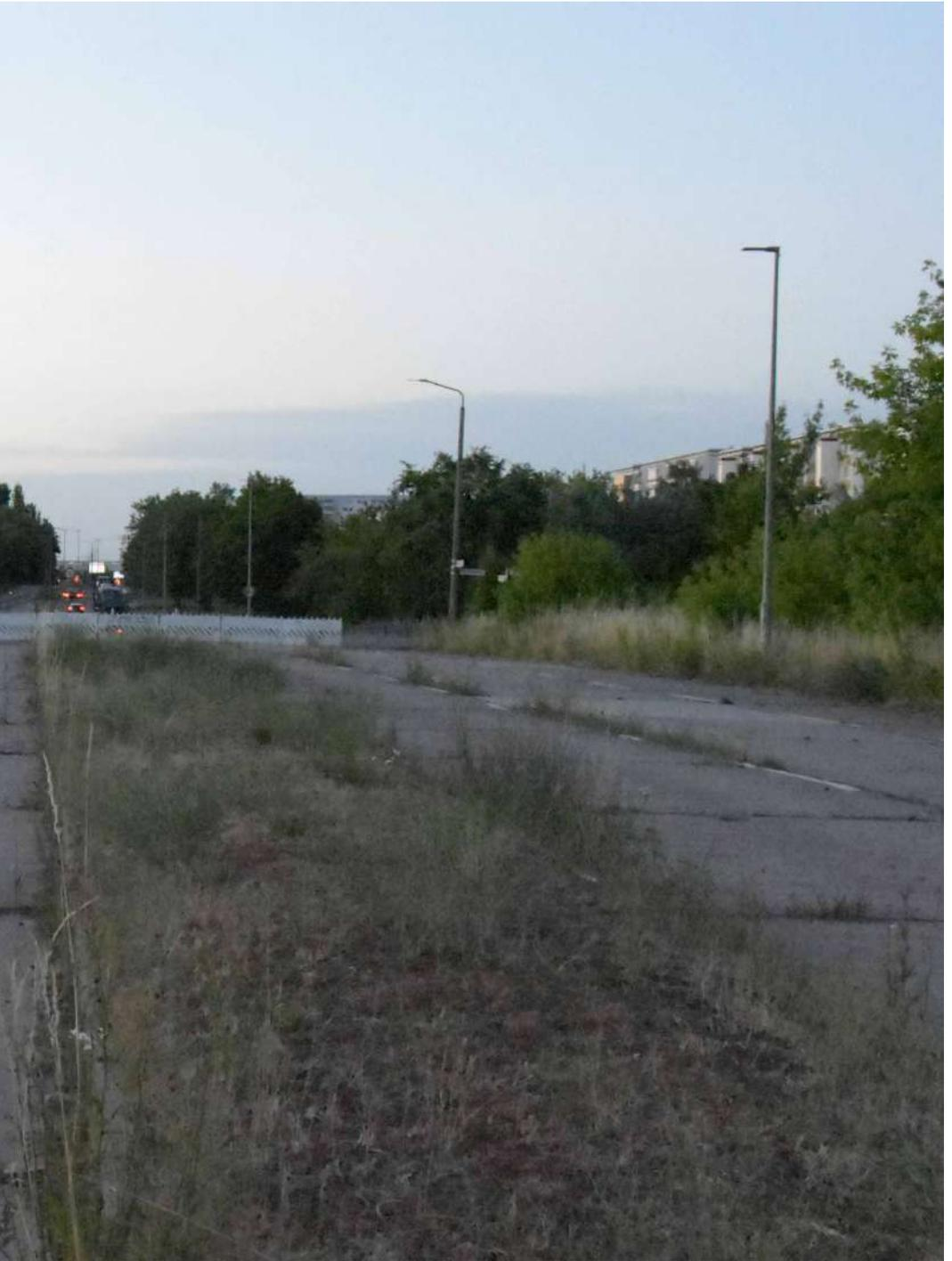

BRIDGE

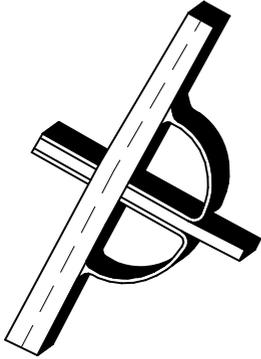

The Märkische Allee is one of the main axes in north-south direction for the accessibility of the district Marzahn-Hellendorf, an important arterial road of Berlin connecting Biesdorf and Ahrensfelde and a highway feeder road to the Berlin Ring. At the same time, the Märkische Allee separates the mainly commercial and industrial western part of the district from the large housing estate Marzahn and the Gardens of the World in the east. Intensified by the parallel railroad tracks and district heating lines, the Märkische Allee forms an insurmountable border. It predominantly has six lanes and only partly tracks for bicycles and pedestrian paths. The Märkische Allee crosses the Allee der Kosmonauten and the Landsberger Allee as an underpass, so that bicycle and pedestrian traffic must overcome the emerging height difference in a complicated way. Despite the street's strong orientation toward flowing, motorized individual traffic, traffic jams and blockages occur regularly and especially during working hours. The Wuhletal Bridge at the very north of Märkische Allee was built in 1984 and has been closed for about 4 years due to its poor structural condition. The demolition of the existing bridge and the construction of a new bridge are being planned.





Der Strassenverkehr (und damit der Lärm) auf der Märkischen Allee ist vorallem in den letzten 5 Jahren massiv gewachsen. Hinzu kommt zusätzlicher Lärm durch anderen Verkehr, wie vermehrte Lärmbelastung durch Flugzeuge und Hubschrauber und durch den Bahnring (der "Bahn-Ring um Berlin" geht nämlich mitten durch Marzahn). Durch die Vergrößerung des Strassenverkehrs ist die **Kapazitätsgrenze** der Märkischen Allee im Prinzip schon jetzt **erreicht**

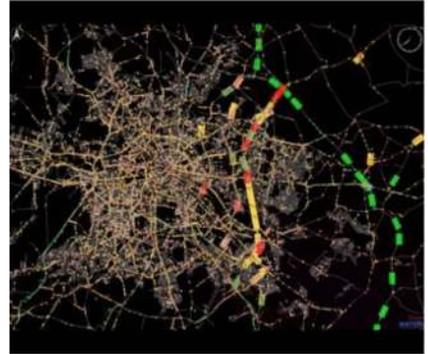

d.h. auf der Märkischen Allee ist jetzt schon meist Stau im Berufsverkehr. Durch den Ausbau der TVO wird die Märkische Allee zu einer "Hauptdurchfahrtsstrecke durch Berlin" (Verkürzung der Nord-Süd-Achse Russland/Polen mit dem Süden und Westen Europas) d.h. durch den Ausbau ist noch weiterer Verkehr und damit Lärm zu erwarten. Hier eine grobe Simulation der Lage: <https://www.youtube.com/watch?v=ECnK1AVfMDQ>

01

Wuhletal brigde
blocked since 2019

02

Connection TVO to Marzahn
(<https://www.tagesspiegel.de/berlin/sie-soll-luecke-in-der-wuhlheide-schliessen-umweltschuetzer-wollen-gegen-schnellstrasse-in-berlins-suedosten-protestieren/27108682.html>)

03

Citizen participation comment
(<https://mein.berlin.de/ideas/2019-04889/>)

04

Protest
(<https://www.qjez.de/von-marzahn-nach-koepenick-buergerbeteiligung-fuer-tvo/>)







YARD

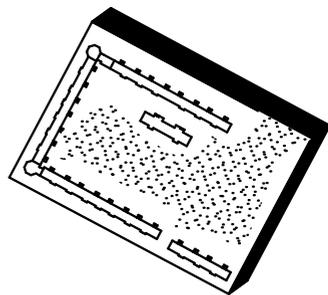

“10. The residential areas consist of residential districts, the core of which are the district centers. They contain all cultural, utility and social facilities of district importance necessary for the population of the residential district. The second link in the structure of the residential areas is the residential complex formed by a group of house quarters united by a garden designed for several house quarters, schools, kindergartens, nurseries and utilities serving the daily needs of the population. Urban traffic is not permitted within these residential complexes, but neither the residential complexes nor the residential districts may be self-contained isolated entities. They shall depend in their structure and planning upon the structure and requirements of the city as a whole.”



16 Principles of urban design, 1950 GDR



BONAVA

Wuhletaler Fenster



Beste Aussichten für ein entspanntes Leben

Schön grün ist es hier in Marzahn – und das inmitten der charakteristischen Berliner Plattenbausiedlungen.





01

Bonava

02

Bonava
(<https://www.bonava.de/immobilien/berlin/marzahn/wuhletaler-fenster>)

03

Bonava
(<https://www.bonava.de/immobilien/berlin/marzahn/wuhletaler-fenster>)

04

Competition Knorr Park
(https://www.baunetz.de/meldungen/Meldungen-Wettbewerb_fuer_Berliner_Knorr-Park_entschieden_7170395.html)

WORKSHOP ACTION

„As soon as a mythical building comes into contradiction with socio-economic reality, an empty space opens up between people's way of life and the prevailing explanation of the world, which suddenly becomes inadequate, [...]“

Raoul Vaneigem

The modernist urban structure of Marzahn is particularly rich in public open spaces, which appear as relatively homogeneous landscapes, little differentiated in design, maintenance and use. The design of the open spaces draws on a rather limited repertoire of street furniture and play and leisure facilities, materials and plants. Public space speaks a symbolic language rather than a language of use. The multitude of objects, such as benches, ping-pong tables, trash cans, fitness equipment, symbolize actions and anticipate convention. The space is no space of public negotiation as it is crowded with objects, trying to dictate to us how we should use it.

What does the place give you?

Similarly, in commercial and in only seemingly public spaces, such as shopping streets, cafes, and even retail, we are consumers of space and not involved in the place itself and its production and transformation. There is merely a freedom of choice about which offer we take, given that we have the financial means.

A democratic social practice of space appropriation and space production is needed.

What activity or thought does the place inspire?

What do you give to the place?

In our eyes, Marzahn's open spaces have outstanding inclusive potential. We understand the physical public space as the place where all living beings can exist on an equal footing. In our eyes, public space is a space of constant transformation and negotiation about who can occupy what space, how and over what period of time. Appropriation processes can develop symbiotically, can overlap, and can come into conflict with each other. In order to understand the different forms of appropriation, it is necessary to free ourselves from immediately evaluating and categorizing what we observe.

We need to look closely and impartially, listen, smell, feel, taste. We need to become aware of what we take from a place and what we give to it when we appropriate it, how we can intervene in it in order not to destroy it for others.

„On the street, the stage of the moment, I am both spectator and actor. Here is movement; the street is the melting pot that creates a civic life in the first place, and without which there would be nothing but separation, intentional and frozen isolation.“

Henri Lefebvre

During our workshop we want to appropriate spaces in Marzahn together. We propose three different places whose appropriation we want to try out. Field, yard, bridge. We want to invite other living beings, humans, animals and plants to interfere, we want to be able to tell about our experiences, we want to encourage the people in Marzahn to understand the public space as their own.

We want to propose 3 pairs of words describing possible methods of appropriation.

What do you see, smell, feel in this place?

ALIENATE & PLAY

We want to redefine the existing spatial reality by alienating its components, playing with its disaffected elements and by assembling them into new structures. Playing together, we negotiate our own set of rules and rededicate the environments protocol. Our aim is to defy the hidden logics and patterns of action within a place and recognize its transformative potentials. By alienating a place and playing with its means we are able to create a temporary world that remains accessible to others. Spectators become participants and take part in shaping another reality. They are encouraged to question their everyday practices in order to subsequently develop new ways of acting.

MAPS & IMAGINE

By observing and exploring the space, by mapping and documenting it we want to challenge our view for the unfamiliar and hidden and try to shift our habits in order to perceive other forms of consideration. We want to develop and test tools and methods that help us to challenge our visual limitations and conventional behaviors.

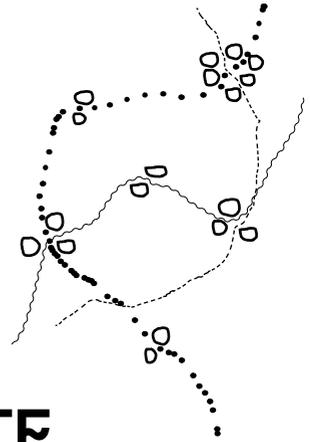

INVITE & TALK

We want to set up the place in such a way that it is open to all and encourages to imagine and articulate our dreams of and needs for appropriation. By inviting people and talking to each other we want to exchange different perceptions of spaces of appropriation in Marzahn and make them tangible in a collective approach. Not as a distanced exhibition, but as a visualization of involvement. How do we feel in a place, physically and mentally, how do we move and act, alone or together? How free do we feel? Do we know similar places in other cities or contexts that help us to strengthen our well-being?

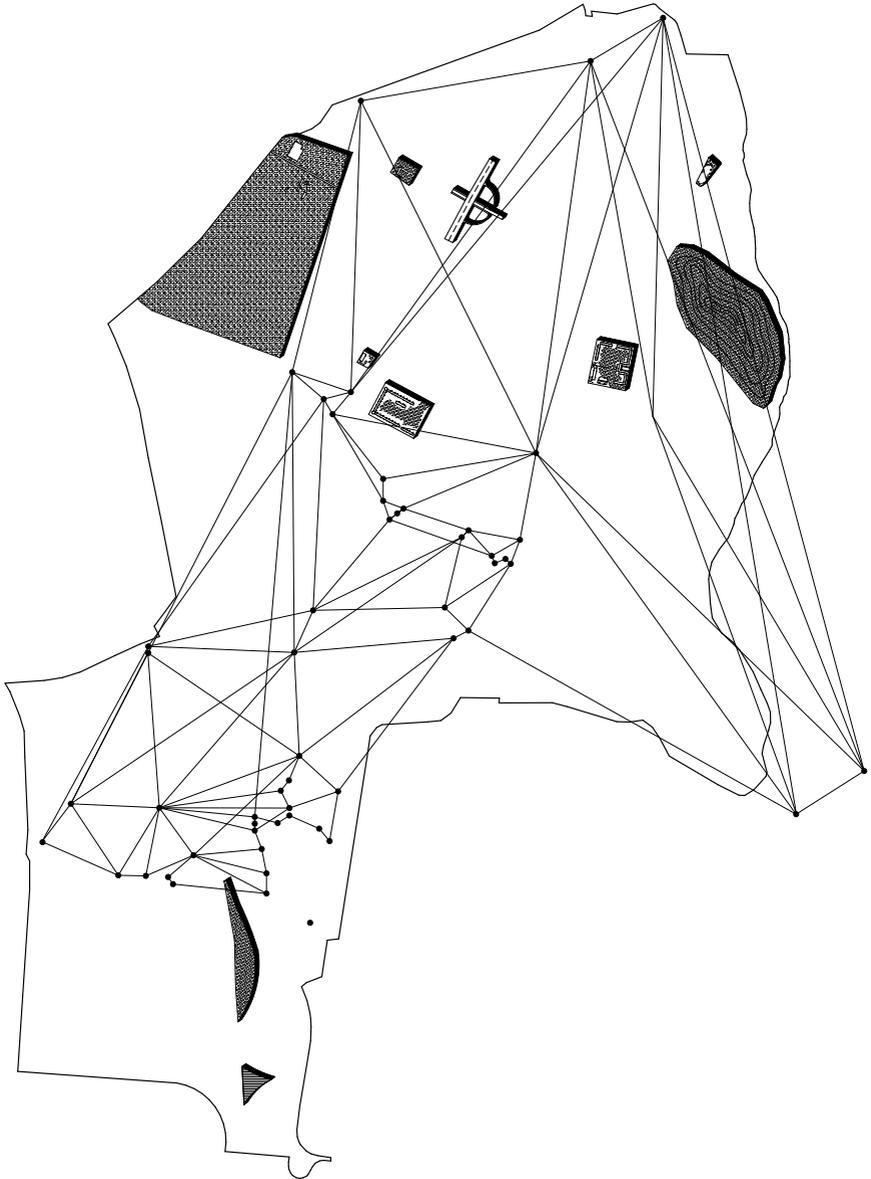





01

field studies

02

mowing



01

Elena and the rope

02

Felix and the scyth



01

02



01

Construction site

02

Material

03

Entrance to the field







01

Construction team,
very dangerous

02

The rope marks
the paths

03

Mapping the
movements of the
inhabitant of the field

04

Giving names means
appropriating



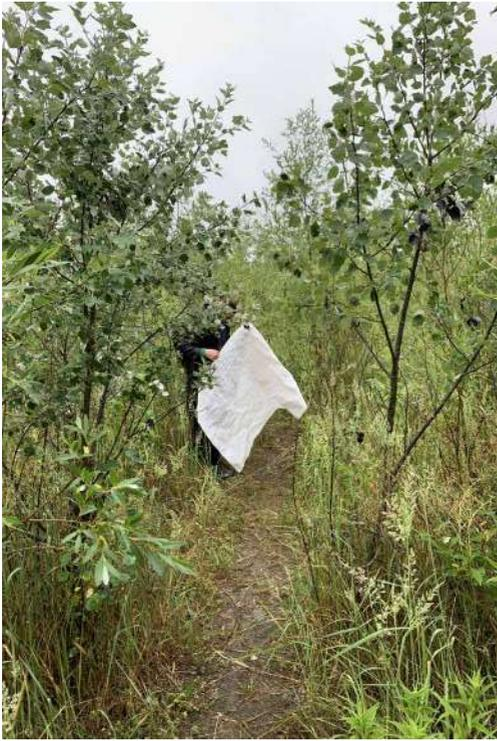



01

02

03

04

Performative
mapping







01

02

03

Construction site
of the shelter
on the edge



01

The circle
of conspiracy

02

03

Appropriating
space

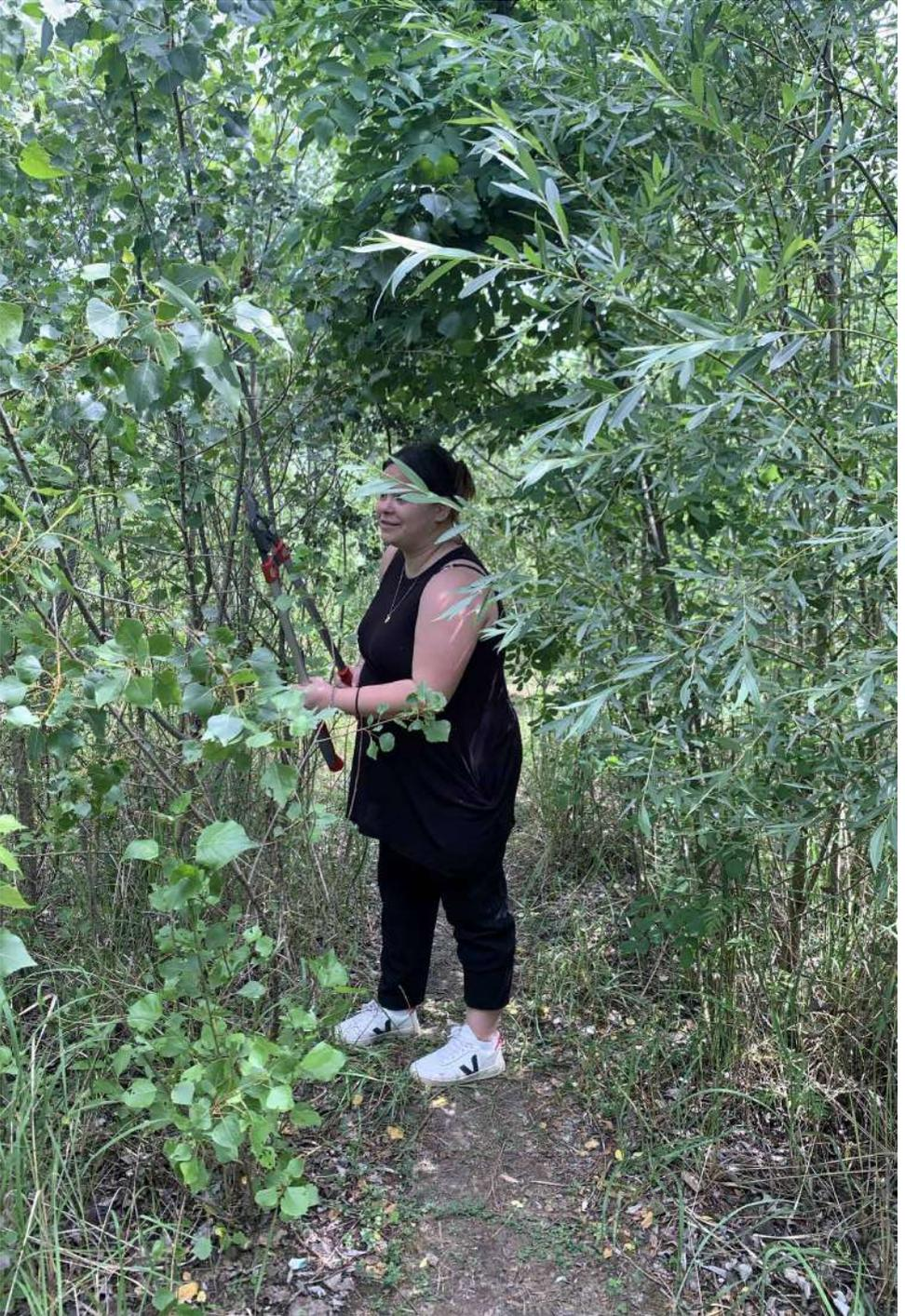





01

02

03

04

Exhibition in the
field



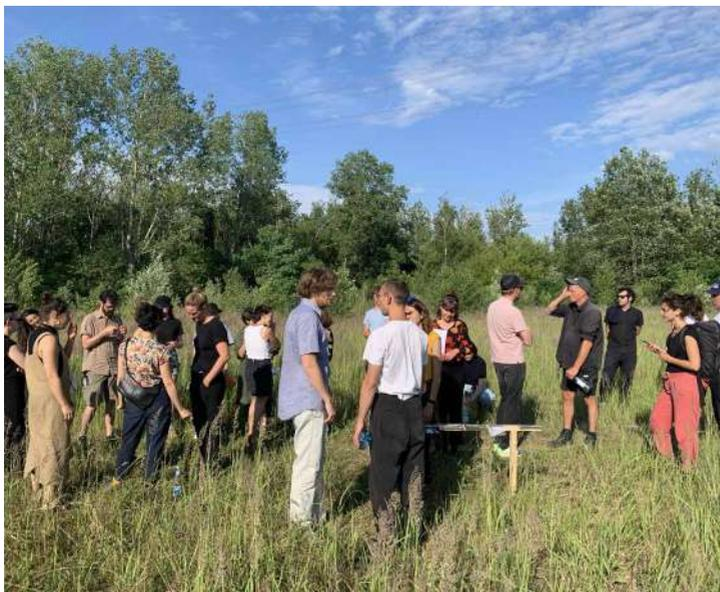
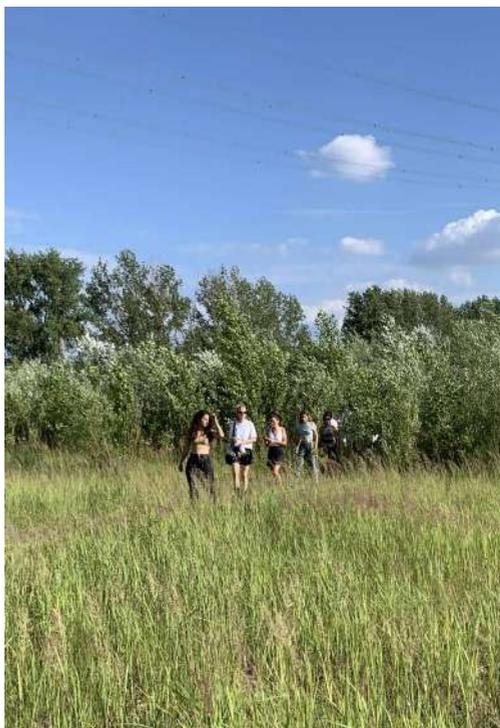

01

02

03

Exhibition in the field



Milano Workshop

Narrating & Map-
ping San Siro

After the workshop taking place in Berlin, many of the participants came together in San Siro, in a neighbourhood of the city of Milan for further studies on designing inclusion in a very different context. San Siro is often perceived as a periphery within the city of Milan. The neighbourhood was built under the fascist government following the paradigms of modern city planning.

from the about 6000 dwellings only 2000 are legally rented out. 1/3 is illegally occupied and 1/3 is uninhabited. Many of the inhabitants live in precarious conditions, experiencing governmental and social repressions. Thus San Siro has a large percentage of inhabitants with migratory background being excluded from the Milanese society, there exist a lot of informal networks and partly illegal jobs to maintain the inhabitants lives.

The workshop which was organised by the politecnico of Milan (PoliMi) and the DesInc project, took place in PoliMis Off Campus Space in the center of the neighbourhood. Off campus is a project which goes back to research activities in 2013 and is well rooted in the neighbourhood. The workshop profited a lot from the networks that have been built during the researchers work in the last 10 years. building up on that, we addressed topics of private public relations and informal social practises taking place while they are not often well visible.

As researchers we had to deal with the problems of visibility of the activities we were mapping, questioning our role and the question of how we could represent our findings in such a way that they wouldn't reveal secrets which should be kept. but also seek for ways to support the neighbourhoods inhabitants in conflicts with legal institutions.





01

Working on the
daily reflections

02

Workspace/
typical courtyard in
San Siro

03

Meeting the neigh-
bours/ local actors
of San Siro





01

Foodmarket in San Siro

02

Typical fasade of the housing in San Siro

03

"Bar Eritrea"
Meeting point and informal hub



PASSAPAROLA NIGHT

Vieni anche tu a salutare
gli studenti internazionali e
porta qualcosa da mangiare :)



CIBO • MUSICA • CINEMA

SABATO 11/09 DALLE 18:30
OFF CAMPUS VIA GIGANTE DAVANTI AL N5



01

Flyer for the event
at the last evening
"Passaparola
Night"

02

Group Picture :)

Impressum

Summer term 2020/2021
Universität der Künste Berlin
Entwerfen und Gebäudeplanung

Prof. Markus Bader
WM Dr. Katharina Rohde
Tutorin Antonia Lembcke

Contributors:

Klara Andersson
Ana Maria Chiriac
Eda Akartuna
Justus Barteleit
Luisa Pohlmann
Sophie Frehse
Asta Marie Hansen
Nursena Yildiz
Hanna Schmitthenner
Raquel Gomez Delgado
Kaspar Jamme
Barbara Herschel
Felix Künkel

Special Thanks to:

Juan Chacón
Anna Kokalanova
Federica Teti
Todosch Schlopsnies
Vera Fritsche
Ludwig Schaible
Lotta Geerds

In Cooperation with:

Stadtwerk mrzN
Schlesische 27
Desinc Live

2021



Practices of urban inclusion



Live Workshops



Live Workshops 2021

The two live workshops aim to enhance participants' capacity to work collaboratively and reflexively, engage with diverse stakeholders, map complex urban territories and produce multi-dimensional analyses of places, and envision and test potential change via performative actions and temporary interventions.



Berlin, Germany

The Berlin workshop will take place in the district of Marzahn, located on the outskirts of the city. Here, a refugee camp initially set up as an emergency shelter is now one of the largest accommodations for refugees in Berlin. The workshop will engage with this context through the 'experimental construction site' known as Stadtwerke mrzn, which was initiated by S27 in Summer 2020 as a model campus for the new citywide urban practice network.

Stadtwerke mrzn utilises art-based methods to explore how local residents can gain agency to transform both their livelihoods and the spaces where they live. The workshop will ask how art and architecture can contribute to building local resilience in the context of migration and social exclusion – particularly during the current global pandemic. The workshop will take a collaborative and cross-disciplinary approach, to understand urban space as a product of multiple relationships, and urban practice as an instrument for social change.



Otto-Rosenberg Platz, Marzahn, Berlin.

Milan, Italy

The Milan workshop will be set in the district of San Siro. San Siro is one of the largest public housing estates in Milan and a large percentage of its population has a migratory background. Despite its physical proximity to the city centre, the area is generally perceived to be part of Milan's periphery due to its challenging material and social conditions, ranging from intense intercultural and intergenerational conflicts to poor buildings maintenance. At the same time, San Siro is also home to a vibrant network of individuals and organisations – known as Sansheros – who collaborate closely to support local residents and ameliorate living conditions in the neighbourhood. Their work of Sansheroes ranges from research-based, policy-oriented initiatives, to the provision of day-to-day services such as legal counselling, language courses, and more. The workshop will engage with the reality of San Siro and its many stakeholders, addressing questions of diversity, cohabitation and care through collaborative storytelling, mapping and scenario building.



San Siro neighbourhood, Milan.

Milan, Italy

Theme: Narratives of Space

The seven-day live workshop in Milan will take place in San Siro, one of the biggest public housing neighbourhoods in Milan. The urban area is located in the North-western part of the city and was built between the 1930s and the 1950s. It is composed of around 6.000 housing units which are home to around 11.000 people. 85 nationalities are represented here, Egyptian, Moroccans, Filipinos and Peruvians being the largest communities.

The live workshop will be hosted and run by the action research group “Mapping San Siro” (Politecnico di Milano) together with Refugees Welcome Italia. Mapping San Siro is an interdisciplinary team working on issues of housing, public space, and empowerment. Founded in 2013, it has engaged in action-research and planning and worked to enhance Sansheroes, a network of NGOs and associations working in the district. Members of the network will participate in the workshop as experts. Refugees Welcome Italia is an independent organisation that promotes the mobilization of citizens to encourage the social inclusion of refugees and young migrants who arrived in Italy as unaccompanied minors.

Our engagement will be framed within the issue of narrating space and will stem from a specific provocation: What are the dimensions of inclusion and exclusion of migrant people in the neighbourhood? The workshop will be aiming at producing an original and comprehensive narration of the migrant condition in the district stemming from four fundamental axes of inquiry: work and commerce; mutual help and services for migrants (i.e., language, health, administrative status, and so forth); public space and the street; “backyard life” and neighborhood relations.

The workshop will engage with a neighbourhood that is generally depicted as “inner city”, a place of insecurity, criminality, and illegality. San Siro is indeed labelled as “little Molenbeek”, a “Casbah”, and the “Behind-the-scene” of the so-called “Milanese Renaissance” that started with the projects of urban regeneration leading to the World Exposition Milan 2015. Contrary to this description, the workshop will create room for a different way of narrating space and its inhabitants through a horizontal and cooperative relation with experts, professionals, and the inhabitants themselves. The underlying learning process can therefore be defined as “apprehending (with) the city”.

In doing so, the workshop will engage learners and teachers in mapping, interviewing, walking, and observation activities aiming at assessing the way migrant people try to find their way to inclusion with the support of local players.

The aim of the (two) workshops in Berlin and Milan is to improve the skills of learners in exploring original ways to engage with social realities of local networks and communities and identifying emerging issues, producing in-depth analysis, envisioning and testing potential change via performative actions and temporary interventions.

During the workshop, the participants will experience life in the neighbourhood and will tackle the issue of living in an “internal periphery” such as San Siro. The participants will be asked to produce outputs based on the four axes mentioned above, with particular attention to the different scales of migrant experience (the courtyard, the district, and the city). Everyone will be asked to engage in a collective process of knowledge production, which includes site explorations, mapping, creating 1:1 relations with locals, interviewing experts and local players, and reflecting on the whole experience.

IMPORTANT: Due to the current pandemic, local measures have to be applied - which means that we will work in smaller groups, keep the distance, and wear masks!

Venues

Main workshop venue: Off Campus San Siro

Address: via Giacinto Gigante (in front of n. 5)

The space is located in San Siro neighbourhood, in the north-west part of Milan

Link: <https://goo.gl/maps/cNFJq7U4RbPaDaeU9>

To get there: Underground line M5, stop Segesta

Other workshop venues:

Il Nero Distribution - viale Mar Jonio 7

Shifton - via Abbiati 1

Spazio Colibrì, Cooperativa Tuttinsieme - via Micene

Contacts

Organisation at San Siro & general information while in Milan

Stefano Pontiggia (Politecnico di Milano)

Phone: +39 3296498347

Email: stefano.pontiggia@polimi.it

Programme

Monday, 6th September

- 10-10:30 Welcome
- 10:30-11 Introduction to the workshop, *led by PoliMi & RWI*
- 11- 13 Working in groups - Walks with rooted researchers (*R. Ferro; P. Grassi; G. Orsenigo; A.Ranzini - Mapping San Siro research group - PoliMi*)
- 13-14 Lunch with rooted researchers
- 14-15:30 Working in groups - Establishing the research aims of each group, *led by rooted researchers*
- 15:30-16 Break and go to main base
- 16-17:30 Seminar - 1. Mapping as a research tool, *led by B. De Carli (LMet)*

Tuesday, 7th September

- 10-11 Seminar - 2. Local network as devices of inclusion, *led by E. Maranghi (Mapping San Siro - PoliMi)*
- 11-13 Working in groups - Dialogues with local actors, *led by F. Cognetti & S. Pontiggia (PoliMi), G. Baracco & A. Villa (RWI), S. Uberti Bona & A. Priano (Sansheros network)*
in collaboration with:
Maria Dellagiacoma & Lucia Ventura - Legal Clinic, Università Bocconi;
Nancy Boktour - Associazione Mamme a Scuola;
Daniel de la Traba Lopez - COOPI;
Valentina Valfrè - Fondazione Soleterre;
Maria Chiara Cela - Cooperativa DarCasa;
Federico Bottelli - Comitato di Quartiere San Siro;
Members of Comitato Abitanti San Siro;
Anna Todeschini - Ass. Alfabeti & Marielle Binken - Shifton
- 13-14 Lunch break with local actors
- 14-16:30 Working in groups @ *Off Campus San Siro; Il Nero Distribution space; Shifton space; Colibrì space*

- 16:30-17 Break and go to main base
- 17-18 State of the art - Sharing the research wall, *led by L. Caistor-Arendar (LMet)*
- 20:30 *Optional: dinner@P.Sarpi neighbourhood, led by PoliMi local cluster*

Wednesday, 8th September

- 10-11:30 Seminar - 3. Unpanicked Multiculturalism. Concepts, places and policies in the cities of difference, *led by P. Briata (DASU - PoliMi)*
- 11:30-13 Working in groups - San Siro explorations
- 13-14 Lunch break
- 14-16 Working in groups @ *Off Campus San Siro; Il Nero Distribution space; Shifton space; Colibrì space*
- 16-17 Reviews with rooted researchers
- 17-18:30 Break and go to main base
- 18:30-19:30 Life journeys - Introductions with local residents, *led by PoliMi & RWI, M. Castelli & A. Priano (Sansheros network)*

Thursday, 9th September

- 10-11 State of the art - Sharing the research wall, *led by L. Caistor-Arendar (LMet)*
- 11-13 Seminar - 4. Building emergent bonds for knowledge production: methods and tools, *led by PoliMi & RWI*
- 13-14 Lunch break
- 14-16 Working in groups - Life journeys: exploring the everyday life of/with the inhabitants
- 16-18 Working in groups @ *Off Campus San Siro; Il Nero Distribution space; Shifton space; Colibrì space*
- 16-18 Learning Provocation with Resolve, *led by KU Leuven & LMet*

20:30 *Optional: aperitif with hosting families & RWI activists and volunteers, led by RWI*

Friday, 10th September

10-13 Working in groups - Life journeys: exploring the everyday life of/with the inhabitants

13-14 Lunch break

14-17 Working in groups - Life journeys: exploring the everyday life of/with the inhabitants

17:30-18 State of the art - Finalising the outputs, *led by L. Caistor-Arendar (LMet)*

Saturday, 11th September

10-10:30 Introduction to aims of the day, *led by PoliMi & RWI*

10:30 -13 Working in groups - Finalising outputs to present, with rooted researchers @ *Off Campus San Siro; Il Nero Distribution space; Shifton space; Colibri space*

13-14 Lunch break

14-15:30 Working in groups - setting up @ *Off Campus San Siro; Il Nero Distribution space; Shifton space; Colibri space*

15:30-16 Break and welcoming the audience

16-19 Presentations to rooted researchers & local partners
Graphic recording activity led by Marielle Binken (Shifton)

Celebration w/ rooted researchers, local partners & inhabitants

Sunday, 12th September

11-13 Brunch with learners & feedbacks, *led by PoliMi local cluster*

Guests & local partners

Speakers:

Marielle Binken, as a graphic recorder, co-designs and facilitates collaborative events. She summarizes the participants' ideas and expressions into big drawings and text in real-time. These visuals stimulate dialogue and mutual understanding, support the sense-making process and enrich learning and engagement, allowing group-genius to emerge. Before Marielle worked for over 15 years as PR & Communication Manager in the ICT.

e: marielle.binken@gmail.com

Paola Briata, PhD, is associate professor in Planning and Urban Policy at Dastu Polimi. Her research interests, empirically situated in North Italy and in the United Kingdom, are related to planning tools and urban policy in multi-ethnic contexts; to “hyper-diverse” social mobilisations surrounding planning and regeneration; to ethnographical approaches in urbanism. On these topics, from 2012 to 2014 she has been Marie Curie Research Fellow at the Bartlett School of Planning, University College London, and she is currently consultant of the European Commission Joint Research Centre.

e:paola.briata@polimi.it

Beatrice De Carli is a Senior Lecturer in Urban Design at London Metropolitan University, and an Associate at Architecture Sans Frontières–UK. Her research and teaching employ a collaborative, design-based approach to address issues of equity, diversity and inclusion in the production of urban space.

e: b.decarli@londonmet.ac.uk

Elena Maranghi, she graduated in Architecture at the University of Roma Tre in 2010 and in 2014 she earned a PhD in Urban Studies at the University of Rome La Sapienza. Since 2013 she has been collaborating with Mapping San Siro action-research lab. From 2017 to 2020 she was a research fellow at Department of Architecture and Urban Studies (Politecnico of Milan) where she worked for the SoHoLab project (www.soholab.org), investigating the role and the characteristics of socially-oriented urban living labs in the regeneration of marginalized contexts, such as public housing neighbourhoods. Her research interests are: social housing policies, “empowerment” planning, local networks, and processes of locally based urban regeneration. Currently, she works for the Municipality of Genoa in the Urban Regeneration Office.

e: elena.maranghi@gmail.com

RESOLVE is an interdisciplinary design collective that combines architecture, engineering, technology and art to address social challenges. They have delivered numerous projects, workshops, publications, and talks in the UK and across Europe, all of which look toward realising just and equitable visions of change in our built environment.

Much of their work aims to provide platforms for the production of new knowledge and ideas, whilst collaborating and organising to help build resilience in our communities. An integral part of this way of working means designing with and for young people and under-represented groups in society.

e: info@resolvecollective.com

Mapping San Siro Research Group, DASTU, Politecnico di Milano:

Rossella Ferro, during her studies in urban planning and policy design, approached the world of countercultures, underground and social movements. She has a background in activism for the right to the city, with an eye on solidarity movements developed in Milan after the 2008 crisis and during the pandemic. She experienced the role of coordinator and trainer in projects of non-formal education, youth volunteering and intercultural exchanges. Currently, she is involved with Politecnico di Milano in a field research for the promotion of local policies to contrast housing poverty in the milanese hinterland. She is a cofounder of Frange Mobili, a cross-disciplinary collective for inclusive architecture and territorial regeneration, developing projects of cohabitation for fragile populations and cultural initiatives in contexts of spatial marginality.

e: rossella.lucrezia.ferro@gmail.com

Paolo Grassi is currently post-doc fellow at the Polytechnic, University of Milan and lecturer in Cultural Anthropology at the University of Padua. Paolo is a social anthropologist (PhD, University of Verona, and Masters, University of Milano Bicocca), with a specialisation in development (he has a second Masters in Development Project Management from the University of Milan). He also worked as a youth worker, a teacher, and a project manager assistant. Over the past ten years, he developed interests in issues relating to urban segregation, violence and insecurity, as well as the dynamics of slums and gated communities. He carried out ethnographic research in the Dominican Republic, in Guatemala and in Italy. He is member of the action-research group Mapping San Siro (Polytechnic of Milan).

e: paolo.grassi@polimi.it

Gianfranco Orsenigo, architect and PhD in Architecture, Urban and Interior Design at Politecnico di Milano. He carries out research and project in marginal contexts (neglected urban areas, public housing neighbourhoods and prisons), focusing on the capability of the design to trigger and support the regeneration process. He is a research fellow at the Department of Architecture and Urban Studies of the Politecnico di Milano within the project ACTS A Chans Through Sport a Polisocial Award 2019. The topic of sport is the tool to develop a project of spaces and social reintegration in Milanese prisons.

e: gianfranco.orsenigo@polimi.it

Alice Ranzini graduated in Urban Planning and Policy Design at Politecnico di Milano and obtained a PhD in Regional Planning and Public Policies at the IUAV in Venice. She conducts research on regeneration processes in marginal urban contexts, focusing on the role of local networks and the activation of inhabitants' and actors' competences. She is currently a research fellow at the Department of Architecture and Urban Studies of the Politecnico di Milano within the project Women4Intergration (AMIF 2021-2023), about economic and socio-spatial integration of migrant women in highly diverse neighborhoods in Europe.

e: aliceloredana.ranzini@polimi.it

Local partners:

The Milan workshop is organized in collaboration with local partners:

Alfabeti Onlus is an Italian language school for foreigners. It has been active since 1995 and became a non-profit organisation in 1999. It teaches Italian to immigrants free of charge with a view to integration, acceptance and solidarity. It was established in the heart of the San Siro neighbourhood, which has always been one of the most multiethnic neighbourhood in the city of Milan. Alfabeti is made up of 70 volunteers, aged between 22 and 81, who give lessons twice a week every year from October to June to around 200 students from around 20 different countries, including: Egypt, Sri Lanka, Philippines, El Salvador, Morocco, Peru, Nepal, Senegal, China, India, Bangladesh, Ukraine, Pakistan.
www.alfabetionlus.org

Associazione Mamme a Scuola is a project that was started in 2004 by a group of volunteers. It is not intended to be a simple Italian language school for but a path of integration that relies on mothers as a vital element for the full integration of immigrant families into our society. Its specificity from the outset has been. Its specificity from the outset was that it was set up in a primary school with the aim of creating a bridge in the neighbourhood between immigrant mothers and their children's school environment. In addition to language courses, the project includes meetings with experts on health, school, nutrition, work, issues related to residence permits and citizenship. From its first location at the Istituto Comprensivo Rinnovata Pizzigoni in Via Mac Mahon, the project has been extended to three other primary schools in Milan, including the Istituto Comprensivo L. Cadorna in via Dolci 5. In January 2011 Mamme a scuola was set up as an autonomous association.
www.mammeascuola.it

Comitato Abitanti San Siro Since 2009, the Comitato Abitanti di San Siro has been engaged in daily activism and political, cultural and social intervention from below in the working-class neighbourhood of San Siro and the city of Milan. In recent years, it has been involved in various struggles, challenges and transformative changes concerning the right to housing and habitation: it began by defending the houses occupied by families in a state of housing emergency from evictions and denounced the critical situation of thousands of public housing units left empty in the face of around 20,000 families waiting for a home. It has been involved in the process of requesting an amnesty for occupants in need. In the San Siro neighbourhood, it has been organising activities to upgrade the neighbourhood, through parties, social events and cultural activities. It has promoted self-organisation to cope with the difficulties caused by the crisis, particularly felt in the neighbourhood, by activating mechanisms of exchange and mutual aid, not only of material goods but also of skills and mutual aid.
www.cantiere.org/abitanti-san-siro

Comitato di Quartiere San Siro was founded in 1990 by a group of women with the aim of tackling the problems of the neighbourhood. It is composed of men and women who voluntarily decide to devote part of their time to try to solve the problems of their neighbourhood. Its goals are ensuring that empty and vacant council houses are allocated, restoring decorum and liveability to the neighbourhood, and promoting and encouraging cultural exchanges within the neighbourhood. The committee organises meetings with representatives of the institutions (Lombardy Region, Milan City Council, Aler, etc.) to bring the ruling class into contact with those who live in the neighbourhood; it fosters initiatives aimed at the

improvement and well-being of the neighbourhood (e.g. cleaning of the streets, etc.); it works to prevent the cutting off of services to the tenants of social housing; and it cooperates with other (recognised) organisations operating in the district.

<https://www.facebook.com/groups/631119450307422/>

Commissione Intercultura Istituto Cadorna promotes intercultural exchange activities between families, with the aim of making participation in school life more accessible to all parents and offering them an school life and offer an opportunity to get involved in the exchange with the “different”, to rethink together the value of the value of citizenship, educational responsibility and social cohesion.

Cooperativa Sociale Tuttinsieme is a social cooperative responsible for the implementation of various projects in the neighbourhood in the fields of home care, social housing and street education. It works in partnership with other organisations to provide socio-educational services that promote the well-being of people by encouraging integration and cohesion in the community and by enhancing individual and collective resources.

The Cooperative aims at providing increasingly qualified services to enhance the prospects for social, cultural and economic development.

In the San Siro district, it is responsible for the “Colibrì” diurnal centre in via Micene and the psycho-pedagogical desks at the Istituto Cadorna and Istituto Cabrini.

www.cooptuttinsieme.it

COOPI - Cooperazione Internazionale is a NGO that through the commitment, motivation, determination and professionalism of its staff, aims to contribute to the process of fighting poverty and developing the communities with which it cooperates all over the world, intervening in situations of emergency, reconstruction and development, in order to achieve a better balance between the Global North and the Global South, between developed areas and deprived or developing areas.

www.coopi.org

Dar=Casa is a non-profit co-operative founded in 1991. Its mission is to create affordable housing for low- and moderate-income citizens in Milan and surrounding areas. In order to achieve these goals, Dar=Casa obtains and then renovates vacant or dismissed apartments. Usually it rents property owned by the Municipality of Milan or other public institutions, for whose restoration or management the local government cannot provide the necessary funding.

Dar=Casa repairs the buildings and renovates apartments to rent them out to the members of the co-operative at a fixed, fair and affordable price.

www.darcasa.org

Fondazione Soleterre is a non-profit organization that works for the recognition and application of the right to health in its broadest meaning. For this reason, in addition to providing medical care and assistance, it is committed to the protection and promotion of psycho-physical well-being of everyone, both individually and collectively, at any age and in any part of the world. Prevention, report and the fight against inequality and violence, whatever the cause that generates it, are an integral part of Soleterre’s activity: because health is social justice.

www.soleterre.org

Genera Onlus is a social cooperative with 20 years’ experience in providing services to people in the Milan area and its hinterland. Throughout its history, it has developed synergies and important

collaborations with other social realities in order to respond more effectively to the needs of the territory and the community. It proposes and designs educational, social welfare and health services, but also deals with reception, co-housing and social housing. In the neighbourhood, it manages the coordination of the Social Custody Service and the Velo'cemente project, in ATI with Coop. Tuttinsieme, Azione Solidale, and Comunità Progetto.
www.generaonlus.it

Legal Clinic - Università Bocconi offers assistance and guidance on legal issues to those who request it. Legal Clinic allow students, from the end of their fourth year, to practice on real cases through pro-bono activities with the aim of: learn through learning by doing, broaden skills and consolidate relationships with leading law firms and institutions; raising awareness of the social responsibility of each citizen; and promote the recognition of rights in contexts of fragility. Legal desk is the core of the project: students, supported by teachers and professionals, offer assistance and guidance on legal issues at a number of desks directly accessible by inhabitants.

Il Nero Distribution s.r.l.s. is an independent film distribution company founded in Milan in March 2017. The company is born with the aim of presenting to the Italian audience successful cinematographic products from Egypt and other Near Eastern countries. The content proposal of absolute originality, both scenic and cultural, allows Il Nero Distribution to position itself as an element of innovation within the Italian film scene and to expand its film offer. The company takes care of the translation of the scripts into the Italian language and the dubbing, guaranteeing the preservation of the identity and cultural significance of the proposed contents.
<https://www.ilnerodistribution.com/>

Shifton - Advanced Design for Social Innovation, activates innovation processes starting from people's needs. Shifton creates positive ecosystems where people and communities can build relationships of trust and collaboration. Shifton merges profit with purpose because it combines the generation of social impact with economic objectives.
<https://shifton.it/>

Inhabitants:

We would like to thank all the inhabitants involved in the activities for their kindness and availability, and for the support to the workshop.

**Milan workshop's
curators**

POLITECNICO DI MILANO

Francesca Cognetti is associate professor of Territorial and Urban Analysis at the Department of Architecture and Urban Studies and Rector's Delegate on Civic Engagement and Social Responsibility at Politecnico di Milano. Her teaching and research activities focus on public and social housing, and social inequalities. She is the coordinator of the action-research project Mapping San Siro, an experimental living lab aimed at sharing knowledge between academia and a large-scale public housing neighbourhood in Milan.

e: francesca.cognetti@polimi.it

Ida Castelnuovo is project manager at Polisocial, the social responsibility programme at Politecnico di Milano, and she is part of the action-research group Mapping San Siro. She is PhD in Regional Planning and Public Policy with post-doc experience. Her research interests include participatory processes in urban policies, local governance, urban decision-making and public engagement of university.

e: ida.castelnuovo@polimi.it

Stefano Pontiggia is post-doc fellow in Anthropology at the Politecnico di Milano (Ph.D. in Social anthropology, University of Ferrara) and professor of anthropology at the Verona Academy of Fine Arts. He conducted long-term research in Italy and Tunisia and participated in applied research. He has research interests in migration and political asylum, power, the state, social and territorial marginalisation.

e: stefano.pontiggia@polimi.it

REFUGEES WELCOME ITALIA

Giorgio Baracco graduated in Law at University of Piemonte Orientale in Alessandria and attended a Post Graduate Course in International Relations organised by the University of Turin and the Minister of Foreign Affairs. Over the last 15 years he worked in IT and publishing fields as editor and social media manager. He is currently involved in two entrepreneurial projects focused on bridging the gap between social sector and innovation.

e: giorgio.baracco@refugees-welcome.it

Angelica Villa has a degree in International Relations. In her professional experience she has developed skills in cultural and social planning, social activism and urban regeneration. In RWI she works as a Project Manager.

e: angelica.villa@refugees-welcome.it

LONDON METROPOLITAN UNIVERSITY

Lucia Caistor-Arendar is an urbanist using research, education and design to advance social practices of city-making. She is a Research Fellow at London Metropolitan University, a Senior Associate at Social Life and an Associate at Architecture Sans Frontières UK.

e: l.caistorarendar@londonmet.ac.uk

Knowledge Corner: during the week, participants will have access to documents, reports, and materials produced over the San Siro neighbourhood in the last ten years. The documentation is part of the archive set up @ Off Campus San Siro.





Erasmus+

14.10.21

Remote meeting,
Microsoft Teams



Final Meeting

Designing and Learning
in the Context of Migration

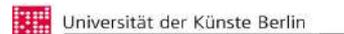

Milan workshop – core issues

Topics of reference: Narrative of Space; Care; Cohabitation; Global Migration

Main goal: understanding, representing, and narrating migration in a “peripheral”, stigmatized, and marginalized urban area

Entry point: What are the dimensions of inclusion/exclusion of migrant populations in a peripheral urban area? Which factors concur in producing inclusion/exclusion?

Work levels: commerce/work; public space/the street; courtyards and neighbour relations; mutual help and services for migrants



DAY 1: Research overview

Summary

Group members: MADHUNI, SERRA, CAROLAN, ROUSSEAU, DANIELA, SANTIAGO, SHIFTON

Group focus: individual, with

Key findings from today

- The structure of the network is...
- The structure of the network is...
- The structure of the network is...

Research Tools

Questions

Key findings from today

How can we represent the network of social actors?

DAY 2: Mapping local actors

Who did you interact with?

Quote of the day

Photo of the day

Key findings from today

How can we represent the network of social actors?

DAY 3: Mapping local practices

Research Tools

Quote of the day

Photo of the day

Key findings from today

What practices of inclusion or exclusion did you observe today?

Who?

Key findings from today



Mapping local practices

Research Tools

Write brief descriptions of tools used

Are they used in your community? If not, how could they be used?

Are they used in the wider region? How could they be used?

Quote of the day

Write a quote that resonated with you today

Write a quote that resonated with you today

Write a quote that resonated with you today

Write a quote that resonated with you today

Write a quote that resonated with you today

Write a quote that resonated with you today

Write a quote that resonated with you today

Write a quote that resonated with you today

Write a quote that resonated with you today

Write a quote that resonated with you today

Write a quote that resonated with you today

Write a quote that resonated with you today

Write a quote that resonated with you today

Write a quote that resonated with you today

Write a quote that resonated with you today

Write a quote that resonated with you today

Write a quote that resonated with you today

Write a quote that resonated with you today

Write a quote that resonated with you today

Write a quote that resonated with you today

Write a quote that resonated with you today

Write a quote that resonated with you today

Photo of the day

Write a photo that resonated with you today

Write a photo that resonated with you today

Write a photo that resonated with you today

Write a photo that resonated with you today

Write a photo that resonated with you today

Write a photo that resonated with you today

Write a photo that resonated with you today

Write a photo that resonated with you today

Write a photo that resonated with you today

Write a photo that resonated with you today

Write a photo that resonated with you today

Write a photo that resonated with you today

Write a photo that resonated with you today

Write a photo that resonated with you today

Write a photo that resonated with you today

Write a photo that resonated with you today

Write a photo that resonated with you today

Write a photo that resonated with you today

What sections of inclusion or exclusion did you observe today?

Key learning from seminar #3





Erasmus+

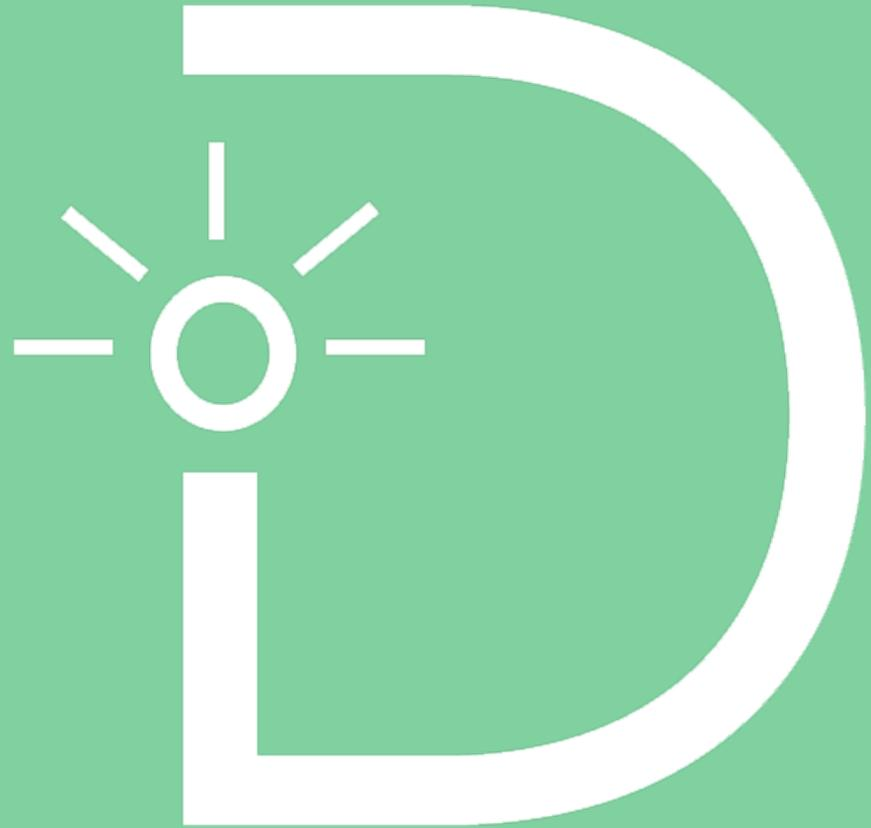

Group presentations

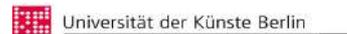

**Local networks, supports
and community dynamics
>> Informal Hubs**



Houssein



Seray



Santiago



Francesca



Rossella



Carolina



Madalina



Barbara

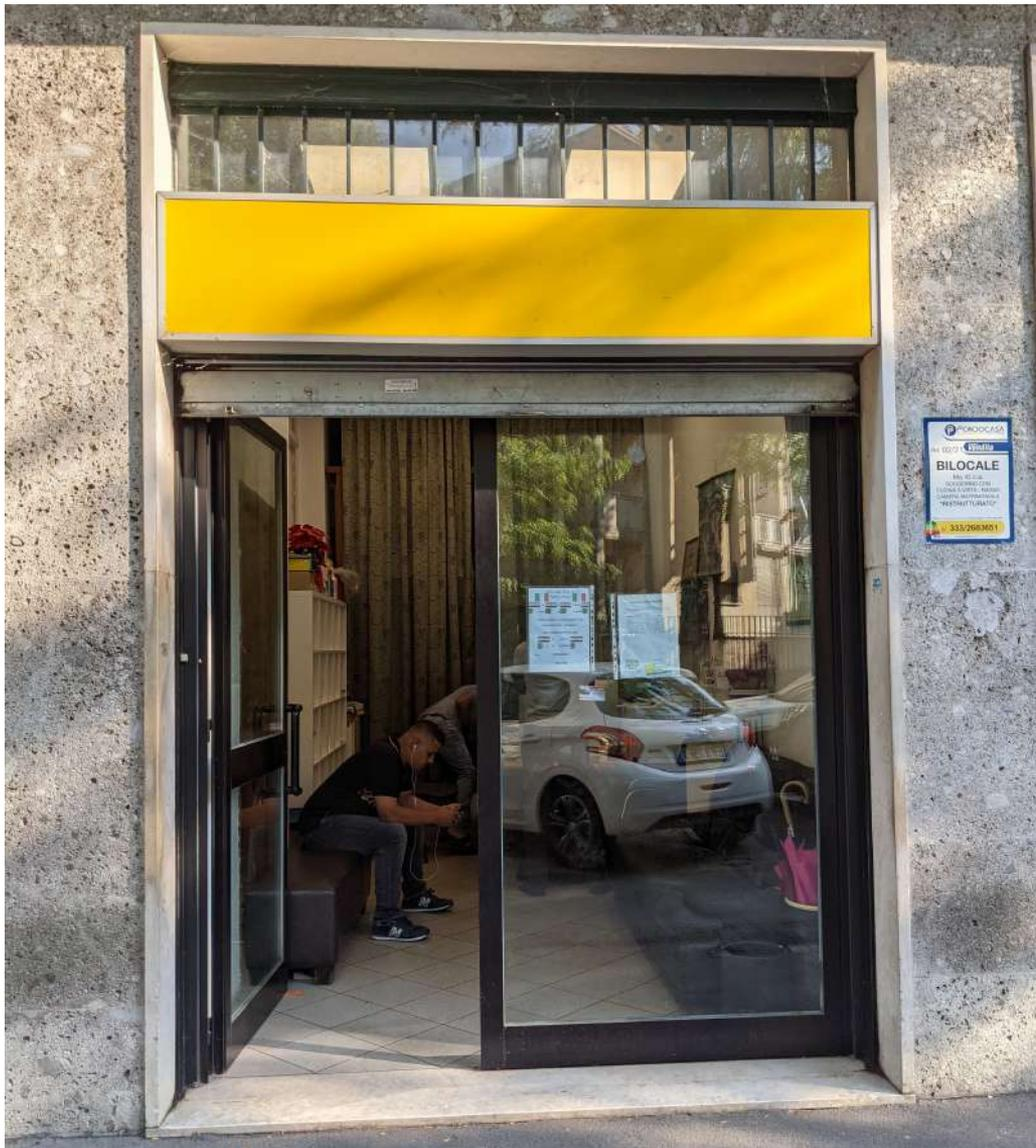

First observations: shop fronts with no description but with list of services written in the vitrine or offering an apparent service but also extending that service to other needs.



Restaurant which works as an 'Informal Hub' in the neighborhood



On the second day meeting the local network, we also understood the importance they have in the neighbourhood, but we also learned that their work extends beyond the service that they provide.

The difference in the approach between private/public and the importance of community lead initiatives (someone that has been through the process of migration)



RESEARCH QUESTIONS

Which are the relational dynamics behind accessing information and services within informal networks in migrant communities of San Siro?

What we can learn as researchers from the needs that are covered by informal networks?

What are the main tools that people use for accessing these services?



Different perspective and ideas about San Siro neighbourhood and its extension.

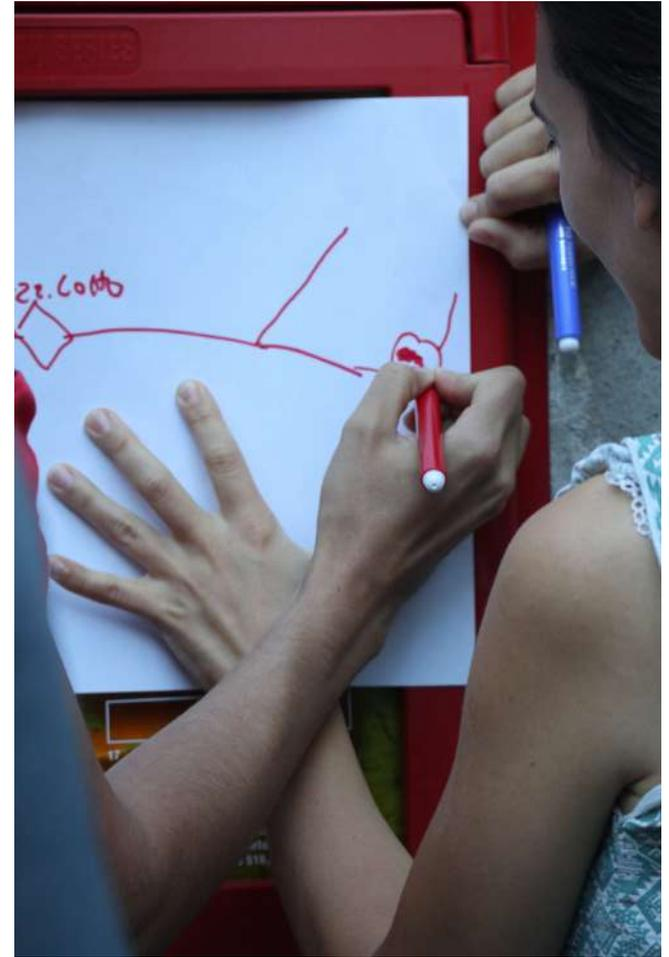



Discussion about the renewal of 'Permesso di Soggiorno'



Multiplication of agency of services and CAF managed by migrants
Connection between Giambellino neighbourhood and San Siro

RESEARCH PROCESS

(What tools and methods did you use to collect data?)

- Observations
- Documentations
- Storytelling
- Food

(Who did you speak to?)

- Shop / Restaurant Owners
- Habitants of the Neighborhood
- People identified as local leaders



Food is a good way to create the environment of 'sharing'

KEY FINDINGS

- Hidden realities are hard to reach as an outsider and it takes time to build trust
- The relevance of a shared language in the process of accessing information & services
- There is this huge role of PASSAPAROLA between the habitants of San Siro to access information & services
- The central role in a migrant community of someone that has more experience in the process of migration

OUTPUT: WHAT STORY DO YOU WANT TO TELL?

- With the 'PASSAPAROLA NIGHT' we want to create a common ground to share experiences of passaparola as a bodily experience
- Tackle exclusion of migrant communities

PASSAPAROLA NIGHT

Vieni anche tu a salutare
gli studenti internazionali e
porta qualcosa da mangiare :)

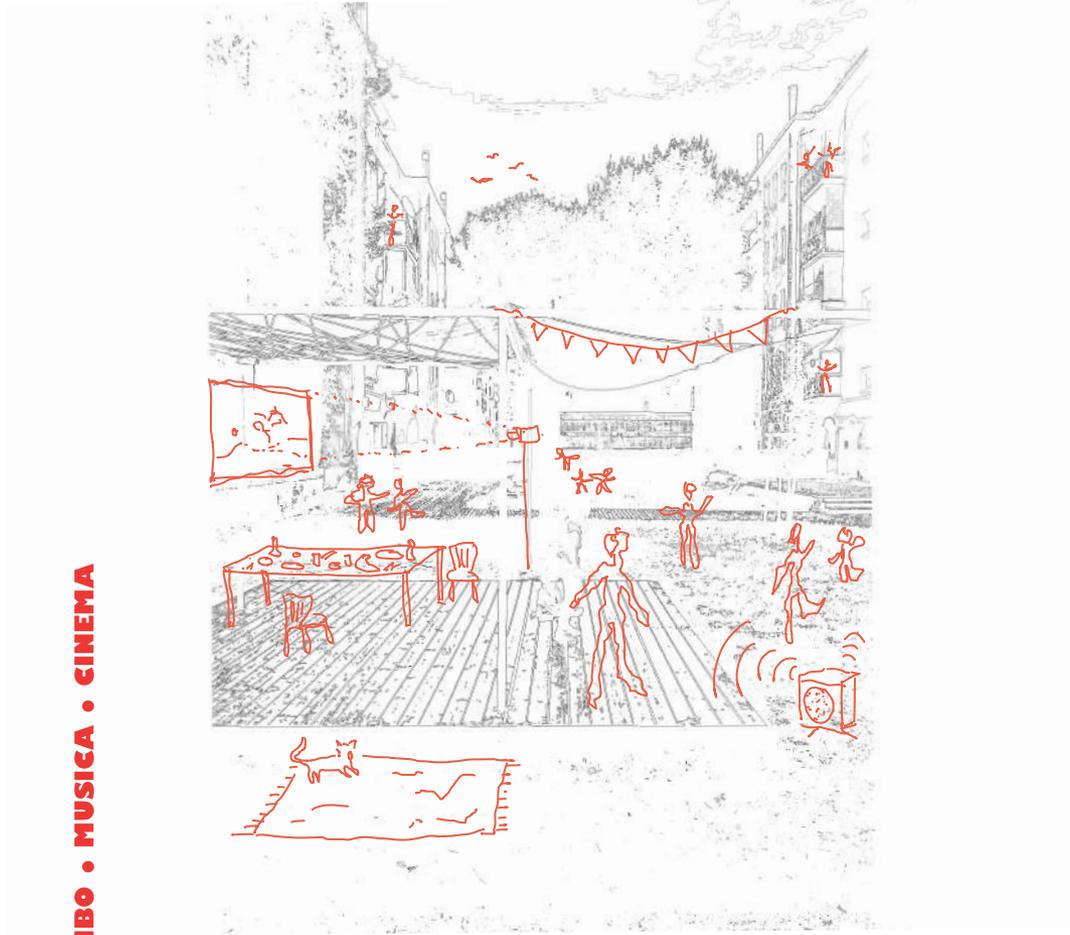

SABATO 11/09 DALLE 18:30
OFF CAMPUS VIA GIGANTE DAVANTI AL N5

Passaparola game

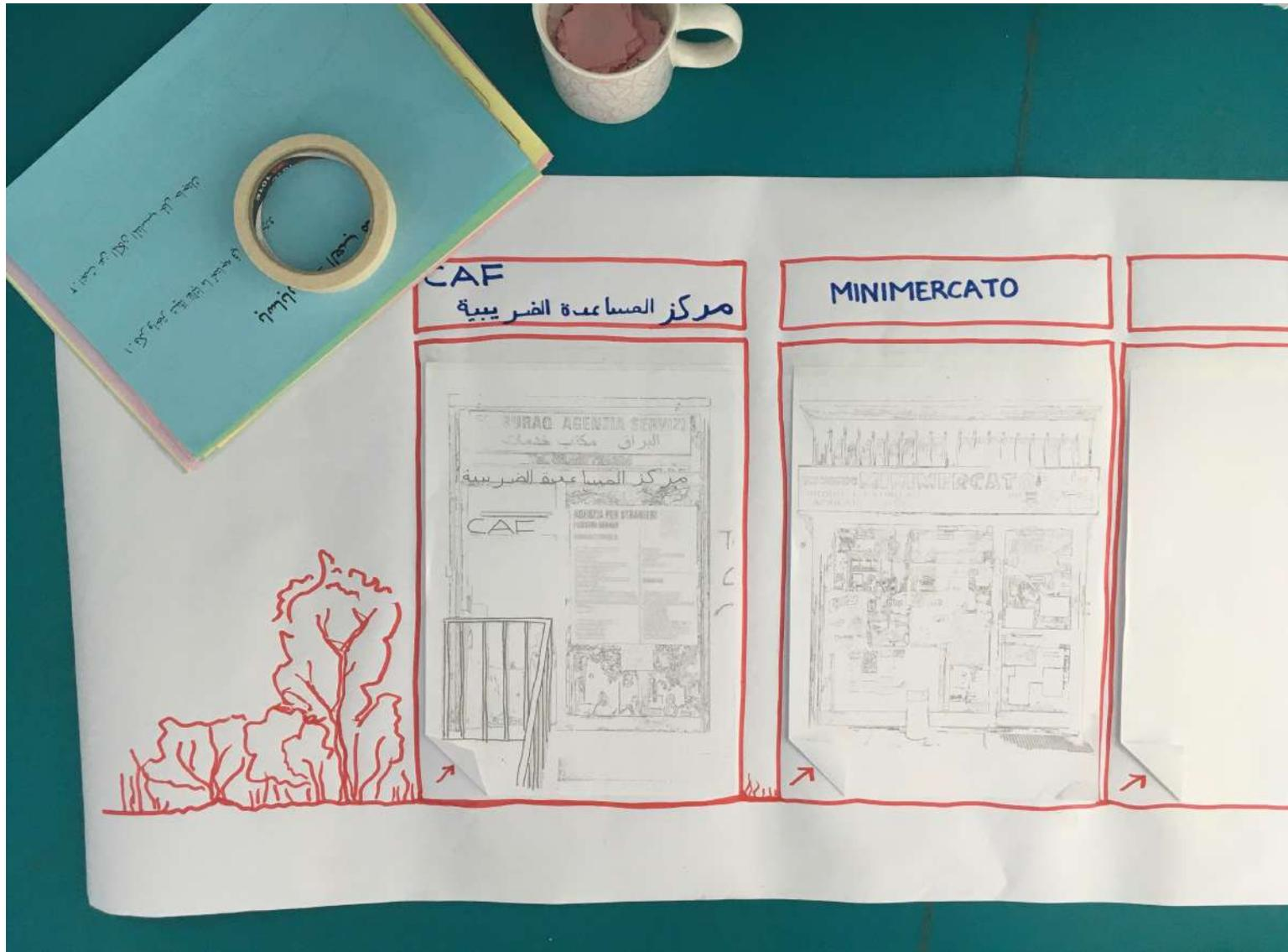

The importance of the game was to go beyond the barrier of the language



Help and support from the locals such as Ibrahim and the Peruvian restaurant

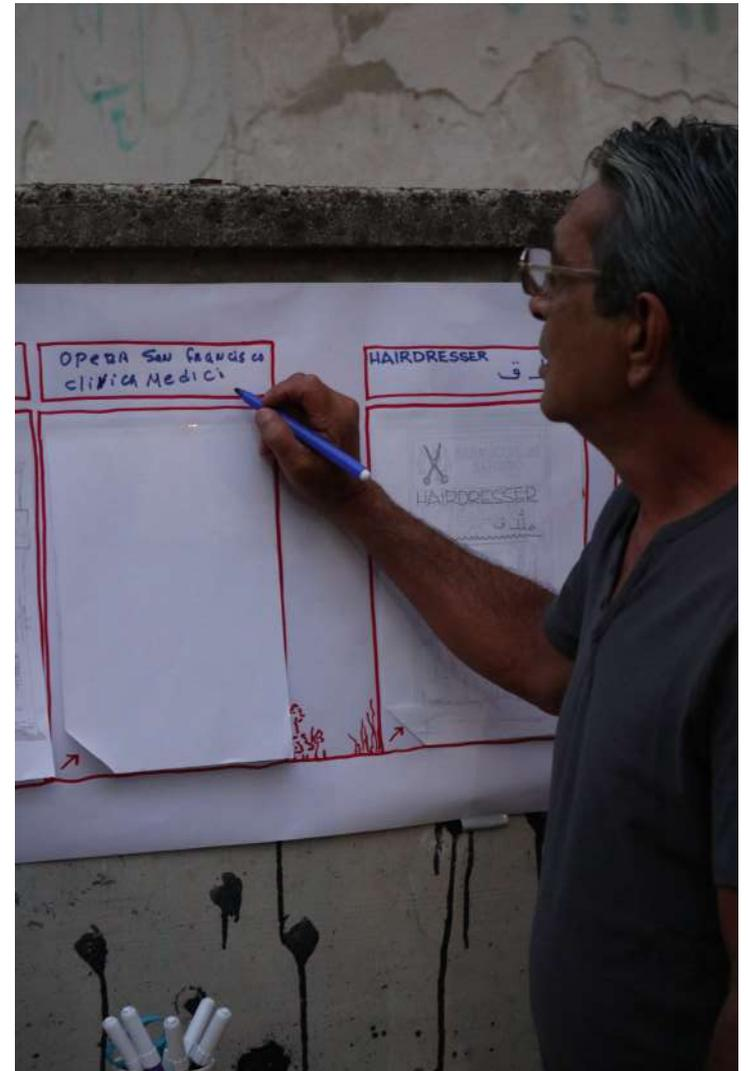

The Passaparola game creating conversations between our findings and the community, but also as a way for the communities to explore the neighbourhood create exchange .

REFLECTIONS ON RESEARCH PROCESS

(INCLUSION AND AUTHENTICITY):

How active/passive was your role in shaping the narrative?

-Our main role was to observe and document what was happening in the neighborhood in terms of accessing services and informations. We made interviews with the owners of the 'informal hubs' to better understand the dynamics in this aspect.

Whose perspective is missing? Why?

-We focused on shop owners and service provider's mainly and the service user's perspective will be covered through the game which we created as an outcome to investigate informal networks in the neighborhood.

How can you check the narrative you have created is accurate and meaningful?

-By asking our questions to multiple type of habitants from different backgrounds and social classes.

Any challenges you faced doing research?)

-To build a trust between us and the habitants to ask them about informations that we want to research took some time and effort

2

Courtyards and neighbourliness





Wall in San Siro, Take care of your neighborhood



Traces of appropriation in San Siro's courtyards



RESEARCH QUESTIONS

Q1

How do inhabitants appropriate and negotiate space in the courtyard (through conflict)?

Q2

How do inhabitants challenge the normative structure of the courtyard?

Q3

How do courtyards fit in the established narrative?
Is there room for alternative narratives?
How can one transcend the established narrative?

RESEARCH TOOLS AND APPROACH

Tools and methods:

- Observation
- Collection of traces of appropriation through photos, videos and sound recordings
- Unstructured interviews with inhabitants (different age groups, nationalities, genders) and San Heroes
- Broadening the (geographical) field of interaction

Local actors approach

- We spoke almost with 15 people coming from San Siro

GROUP MEMBERS AND ROLES

Facilitators: Paolo and Giorgio

Observers:

- Sena – Sound recording
- Sainey - Videomaking
- Anna – Sound recording, interviews
- Niside – Photographs, interviews
- Kaspar – Photographs, interviews, mapping
- Paride – Interviews, mapping, collecting traces of appropriation
- Klara – Sound recording, interviews



Group 2 at work



Group 2 at work

KEY FINDINGS

- Courtyards as hybrid spaces of negotiation
- Co-existence of different realities
- Blurring of definition of public and private space
(*transcendence*)
- Courtyards as spaces of hidden potentiality
- Planning vs. appropriation (*subversion*)
- Loop (*déjà-vu*)
- Complexity and stratification of narratives
- Interest in marginalized narratives

OUTPUT

- Courtyards on the two sides of the invisible border within San Siro:
 - contrasting existing realities
 - broadening the perspective on use and negotiation of space in the neighbourhood
- Sensorial experience of power (Surveillances, Control, Money) between the two sides of San Siro (visual, auditive, physical)

UNFOLDING SAN SIRO: OPPOSITE (?) TWINS?

The starting point of Stigmatization?
The Constitution of Narratives
The Crisis of Perspectives
Negotiating Spaces
Traces of Appropriation
Maps of Possibilities

The way in which realities are perceived depends on the stories that are told. Realities are getting processed, interpreted and translated into a network of stories that in turn affects the people's perception of the realities they talk about. The network of narrations forms the way people see, position and think of themselves. It constitutes the frame of reference, the social belonging, the state of mind from which the new stories are told. The perception of people is in constant movement, as are the narratives that they produce. In that sense, narratives are vague, are unprecise, are deceptive. Very much they depend on the intention, the interest, the perspective and position of the narrating person. Narratives told in a louder voice are heard more often while quiet stories remain unheard.



UNFOLDING SAN SIRO

UNFOLDING SAN SIRO: OPPOSITE (?) TWINS?

Comfort looking zone

Space negotiation

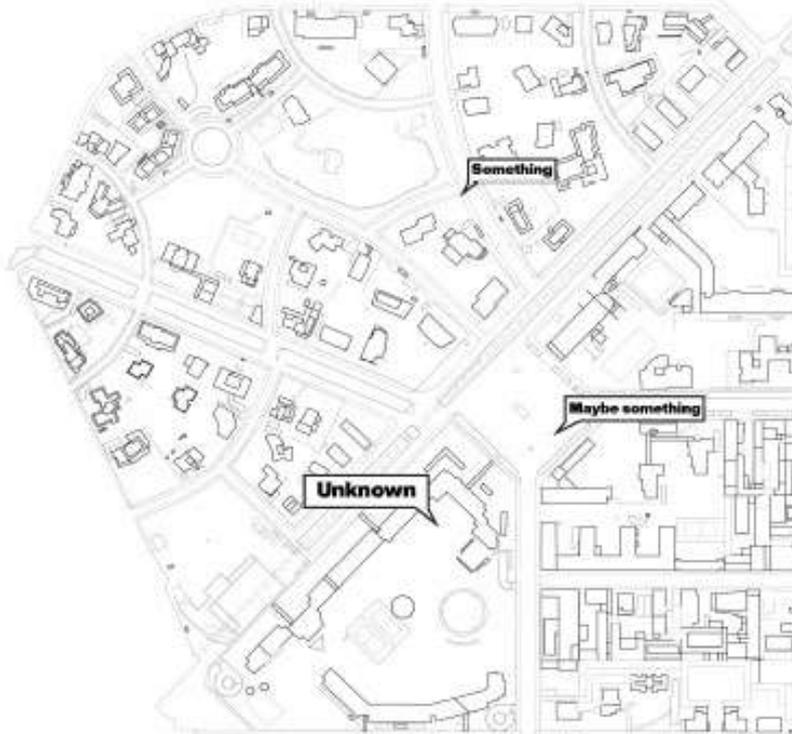

Normative structure

Sorry for the eavesdropping

Can I get into?



Appropriation

UNFOLDING SAN SIRO: OPPOSITE (?) TWINS?

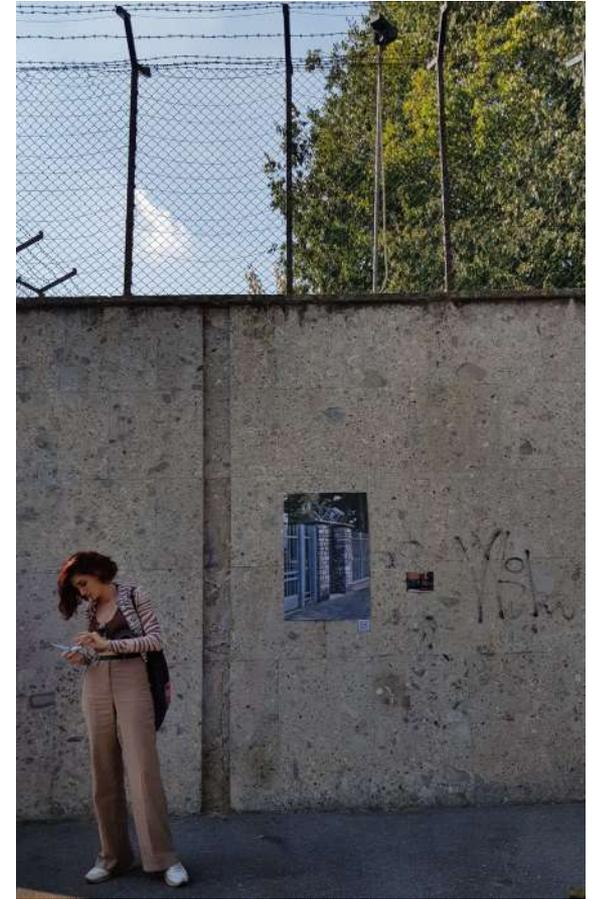

UNFOLDING SAN SIRO: OPPOSITE (?) TWINS?

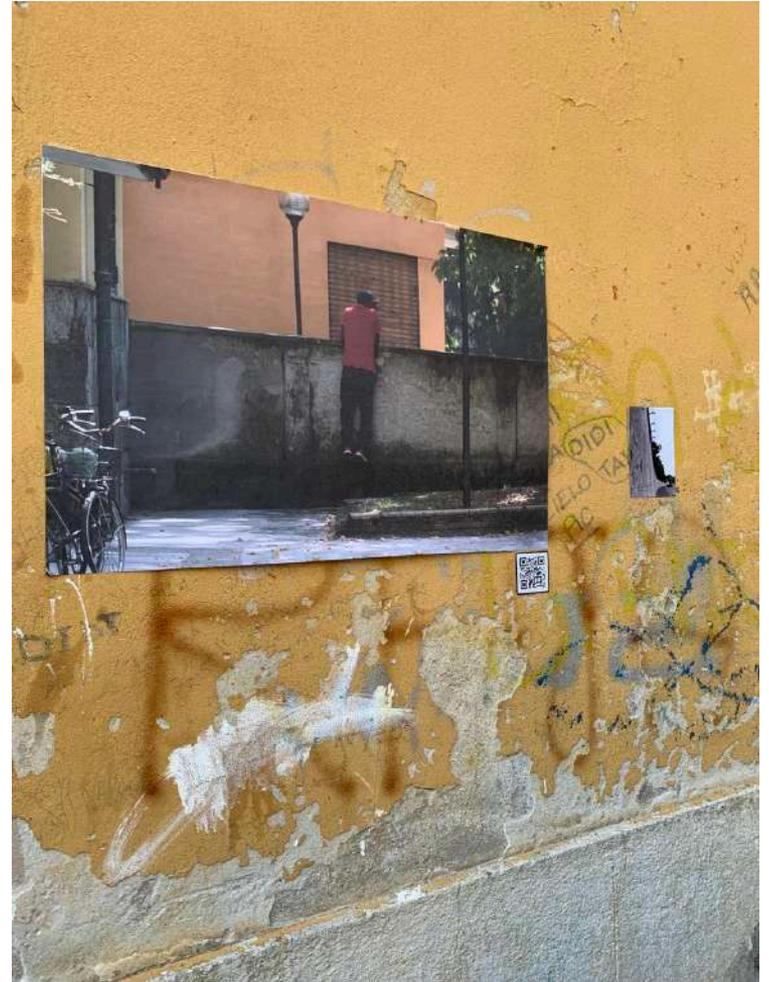

UNFOLDING SAN SIRO: OPPOSITE (?) TWINS?



REFLECTIONS ON RESEARCH PROCESS + OUTPUT

Challenges:

Our role: actively shaping the narrative

Offering a new perspective rather than a strong narrative

No claim of general validity and completeness

Linguistic barriers, lack of time/resources

Crisis of perspectives

3

**Commercial spaces
and work**



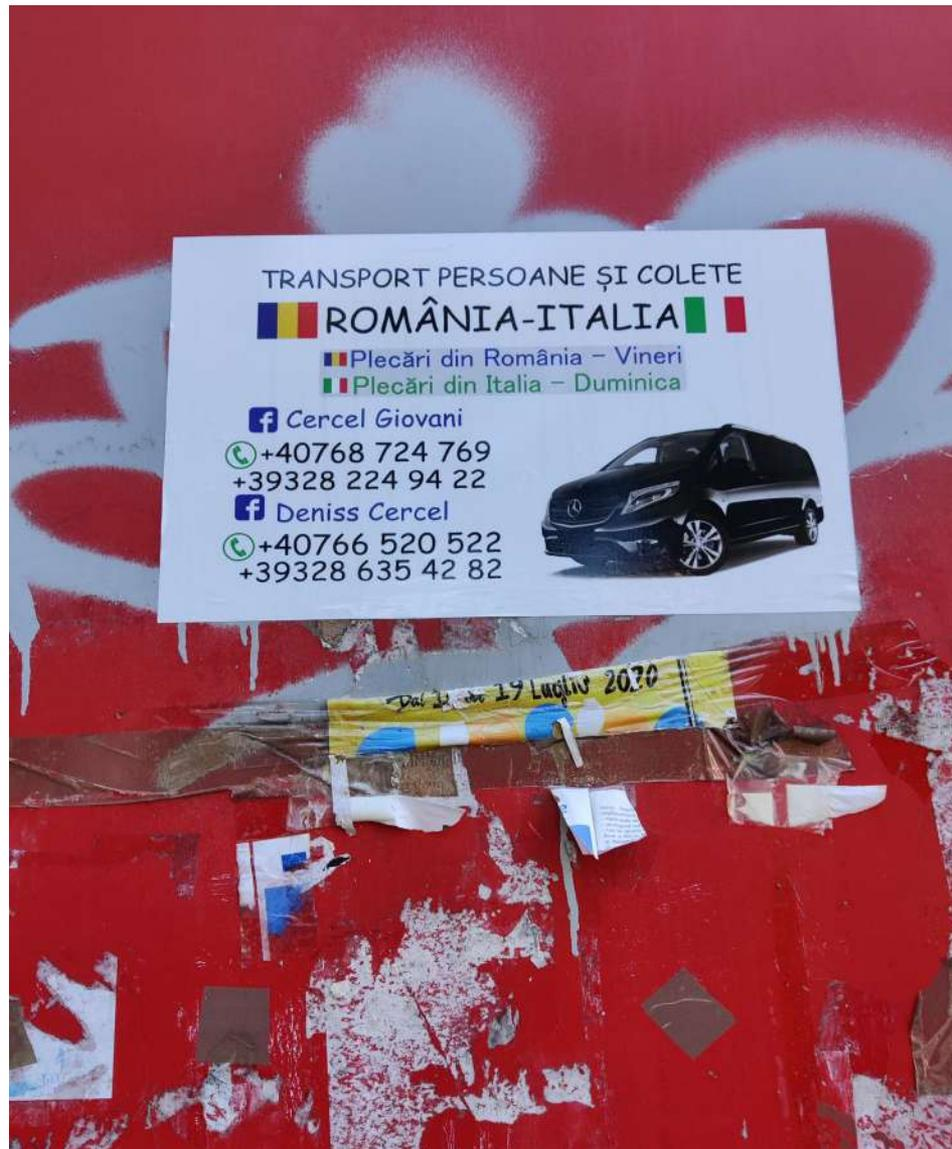

Transportation services between Romania and Italy advertised in San Siro



Mimmo, Egypt, bakery owner in San Siro

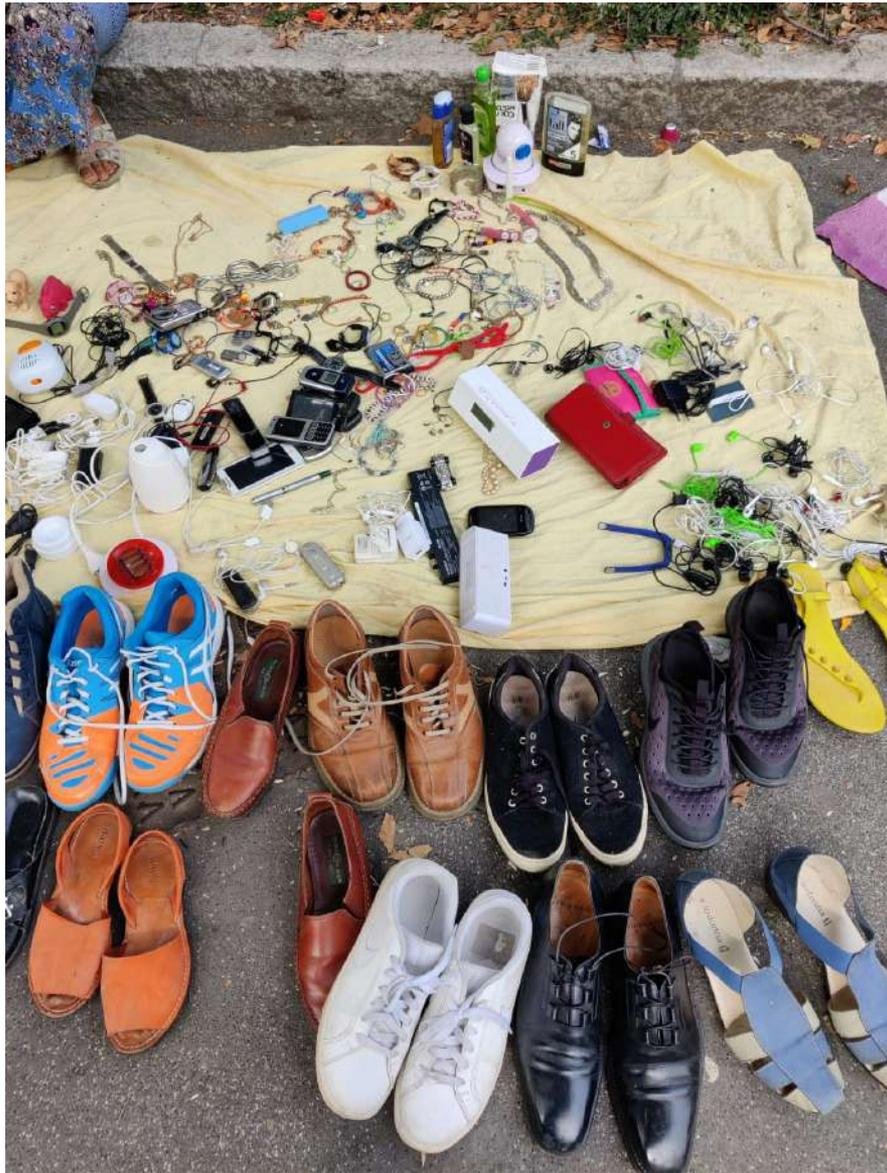

Street vending in San Siro



Alexis, Salvador, Harid and Giomar, the team of Salsa Pa Ti, a Peruvian restaurant in San Siro.

RESEARCH QUESTIONS

What are some of the ways in which people in San Siro make a living?

How does commerce and work in San Siro generate dialogue across places and people?

What are some of the networks that emerge from commerce and work activities in San Siro?

RESEARCH TOOLS AND APPROACH

The main research tools have been one-to-one interviews, daily surveys, pictures but also personal involvement in local activities such as having lunch in different restaurants. Through this approach we have been able to talk with almost 15 people in the neighborhood that have a different lifestyles and told us several stories.

GROUP MEMBERS AND ROLES

Ana Maria – Interviewer+photographer+illustrator+writer; Elena –

interviewer+photographer+illustrator+writer; Lucia – interviewer+photographer+illustrator +writer,

Sebas – Interviewer+photographer+illustrator+writer; Ian – Interviewer+reporter



3rd day of work in Colibrì workspace

KEY FINDINGS

Work trajectories and commercial activities in San Siro vary greatly. For instance, established business owners (from the neighborhood and elsewhere) coexist with people in extremely precarious work situations-
-and everything in between.

Specific commercial and work activities in San Siro and their associated individual narratives illustrate the complex network of relations and trajectories that converge in San Siro across scales.

OUTPUT: WHAT STORY DO YOU WANT TO TELL?

Stories of (ex)change: life and work trajectories in San Siro

Our project aims to visibilize the wide range of ways and practices through which San Siro inhabitants earn their living. Through the lens of three individual stories turned into guided walking tours and a final exchange session, we hope to shed light on the diversity of activities in San Siro, and the way in which they connect different trajectories of people and goods.



Final Output during the final exhibition

REFLECTIONS ON RESEARCH PROCESS + OUTPUT

The final output has been the definition of three stories/paths; partial and unable to represent the complexity or diversity of work situations or trajectories in San Siro. However, our hope is to illustrate different conditions in a context usually represented as relatively monolithic.

The differences between these stories result in different levels of involvement from the side of the protagonists in shaping and verifying these stories. Consequently, our role in curating these narratives varied greatly from case to case.

One of biggest problems was the available time; get closer to people and know their stories in a short time contributed in shaping partial narrative.

“You have two degrees, like me. Imagine suddenly going somewhere and that all those years go to waste, don’t mean anything. Imagine having to start completely from zero”

-Giomar, Peru, 34. Business owner in San Siro.

4

Public spaces and the street





Child climbing over courtyard fence



Interview with Café worker in San Siro



Children interacting with our urban intervention in Piazzale Selinunte



Asking children to draw Sansiro



Planting a tree

RESEARCH QUESTIONS

What is the impact of paternalistic interventions in the public realm?

What are the spatial practices of women and children in the public realm?

What are the different perceptions of San Siro's public realm?

RESEARCH TOOLS AND APPROACH

Tools and methods:

- Interviewing
- Observation
- Photography
- Spatial Intervention
- Play

Who did you speak to?

- Local organization (Off campus, Alfabeti school, ...)
- Inhabitants
- People at work

GROUP MEMBERS AND ROLES

A collaborative work from all of us:

Felix, Eda, Sarah, Joelle, Sareh, Maha



KEY FINDINGS

- The interventions have led to certain social spatial practices moving into or out of public realm.
- Women socializing in public realm tends be the outcome of looking after children and/or informal trading (Roma community)
- Urban realm is divided by invisible boundaries defined by different groups of people.

OUTPUT

We had a tour of some of the public spaces we had worked during the workshop to explore different perceptions and stories. We tried through this tour to share our own findings and ask the others perception.

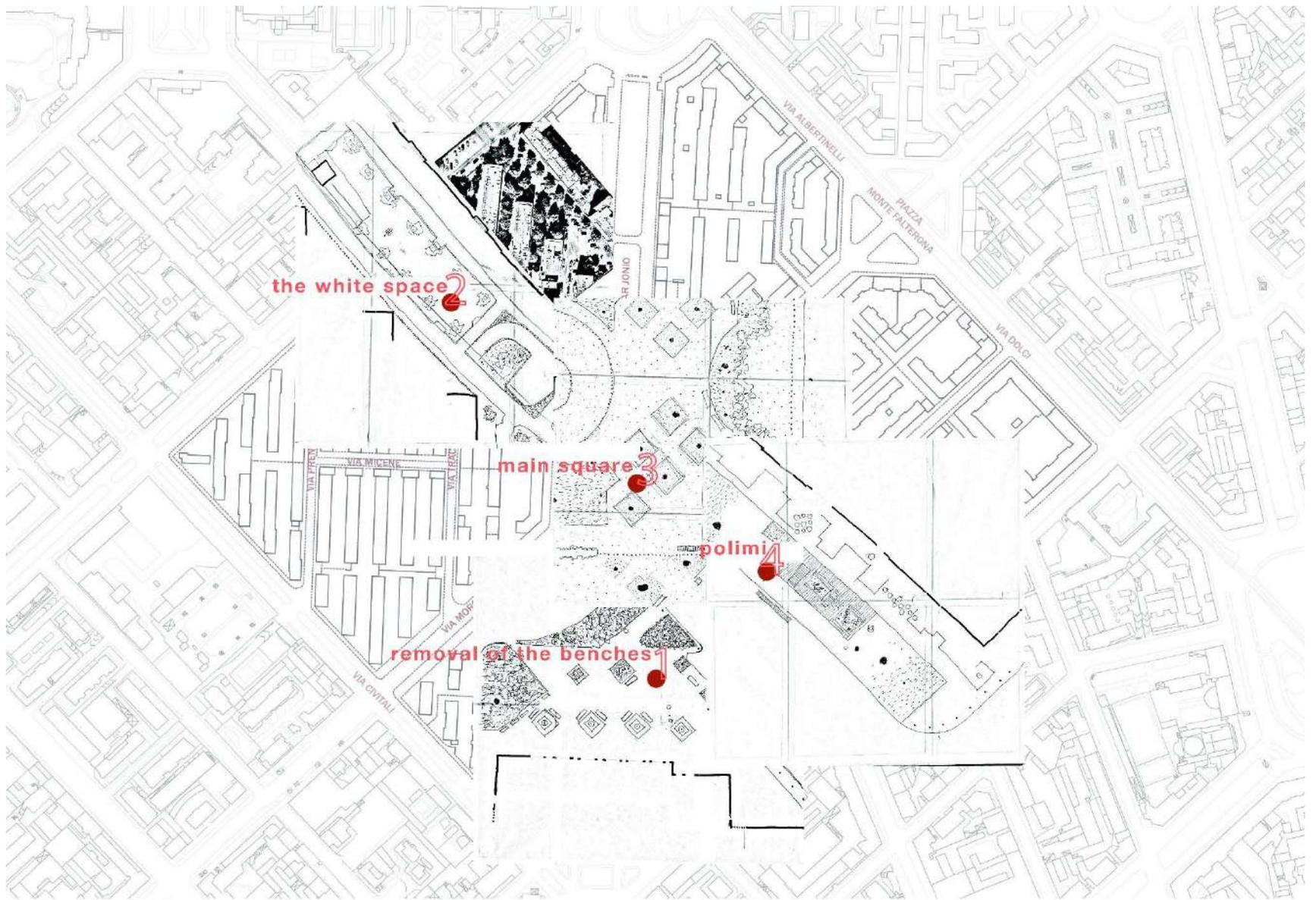

The Map of tour in Final Day

1-Removal of the Benches



2-Main Square



3- White Space

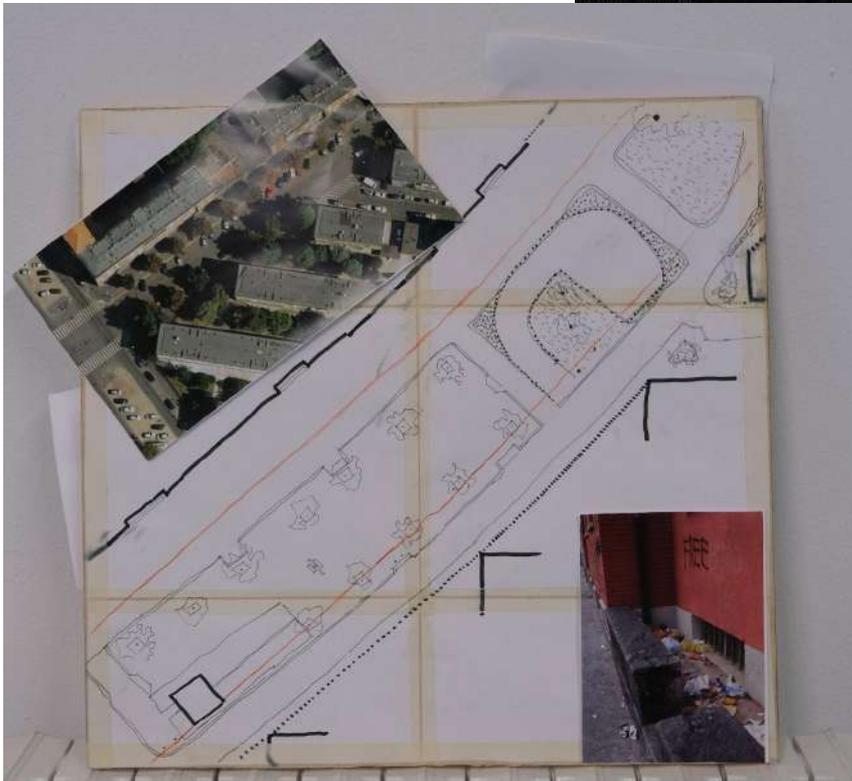

4- Polimi



REFLECTIONS ON RESEARCH PROCESS + OUTPUT

How active/passive was your role in shaping the narrative?

- We have actively shaped the narrative by selecting our interviewees based on common language and positive initial response

Whose perspective is missing? Why?

- The Roma and Italian community are not represented here. This is primarily due to language barrier between our group and them.

How can you check the narrative you have created is accurate and meaningful?

- We feel key findings of our study need to be presented to as much of the community as possible find key issues and to establish active communication about the shared public spaces

Any challenges you faced doing research?

- Language barrier and establishing trust with inhabitants
- Situating individual stories within wider trends without generalizing.

Photo summary

Gioca con noi a Passaparola

1. Pensa e individua un bisogno che senti spesso
2. Scegli il luogo dove trovi l'informazione di cui hai bisogno

Puoi giocare con qualcuno

Passaparola - play with us

1. Think and pick something you often need in San Siro
2. Find where the information is to solve your need

You can play with someone

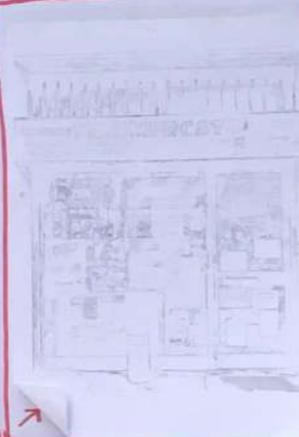
<p>CAF مركز المساعدة الضريبية</p>	<p>MINIMERCATO</p>		<p>HAIRDRESSER ملاق</p>
			



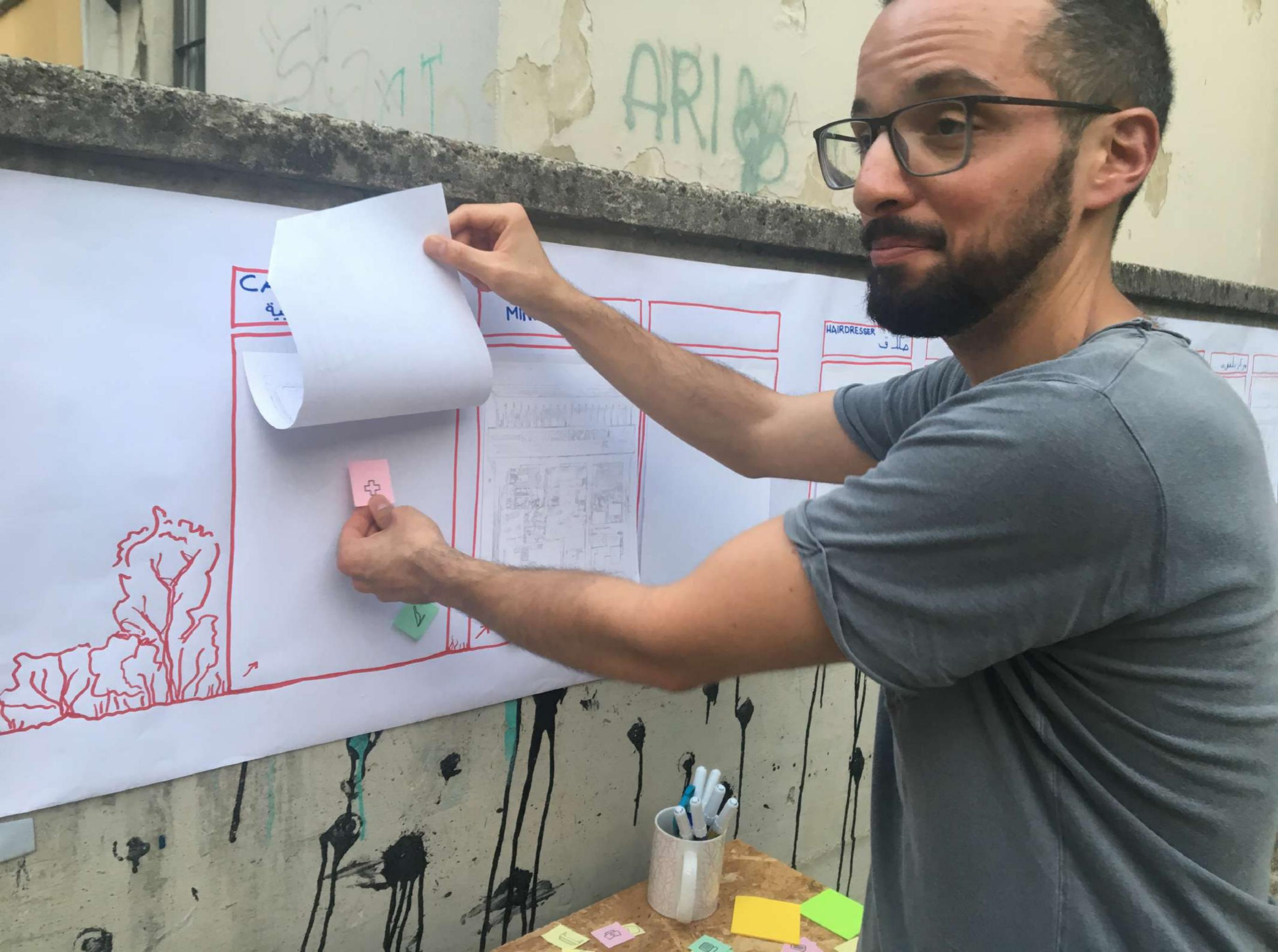

CA
ية

MIN

HAIRDRESSER
ملاق

ملاق





Stories of (ex)change: trajectories in San Siro life and work

The board displays a central map of San Siro with various photos and text cards pinned to it. The cards are color-coded in shades of orange, purple, and teal. The map shows a central area labeled "SAN SIRO" with surrounding areas and a network of lines. The cards contain text and images related to the project, including a section titled "How's change?" and another titled "SAN SIRO".

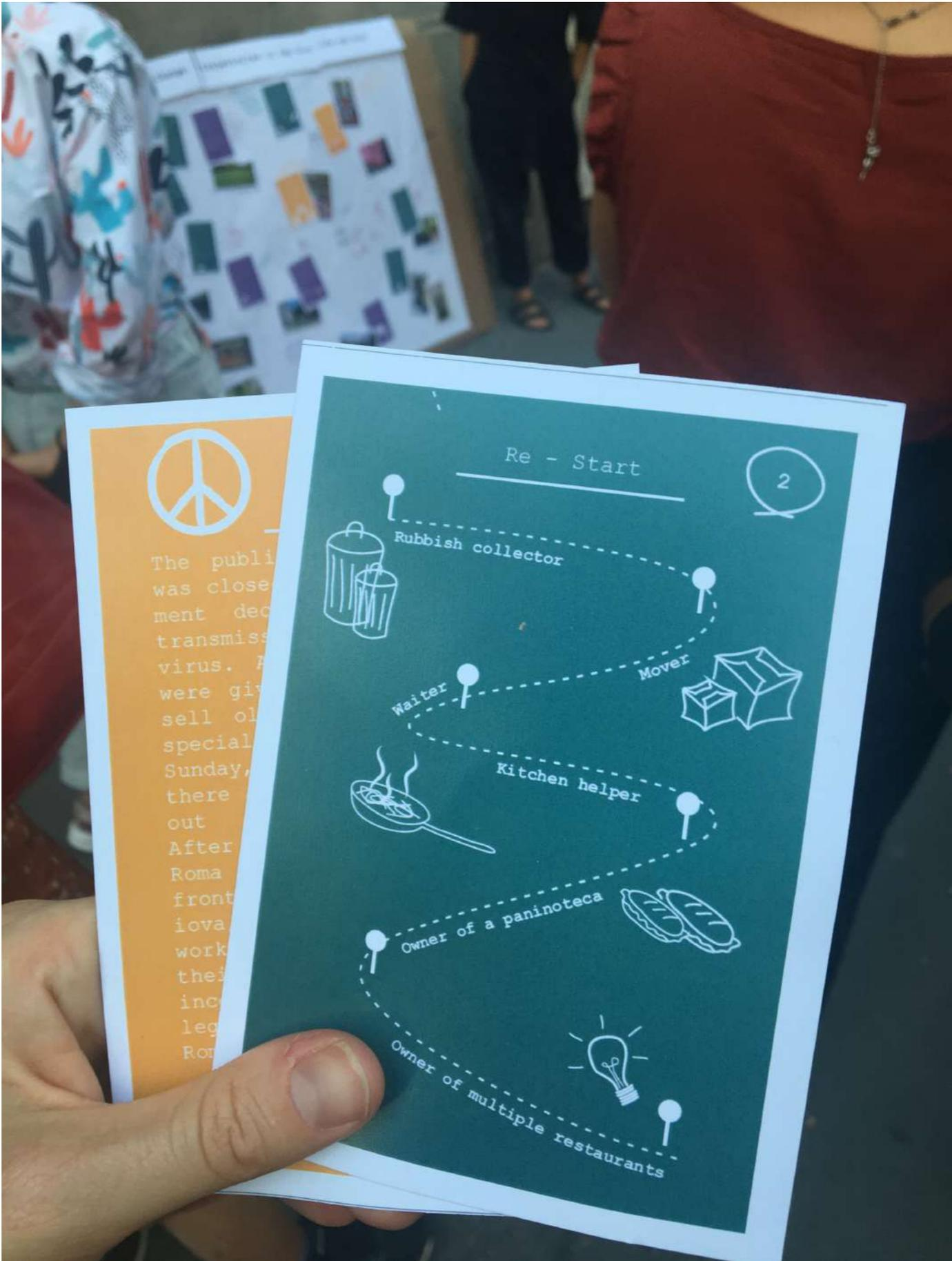



Research Output
Research To
Research Questions
Who did you interact with?
Date of the day
Address
Local Market
Market Day
Date of the day

self-reflection
of our
relationships
times
places
relationships

Paolo
KARSKA
FRITTY

DAY 2: Mapping local actors

EN





Conclusions



The plant is there! In good company too :)

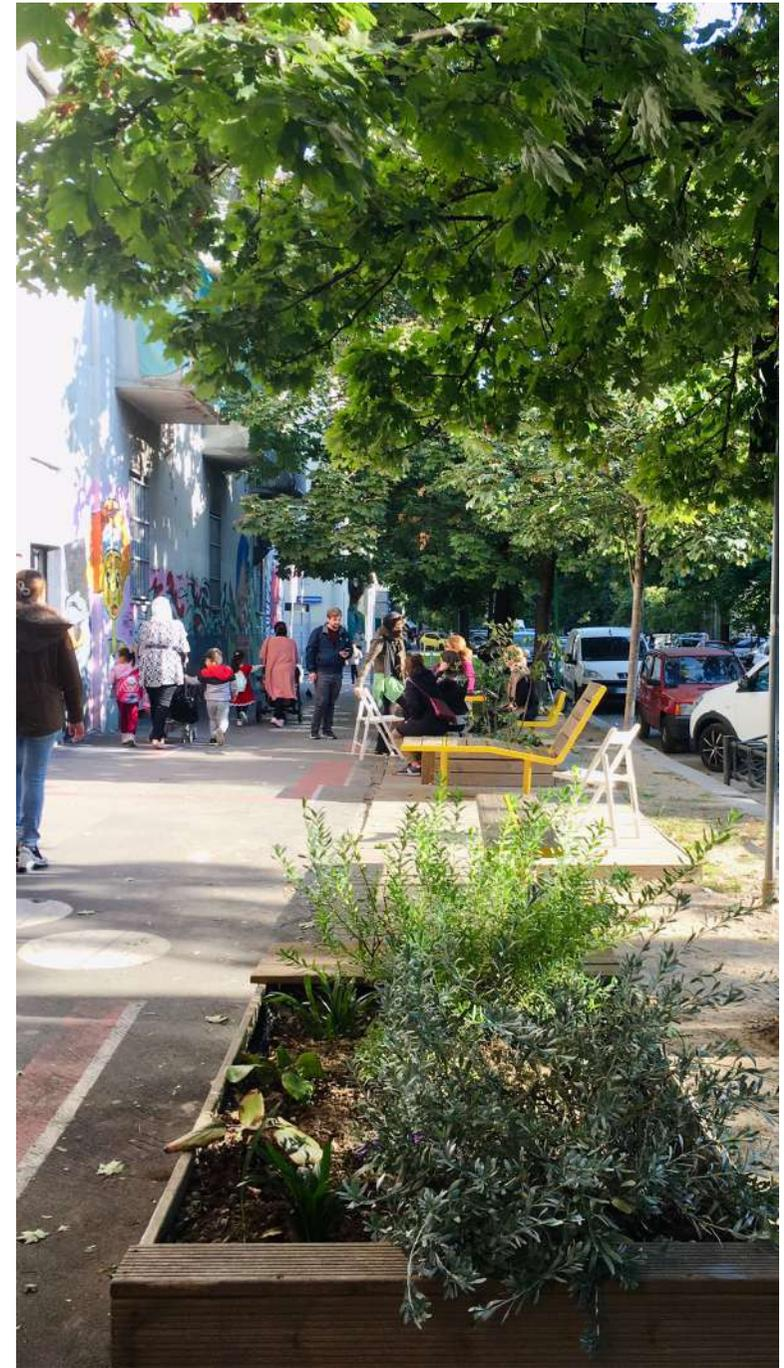



CERTIFICATE OF ATTENDANCE

This is to certify that

[Name, Surname]

Attended the DESINC LIVE: LEARNING IN ACTION - "PRACTICES OF URBAN INCLUSION – COURSE"
BLENDED MOBILITY OF HIGHER EDUCATION STUDENTS AND VET LEARNERS

17 May 2021 – 14 October 2021

Intensive workshops: Berlin, 28 June – 4 July 2021; Milan, 6-12 September 2021

Co-funded by the European Union



National coordinators:

Francesca Cognetti

Beatrice De Carli

Viviana D'Auria

Markus Bader

Rowan Mackay

Giorgio Baracco

Anton Schueneman



Thank you all

Crescere a San Siro. Un'esperienza condivisa. Reportage per immagini e rime

a cura di Rossella Ferro, Niside Panebianco

Questo reportage raccoglie alcune riflessioni sulla quotidianità e i percorsi di crescita dei giovani che abitano nel quartiere di case popolari di San Siro, oltre le narrazioni *mainstream* che spesso catturano e riportano una realtà parziale, o estremizzata, della vita nelle periferie. La recente attenzione mediatica sul fenomeno dei rapper di questa zona è scaturita dall'episodio¹ di scontro con la polizia durante le riprese di un videoclip musicale che attirò 300 giovani da vari quartieri, contravvenendo alle disposizioni anti assembramento che vigevano per via dell'emergenza pandemica. In questa occasione, come in altre, giornali e televisioni si sono limitati a una descrizione aggressiva dei giovani dei quartieri popolari come bande di teppisti che organizzano risse e rapinano i coetanei del centro. Il sospetto che la realtà sia molto più complessa di così ci ha spinte a trascorrere un po' di tempo nel quartiere, guardando alle relazioni tra i giovani e alle loro abitudini con occhi diversi, provando a farci raccontare dai protagonisti qualcosa di sé. Quello che ne abbiamo colto è che, in questo "quartiere della superdiversità"², le traiettorie di vita delle persone non possono essere semplificate. Esistono però alcune costanti (la quotidianità del ritrovo nei cortili, il confronto abituale con situazioni di grave deprivazione economica, il peso dello stigma sociale...) che influenzano fortemente l'esperienza e l'immaginario delle ragazze e dei ragazzi che crescono tra le vie del quadrilatero. Per questo la realtà cantata dal collettivo musicale Seven 700 e altri rapper emergenti, per quanto talvolta evidentemente caricaturale dello stile del "*gangsta rap*", dà voce a sentimenti ed emozioni complicati da definire e da affrontare, dà spazio a voci che altrove non ne hanno. Temi come la ricerca e la costruzione della propria identità, il riconoscersi fra pari,

1 I fatti risalgono al 10 aprile 2021 per le riprese del videoclip di "*Rapina*" - *Baby Gang*" (feat. Neima Ezza), dove sono riportate le immagini degli scontri stessi.

2 Tra le molte variabili di natura sociale, economica, stato legale, a San Siro circa il 55% dei residenti ha origini straniere e frequentemente anche la popolazione italiana ha un background migratorio.

la voglia di riscatto sociale ed economico, scaldano gli animi di migliaia di giovani, anche ben oltre la zona 7 di Milano, ponendosi come un megafono per le istanze di una seconda generazione da un lato totalmente inascoltata e d'altra parte così presente e visibile.

Il reportage è stato realizzato nell'ambito della sperimentazione di DesInc Live³, un corso semestrale organizzato a cavallo tra quattro università (PoliMi, London Met, KU Leuven, UdK Berlin) e organizzazioni della società civile (Architecture sans Frontières UK, Refugees Welcome Italia, S27 Kunst und Bildung). Il corso, volto a sperimentare attivamente pratiche per la città inclusiva, ha previsto diverse tappe online ed in presenza, tra cui un workshop intensivo di una settimana a San Siro nel settembre 2021 dove si sono incontrati studenti, attivisti, docenti e tutor con l'obiettivo di costruire nuove narrazioni sul quartiere e per il quartiere. Da questa esperienza formativa è nata una collaborazione tra le autrici del reportage che, senza avere troppo chiari la forma e i contenuti dell'*output* che questa piccola ricerca avrebbe prodotto, hanno continuato l'esplorazione del quartiere attraverso la pratica della fotografia documentaria e situata. Stare, immergersi nel quartiere, è stato l'inesco di questo lavoro, insieme all'incontro e al coinvolgimento di alcuni giovani abitanti: sono state consegnate loro delle macchine fotografiche usa e getta, chiedendogli di scattare alcune foto. Raccoglierne l'esito è stato più complicato del previsto, perciò questo contributo è solo parzialmente qui incluso, ma ha rappresentato un momento di contatto che ha permesso di elaborare alcune riflessioni importanti. Infine, muovendosi nel quartiere, tra le sue storie, navigando online tra i tanti brani e videoclip musicali, leggendo notizie, sono state raccolte moltissime informazioni che si sono fuse ad impressioni, emozioni, idee personali delle autrici. Per riorganizzare la mole di immagini e pensieri, l'*Atlante del Cambiamento*⁴ elaborato da Dynamoscopia è stata una fondamentale fonte d'ispirazione, insieme al confronto costante con le ricercatrici e i ricercatori di Mapping San Siro, un laboratorio di ricerca promosso dal Politecnico di Milano, con sede nel quartiere San Siro.

3 Il sito web del corso: <https://www.desinclive.eu/>

4 Ass. cult. Dynamoscopia, a cura di, (2018). *Atlante del cambiamento. E 31 domande per interrogarlo*. Milano: Dynamoscopia

This reportage collects some reflections on the everyday life and growth paths of young people living in social housing buildings in the neighbourhood of San Siro, and aims to question the mainstream narratives that often capture and report a partial, or extreme, reality of life in the suburbs. The recent mediatic attention on the phenomenon of rappers in this area was triggered by the episode⁵ of a clash with the police during the production of a music video that attracted 300 young people from different neighbourhoods, in contravention of the anti-gathering regulations in force due to the pandemic emergency. On this and other occasions, newspapers and tv stations' reports were limited to aggressive depictions of the youth from working-class neighbourhoods as gangs of thugs putting up fights and robbing their peers from the city centre. The suspicion that reality is much more complex than this led us to spend some time in the neighbourhood, looking at young people's habits and relationships with different eyes and trying to involve them in the narration of their stories. What we learnt from this is that, in this "neighbourhood of superdiversity"⁶, people's life trajectories cannot be generalized. Nevertheless, there are certain constants (the daily meetups in the courtyards, the habitual confrontation with serious economic deprivation, the weight of social stigma...) that strongly influence the experience and imagery of the youngsters growing up in the streets of the district. This is why the reality sung by the Seven 700 music collective and other emerging rappers – although sometimes clearly caricatured in the style of "gangsta rap" – contains feelings and emotions that are hard to define and deal with, and gives space to voices that do not have any elsewhere. Topics such as the quest and construction of one's own identity, the recognition among the peers, the pursuit of social and economic redemption, warm the hearts of thousands of young people, even well beyond Milan's zone 7, acting as a megaphone for the demands of a second generation of immigrants, often totally unheard and yet so present and visible.

⁵ Facts date back to April 2021, the 10th, during the shooting for the music video of "Rapina" - Baby Gang (feat. Neima Ezza), which shows the images of the clashes.

⁶ Among the many variables of social and economic nature, or legal status, in San Siro district about 55% of the residents have foreign origins and frequently also the Italian population has a migratory background.

The reportage was produced as part of the experimentation of DesInc Live⁷, a six-month course organised between four universities (PoliMi, London Met, KU Leuven, UdK Berlin) and civil society organisations (Architecture sans Frontières UK, Refugees Welcome Italia, S27 Kunst und Bildung). The course, aimed at actively experimenting practices for inclusive cities, consisted of several stages, both online and in-presence, including a week-long intensive workshop that took place in San Siro in September 2021. Students, activists, teachers and tutors met with the aim of building new narratives of and for the neighbourhood. From this formative experience was born a collaboration between the authors of the reportage who – without having too clear the form and content of the output that this small research would lead to – continued to explore the neighbourhood through documentary and situated photography. The act of staying and immersing ourselves in the neighbourhood allowed this work to sprout, together with the involvement and guide of some young inhabitants that were given disposable cameras and asked to take some photos. Collecting the results was more complicated than expected, reason why this contribution is only partially included here, but it represented a moment of contact that allowed us to elaborate some important reflections. Moving around the neighbourhood and discovering its stories, listening to many songs and watching their music videos online, reading news, a great deal of information was collected, which merged with the impressions, emotions and personal ideas of the authors. In order to reorganise the mass of images and thoughts, the "*Atlante del Cambiamento*"⁸ elaborated by Dynamoscopia was a fundamental source of inspiration, together with the constant comparison with the researchers of *Mapping San Siro*, a research laboratory promoted by the Milan Polytechnic, based in San Siro neighborhood.

7 The website of the course: <https://www.desinclive.eu/>

8 Ass. cult. Dynamoscopia, edited by, (2018). *Atlante del cambiamento*. E 31 domande per interrogarlo. Milano: Dynamoscopia

Come si riflette la periferia negli occhi dei giovani che la abitano?

San Siro è un quartiere popolare ormai al centro della città: adiacente a due linee della metropolitana, nel mezzo di grandi operazioni di trasformazione urbana. Abbiamo affidato ad Abdel e Chaima, entrambi diciottenni, una macchina fotografica usa e getta chiedendo loro di scattare alcune foto, domandandogli dove si sentissero a casa e cosa caratterizzasse il quartiere.

 Non giocare con noi / Abbiamo il quartiere dietro / Dentro la torre di Selinunte diventerà un grattacielo / Rolls Royce come a Manhattan / San Siro Gotham City senza Batman (haram)

SEVEN 700 - Rondo, Neima Ezza, Sacky, Keta, Kilimoney, Vale Pain

Abdel ha fotografato il quartiere guardandolo dall'alto. Ha scelto come luogo d'osservazione il parco urbano della Montagnetta di San Siro, un rilievo artificiale costruito con le macerie della seconda guerra mondiale. Sulla sinistra si riconosce il profilo dello stadio Meazza, sul cui futuro è acceso un dibattito cittadino di opinioni contrastanti.

[ph Abdel Rahman]



Chaima ha fotografato il quartiere guardandolo da dentro. La foto ritrae il parcheggio di via Aretusa, dove spesso sostano roulotte e case mobili.

[ph Chaima Hichri]

Da dove nasce l'orgoglio di venire dal niente?

La cultura trap e drill sta in qualche misura contribuendo ad accendere un riflettore sulle condizioni socio-economiche dei quartieri popolari. Nuove *crew* si moltiplicano a Milano da via Padova a Rozzano, così come nei quartieri ex IACP e Gescal di centri minori lungo tutta la penisola. Videoclip musicali ne esaltano le architetture razionaliste, con citazioni continue di toponimi e *landmark* comprensibili solo a chi vive quotidianamente il "blocco". Le rime ostentano un senso di appartenenza a questi contesti denunciando esplicitamente le condizioni di estrema povertà e marginalizzazione. Piovono milioni di *views* e ascolti, e arrivano diversi dischi d'oro. Per chi è questa musica e cosa significa per chi la produce e per chi la riproduce?

 Mi ricordo che non c'era niente dentro al piatto / La situazione lo sai che non è cambiata affatto / Sono povero e me ne vanto perché della vita non ho avuto un cazzo

Leggenda - Rondo da Sosa

Il muretto all'interno del cortile di via Abbiati 6 appare a volte nelle *stories* sui social dei rapper del quartiere.
[ph Niside Panebianco]



La ripetitività e la monotonia dei moduli architettonici delle case popolari assumono un fascino ritmico nei videoclip.
[ph Niside Panebianco]

Quali assetti si generano dalla relazione con uno spazio "rotto"?

Il posizionamento spaziale di questo fenomeno culturale e discografico, profondamente radicato negli ambienti pubblici e semipubblici delle case popolari, è una delle costanti che accomuna la stragrande maggioranza delle *crew*. Camminando per San Siro, addentrandosi tra i caseggiati, alcune immagini si ripetono nella realtà così come inscenato nei videoclip. In particolare, emergono l'uso e la condivisione durante l'infanzia e la prima adolescenza degli spazi del gioco: i cortili interni malconci, i marciapiedi dove si accumula la spazzatura, ma anche *location* avventurose come i tetti, le cantine dove a volte dormono i senzateetto, gli stabili abbandonati e fatiscenti dei servizi pubblici dismessi. Luoghi non neutri che segnano l'esperienza della crescita. Che forma prende e cosa si imprime nella coscienza in costruzione dei giovani abitanti?

 Vengo dalla perif / Bilocale, ma non è una casa, vengo dalla perif / Viviamo in cinque in una stanza di 40 metri / Qui siamo buttati per strada da quando sono baby

Perif - Neima Ezza

Il piccolo taglio degli appartamenti Aler talvolta spinge i bambini e le bambine di famiglie numerose o con case affollate a cercare all'esterno dell'abitazione i propri spazi, anche quelli più tradizionalmente legati all'intimità della casa, come ad esempio spazi di privacy, quiete e concentrazione (nella foto, qualcuno fa i compiti sulle scale)
[ph Niside Panebianco]



Il cortile di via Zamagna, luogo principe delle ambientazioni del collettivo musicale *Seven 700*.
[ph. Niside Panebianco]



Tre ragazzi si atteggiano con bici e bandane, sullo sfondo una casa andata a fuoco recentemente.
[ph. Niside Panebianco]

Il cortile di Chaima.
[ph Chaima Hichri]



Il cortile di Abdel.
[ph Abdel Rahman]

In quante rappresentazioni diverse si riconoscono i giovani di San Siro?

Le tematiche ricorrenti della musica prodotta in quartiere riguardano spesso i soldi, la droga, episodi di microcriminalità, spaccio, rapine, armi, risse. La rappresentazione mediatica *mainstream* si concentra su questi aspetti che indubbiamente permeano molti brani, e hanno talvolta un grado variabile di correlazione con episodi accaduti, ma esiste una discrasia tra realtà e autorappresentazione? Questa ipotesi risulta tanto più evidente analizzando la figura femminile⁹ che emerge dalle canzoni: le ragazze che si incrociano per le strade del quartiere appaiono molto distanti dalla donna oggetto del desiderio sessuale che viene descritta generalmente nelle rime e nei videoclip. È possibile racchiudere sotto la stessa etichetta tutti i giovani di San Siro appiattendone ogni sfumatura e differenza?

 Lacrim è come Savastano / Sacky e Baby come Gennaro e Ciro¹⁰
Gennaro & Ciro - Sacky (feat. Lacrim, Baby Gang)

⁹ Un discorso diverso vale per la figura della madre, in un'alternanza stridente di narrazioni della donna contrastanti ed estremizzate.

¹⁰ Un riferimento ai personaggi della serie *Gomorra* (tratta dagli omonimi libro e film), che racconta le guerre tra clan a Napoli.

Una ragazza si affretta verso l'ingresso della sua scala.
[ph Niside Panebianco]



Madre e figlia si recano a fare spese.
[ph Niside Panebianco]

Esistono delle rivendicazioni latenti dietro alle rime in stile *gangsta*?

Altri argomenti si manifestano con potenza nelle canzoni, tra gli altri l'esperienza della comunità o del carcere minorile che arrivano all'apice di un susseguirsi di situazioni familiari complicate, di deprivazione materiale, in seguito all'abbandono scolastico, o per reati minori: si attiva un *loop* da cui è difficile riemergere. Chiedendo giustizia per il loro amico Anas, detenuto al Beccaria, i rapper scrivono che è «vittima di un sistema sbagliato e irresponsabile nei confronti dei giovani». Per Anas è anche comparsa una grande scritta a led in uno spazio pubblicitario di Piazzale Cadorna. Questo senso di persecuzione e ingiustizia che i rapper della *Seven 700* esprimono nei brani musicali viene in parte da loro stessi messo in relazione al background migratorio delle proprie famiglie. L'essere «straniero» è dall'altro lato motivo di orgoglio: si enfatizza il bilinguismo e i riferimenti alla cultura araba e sudamericana sono continui, tracciando un *parterre* comune che rafforza i legami interni al quartiere e con chi ha vissuto o è stato vicino ad esperienze simili.

 Alo, Baby sangue arabo, Baby Ganga di Casablanca / Khouya 7areg mechi l Milano nriski dammi 3arbi ya, mamma¹¹ / "Chi va piano, non va lontano", mi diceva sempre Abdallah / Sogna passaporto italiano, Baby fuma, fa zanga zanga / E fa zanga zanga, moroccan son di Casablanca / Bambini in barca a Tangia¹² sognan di arrivare in Spagna / 3arbi in Italia, trabaja solo con la baida¹³ / Su un mezzo, fra', senza la targa
Casablanca - Baby Gang (feat. Morad)

11 «Fratello, ho bruciato la frontiera per andare a Milano, ho rischiato il sangue arabo, mamma».

12 Tangeri, la città portuale del Marocco sullo Stretto di Gibilterra.

13 «Arabo in Italia, lavoro solo con la cocaina» (*baida* è bianco in lingua araba).

È frequente incontrare nei bar giovani migranti neo arrivati in attesa di una chiamata di lavoro.

[ph Niside Panebianco]



Il parco giochi di Piazza Selinunte è una palestra di meticcio a cielo aperto.
[ph Niside Panebianco]

Una bambina e un bambino si nascondono in un cortile.
[ph Niside Panebianco]



La sorella di Abdel e una sua amica giocano in casa.
[ph Abdel Rahman]

Qual è la potenza collettiva di un sogno personale di riscatto?

Infine, il sodalizio fra i ragazzi del "blocco" per un futuro migliore per tutti i "fratelli" è un messaggio che passa frequentemente tra le rime e che esplicita una dimensione collettiva del successo individuale. A chiusura del lavoro, molte domande restano aperte. Ci chiediamo, ad esempio, in termini di redistribuzione economica - tramite incarichi speciali, partecipazioni ai videoclip e alle produzioni - quante famiglie di San Siro beneficino diffusamente del successo dei ragazzi ventenni del collettivo Seven 700. In generale, che influenza ha il loro successo sui coetanei del quartiere? E soprattutto, l'immaginario di riscatto che i ragazzi del collettivo incarnano può favorire la costruzione di orizzonti di possibilità ed emancipazione per i giovani delle periferie?

 Quattordici anni estate in città / No lamenti perchè / Sono tranquillo / So che dio c'ha un piano grosso per me

RM4E Freestyle - Vale Pain 

[ph Niside Panebianco]



[ph Niside Panebianco]

♯🎵 Più sei famoso e più sei solo / Cambiare me stesso non è quel
che voglio / Finché avrò i miei fratelli rinchiusi lì¹⁴/ Fare sti soldi lo sai
che non mi renderà felice

Alone/Solo - Rondo da Sosa

¹⁴ Rinchiusi nel blocco, il quartiere popolare di San Siro.

[ph Niside Panebianco]

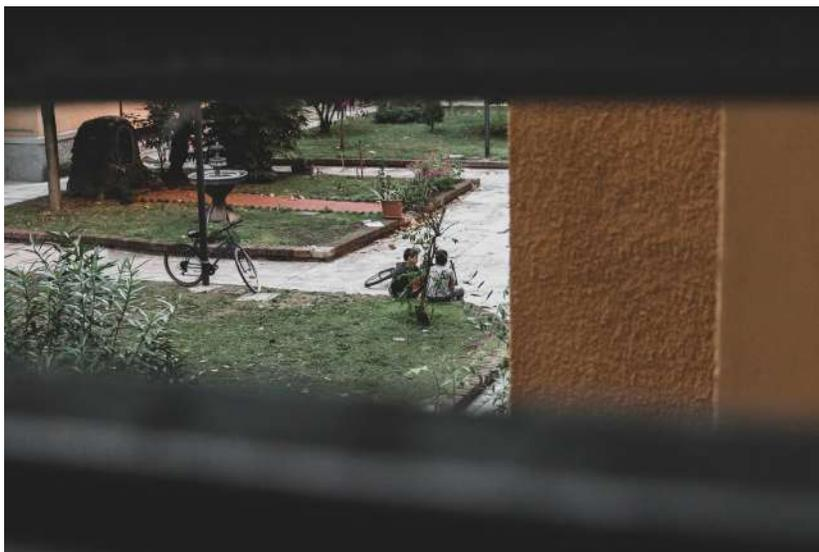

[ph. Niside Panebianco]

♯🎵 Siamo partiti dal niente, da meno zero / Tu mi conosci da sempre,
da quanto, lo spero / Se senti lo sparo, corri al riparo, mi guardi le
spalle / Io te le guardo, pusher e ladro / Taglio il traguardo soltanto
con te

Frero - Neima Ezza



[ph Rossella Ferro]

Rossella Ferro è una ricercatrice urbana con un *background* di attivismo nei movimenti sociali e di lotta per la casa. Coordinatrice di progetti di educazione non formale e di scambi interculturali per i giovani. Co-fondatrice di Frange Mobili, collettivo interdisciplinare per l'architettura inclusiva e la rigenerazione territoriale, che sviluppa progetti abitativi rivolti a popolazioni fragili e iniziative culturali in contesti di marginalità spaziale. Al momento è coinvolta in un progetto di ricerca e accompagnamento ad alcune amministrazioni dell'hinterland di Milano sulle politiche per la casa e di contrasto all'emergenza abitativa. rossella.ferro@mail.polimi.it

Niside Panebianco è una fotografa documentarista itinerante tra Portogallo e Italia. Il suo lavoro esplora i temi della migrazione e dell'identità a partire da luoghi e storie periferiche. L'osservazione delle trasformazioni sociali di alcune comunità nomadi Amazigh nel deserto del Sahara l'ha portata a ricercare le conseguenze dell'urbanizzazione di massa sulle comunità che abitano ai margini. Da questa esperienza è nata una riflessione sulla fragilità dei territori del meridione italiano, dalla quale proviene. Il lavoro *An Essential Condition*, con cui ha conseguito la laurea in fotografia alla London Metropolitan University, tratta il tema delle "città doppie" calabresi nella prospettiva dell'antropologia del paesaggio. niside.ph@gmail.com